

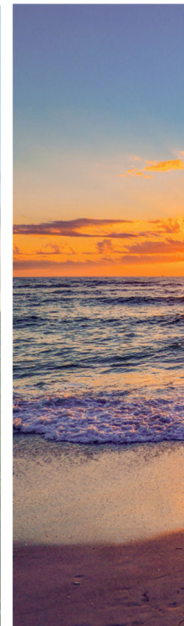

# STORMWATER MANUAL

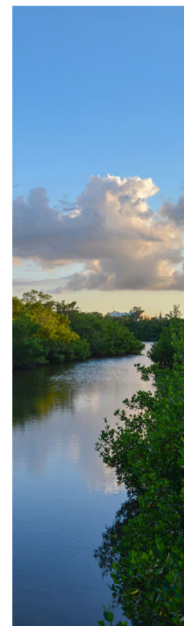



## **SARASOTA COUNTY STORMWATER MANUAL**

**Prepared for:**

Sarasota County  
Public Works/Stormwater  
1001 Sarasota Center Blvd.  
Sarasota, FL 34240

**Prepared by:**

Jones Edmunds & Associates, Inc.  
7230 Kyle Court  
Sarasota, Florida 34240

Certificate of Professional Engineering Authorization #1841  
Jones Edmunds Project No.: 19006-066-01

Updated June 2024

# TABLE OF CONTENTS

## CHAPTER 1 – LAND DEVELOPMENT REVIEW

<b>1</b>	<b>INTRODUCTION.....</b>	<b>1-1</b>
1.1	Purpose.....	1-1
1.2	Community Need.....	1-2
1.3	Quick User Guide.....	1-2
1.4	Contact Information and File Retrieval Location.....	1-3
<b>2</b>	<b>SUBMITTAL REVIEW PROCEDURES.....</b>	<b>2-1</b>
2.1	Site Development and Subdivision Submittal.....	2-1
2.2	Final Subdivision Plat Submittal.....	2-2
2.3	Earthmoving Permit Submittal.....	2-3
2.4	Submittal Requirements for Stormwater Division Reviews.....	2-4

## CHAPTER 2 – STORMWATER DIVISION REQUIREMENTS

<b>3</b>	<b>STORMWATER DESIGN AND ANALYSIS CRITERIA.....</b>	<b>3-1</b>
3.1	Comparison of County and SWFWMD Criteria.....	3-1
3.2	Stormwater Design.....	3-2
3.3	Stormwater Attenuation and Flood Control.....	3-3
3.4	Stormwater Treatment.....	3-5
3.5	Development within a Flood Zone.....	3-7
3.6	Revised Existing Conditions.....	3-8
3.7	Master Stormwater Management Systems.....	3-9
3.8	Request for Variance from Stormwater Criteria.....	3-10
<b>4</b>	<b>DATA DELIVERY STANDARDS.....</b>	<b>4-1</b>
4.1	Drawings.....	4-1
4.2	Maps.....	4-2
4.3	Supporting Calculations.....	4-3
4.4	Stormwater Model Data.....	4-4
4.5	Model-Related Spatial Data.....	4-4

## CHAPTER 3 – TECHNICAL GUIDANCE

<b>5</b>	<b>RATIONAL METHOD.....</b>	<b>5-1</b>
5.1	Design Approach Description.....	5-1
5.2	Determining Peak Runoff Rate.....	5-4

5.3	Sizing Stormwater Conveyance Features.....	5-6
5.4	Sizing Attenuation Ponds.....	5-7
5.5	Approach Specific Submittal Requirements.....	5-8
<b>6</b>	<b>HYDROGRAPH METHOD .....</b>	<b>6-1</b>
6.1	Design Approach Description.....	6-1
6.2	Model Development.....	6-5
6.3	Hydrologic Parameters .....	6-6
6.4	Hydraulic Parameters .....	6-8
6.5	Boundary Conditions .....	6-14
6.6	Simulation Manager.....	6-15
6.7	Quality Control .....	6-16
6.8	Approach-Specific Submittal Requirements .....	6-17
<b>7</b>	<b>MODEL INCORPORATION METHOD .....</b>	<b>7-1</b>
7.1	Design Approach Description.....	7-1
7.2	Model Development.....	7-6
7.3	Hydrologic Parameters .....	7-7
7.4	Hydraulic Parameters .....	7-9
7.5	Boundary Conditions .....	7-14
7.6	Simulation Manager.....	7-14
7.7	Quality Control .....	7-16
7.8	Approach-Specific Submittal Requirements .....	7-16
<b>8</b>	<b>SUPPLEMENTAL TECHNICAL GUIDANCE.....</b>	<b>8-1</b>
8.1	ICPR4 Quality Control Recommendations .....	8-1
8.2	ICPR4 Scenarios .....	8-3
8.3	Secondary Stormwater Management System Calculations.....	8-4
8.4	Bridge Modeling .....	8-4
8.5	Drawdown Calculations Using Percolation Links.....	8-5
8.6	Two-dimensional Surface Routing .....	8-5
8.7	Low-Impact Development and Green Infrastructure.....	8-5
8.8	ICPR3 Migration to ICPR4 .....	8-6
 <b>CHAPTER 4 – REFERENCES AND ATTACHMENTS</b>		
<b>9</b>	<b>REFERENCES .....</b>	<b>9-1</b>
<b>Attachment 1</b>	Earthmoving Permit Application Form	
<b>Attachment 2</b>	UDC Article 18 Appendices: Stormwater Review Checklists and Summary Forms	

- Attachment 3** UDC Article 18 Appendices: Stormwater Design Criteria
- Attachment 4** Cup-for-Cup Floodplain Compensation Example Graphic
- Attachment 5** Submittal Data Key Sheet
- Attachment 6** Time of Concentration Template
- Attachment 7** FDOT Zone 6 100-Year IDF Curve and Development of County Regression Equation
- Attachment 8** Example Level of Service Summary with Internal Pipe Calculations
- Attachment 9** Pond Storage Volume Design Template for the Rational Method
- Attachment 10** 2005 Sarasota County Watersheds Floodplain Model Methodology Report
- Attachment 11** Unit Hydrographs
- Attachment 12** ICPR4 Input Data Comparator Documentation
- Attachment 13** ICPR4 Input Data QC Tool Documentation
- Attachment 14** Outline of Sarasota County ICPR3 to ICPR4 Conversion Requirements

## LIST OF TABLES

Table 1.1	Summary of Hydrologic Design Methods.....	1-3
Table 3.1	Summary of Additional Stormwater Design Criteria .....	3-1
Table 3.2	Approved Hydrologic Design Method Use by Project Characteristics .....	3-4
Table 3.3	Allowable Flood Depth by Design Storm Return Period .....	3-5
Table 4.1	Map Legend Format Requirements.....	4-3
Table 4.2	Summary of Feature Data Requirements .....	4-5
Table 5.1	Summary of Recommended Runoff Coefficients .....	5-5
Table 6.1	Suggested Overland Flow Geometry .....	6-14

## LIST OF FIGURES

Figure 4.1	Example ICPR4 Package Folder Structure .....	4-4
Figure 6.1	ICPR4 Simple Basin Data GUI .....	6-6
Figure 6.2	ICPR4 Link Pipe Data GUI .....	6-9
Figure 6.3	ICPR4 Link Channel Data GUI .....	6-11
Figure 6.4	ICPR4 Node Data GUI.....	6-13
Figure 6.5	ICPR4 Link Weir Data GUI .....	6-14
Figure 6.6	ICPR4 Simulation Manager GUI.....	6-16
Figure 7.1	Watersheds for County Basin Models .....	7-3
Figure 7.2	ICPR4 Simple Basin Data GUI .....	7-7
Figure 7.3	ICPR4 Link Pipe Data GUI .....	7-10
Figure 7.4	ICPR4 Link Channel Data GUI .....	7-11
Figure 7.5	ICPR4 Node Data GUI.....	7-13
Figure 7.6	ICPR4 Link Weir Data GUI .....	7-14
Figure 7.7	ICPR4 Simulation Manager GUI.....	7-16
Figure 8.1	Example ICPR3-to-ICPR4 Log File.....	8-7
Figure 8.2	Example ICPR4 Cross-Section with Bottom and Top .....	8-9

## VERSION HISTORY

September 2020: Draft Manual submitted to Stormwater Division for review.

March 2021: Revised Manual submitted to Stormwater Division for review.

August 2021: Final Manual submitted to Stormwater Division, based on 2021 codes.

July 2022: Manual revised to include new ICPR4 Tool documentation, model link solution approaches, and other minor corrections.

June 2024: revised to reflect Unified Development Code updates made in 2023 that regulates to three design storms and clarifies side lot easement reduction requirements.

## PREFACE

While the Sarasota County Stormwater Division is only a part of County’s land development review process, Stormwater Division staff is committed to providing fair and expedient reviews of stormwater submittals. The primary intent of this manual is to facilitate the stormwater review process. Review criteria and procedures presented in this manual are dictated by the Sarasota County Code. Technical guidance has been jointly developed by Jones Edmunds & Associates, Inc. and the Stormwater Division based on standard engineering practice and well-accepted community standards.

The breadth of potential material to be covered within this manual is nearly infinite. Since the intent is to facilitate the stormwater review process, focus throughout is given to common situations that would be most applicable to land development projects within Sarasota County. To that end, the manual has been organized to walk users through the stormwater review process, by explaining the procedural steps, presenting the relevant stormwater criteria, and providing technical guidance commonly necessary to develop a Stormwater Master Plan and relevant supporting materials that meet County approval standards.

This manual was developed by Jones Edmunds on behalf of the Stormwater Division. This manual is best viewed as a continuation of the standard that has been established through past collaborative efforts between the County, engineering consultants, and development community.

## GLOSSARY

Stormwater Methodology Meeting	The meeting is expected to cover hydrologic design approach, design criteria, updates from past submittals, submittal guidance, available data, and data that is anticipated to become available during project development. This meeting is separate from the pre-submittal conference with the Development Review Coordination (DRC) committee and should be scheduled directly with the Stormwater Division.
DRC Pre-submittal Conference	The pre-submittal conference with the DRC committee is not a stormwater-focused meeting. The Stormwater Division attends this meeting and may provide guidance to the applicant during the meeting; however, typically limited information is known about the land development project at the time of this conference. Stormwater-related guidance is best provided in a separate Stormwater Methodology Meeting.
Subdivision of Land	The division or platting of real property into three or more lots or parcels, including resubdivision or establishment of streets or alleys.
Land Development	A subdivision of land or a site improvement such as construction, reconstruction, demolition conversion, structural alteration, relocation, or enlargement of any structure, whether residential, commercial, industrial, office, professional, institution, or recreational. This term also includes any excavation, landfill, or land disturbance and any use or extension of the use of land.
Stormwater Management System	The appurtenances, facilities, and designed features of the property that collect, convey, channel, hold, treat, detain, or divert stormwater runoff. These systems may include low-impact development techniques.
Capital Improvement	A project designed to improve public facilities including but not limited to transportation, sanitary sewer, solid waste, drainage, potable water, educational, parks and recreational, and health systems.
Applicant	The land development project owner or owner's representative.
Engineer of Record	A professional engineer licensed by the State of Florida who sealed drawings, reports, and/or documents for a project application. By seal, the professional engineer acknowledges they have coordinated, prepared, or had subordinates prepare under their direct supervision all relevant drawings, reports, and/or documents for the application.
Basin Model	The County has developed stormwater models for several watersheds. In the <i>Unified Development Code</i> (UDC) and this Manual, these models are referred to as Basin Models.
Existing Condition	The drainage condition of the project site before activities related to land development that is part of the subject submittal.
Proposed Condition	The drainage condition of the project site after activities related to land development that is part of the subject submittal have been completely constructed.

# CHAPTER 1

## LAND DEVELOPMENT REVIEW

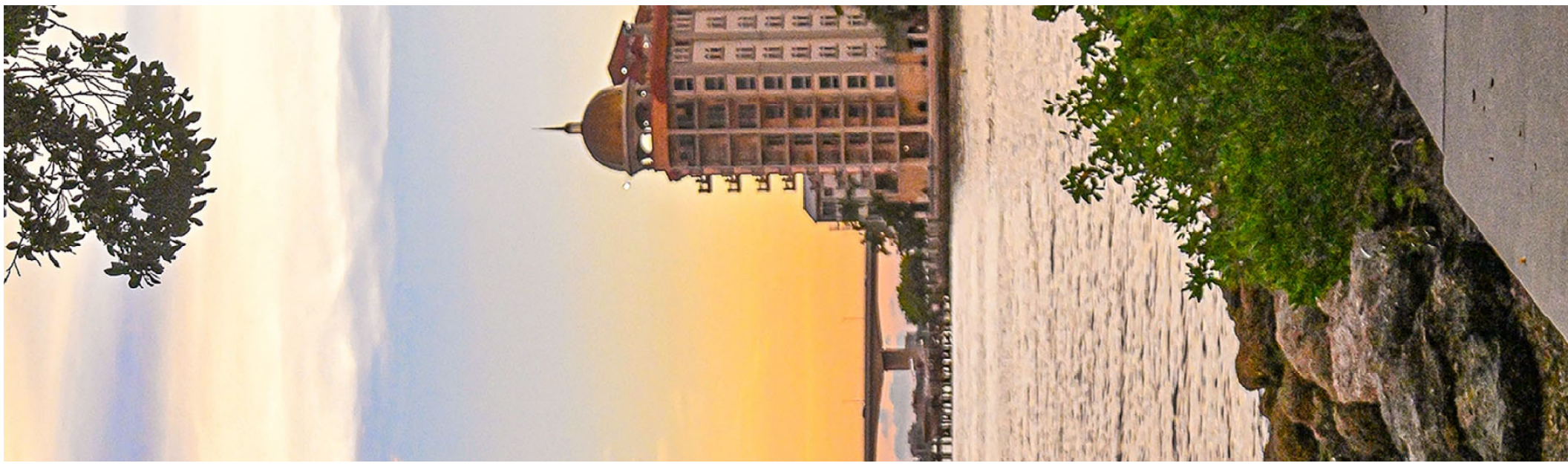



# 1 INTRODUCTION

Sarasota County regulates land development through the County's *Unified Development Code* (UDC), and is included as Chapter 124 of the Sarasota County Code. The Stormwater Division participates in the County's land development process primarily by providing stormwater reviews of proposed Site Development, Subdivision, and Capital Improvement projects. This 2020 version of the Sarasota County Stormwater Manual is focused on procedural and technical guidance for these stormwater reviews. The Stormwater Division also provides stormwater reviews of Earthmoving permits and Final Subdivision Plat submittals. Additional procedural guidance for these reviews is provided in this Manual. This Manual supersedes the 2007 Sarasota County Stormwater Manual.

This Manual also includes technical guidance related to County stormwater standards and specifically to the latest generation of Streamline Technologies, Inc.'s Interconnected Channel and Pond Routing Model (ICPR) Version 4, aka ICPR4, that was released in 2014 and is a well-accepted stormwater modeling software platform in southwest Florida. ICPR4 replaces ICPR Version 3, which Streamline Technologies stopped supporting in 2016. In 2024, Streamline Technologies changed the name of ICPR to StormWise. The names ICPR4 and StormWise in this manual mean the same thing and shall reflect the latest version of the county basin models.

## 1.1 PURPOSE

The Sarasota County Stormwater Manual is intended to guide County staff and the local development community toward meeting County stormwater design, stormwater analysis, and development review requirements for land development projects, earthmoving permits, and plat submittals in Sarasota County. The primary focus of this Manual is technical guidance for stormwater analysis methodologies required for land development projects, which are described in the UDC as hydrologic design methods. Related to stormwater management, the intent of the UDC requirements is such that *there will be no adverse impacts on the quality of natural surface waters, on the function of the floodplains, on off-site flood stages, and on natural system values and functions* UDC Article 2, Section 124-12(b)(7). As a guidance document, the Manual is not adopted by reference in the Sarasota County Code. Instead, this Manual serves to facilitate County stormwater reviews, expedite review times, and ensure that project submittals meet the County's standard of approval.

The Manual is organized to guide its user through the County's stormwater review process. Section 1 establishes the Manual's purpose and provides directions to the user on relevant review procedures by project type. Section 2 details review procedures Site Development, Subdivision, and Capital Improvement Plan submittals, Final Subdivision Plat submittals, and Earthmoving Permits as relevant to the County's Stormwater Division. Section 3 details County-required stormwater design criteria, including stormwater attenuation, floodplain compensation, and stormwater treatment criteria. Section 4 provides submittal data standards related to electronic data submittals. Sections 5, 6, and 7 discuss the Rational Method, Hydrograph Method, and Model Incorporation Method, respectively, which are hydrologic design methods approved by the County for land development. The appropriate hydrologic design method for a given project depends on the total project area and project impervious area. Section 8 provides additional technical guidance on select subjects common

to stormwater reviews. Lastly, Section 9 lists technical references that provide supplemental information to this Manual.

## 1.2 COMMUNITY NEED

Sarasota County was established in 1921 and adopted a Home Rule Charter in 1971. The County is home to around 400,000 permanent residents and includes over 550 square miles of land. Effective management of stormwater is a priority for the County, which receives over 50 inches of rainfall annually. During the late 1990s and early 2000s, the County experienced several community-wide flood events from named and unnamed storms resulting in over \$13 million in damage payments to local property owners through the Federal Emergency Management Agency (FEMA) National Flood Insurance Program. More recently, community-wide flooding has occurred after over 15 inches of rain fell over 3 days in August 2017, including 8 inches over 24 hours, as recorded at the Sarasota-Bradenton Airport. The unnamed August 2017 storm is roughly equivalent to a 100-year frequency rainfall event. These examples are part of a well-established history of flood-inducing rainfall events occurring in the County.

The stormwater criteria and hydrologic design methods in the UDC are the focus of this Manual and have evolved from this history to meet the County's need of protecting the health, safety, and welfare of residents through flood protection. The overriding goal of the state's stormwater management program and the County's Stormwater Development Review program is to ensure that pre-development site and watershed characteristics are maintained under post-development conditions as stated in Rule 62-40.431 of the Florida Administrative Code. The County's Stormwater Division is responsible for reviewing proposed development plans to ensure new development meets these standards. In Sarasota County, these standards notably include that all land development meets criteria for three design storms.

## 1.3 QUICK USER GUIDE

All land development projects within the County are required to submit an application for review consistent with the Site Development and Subdivision Plan Review Procedure unless explicitly exempt (Section 2). As described in UDC Article 13, Section 124-252(a)(1)a., if a Site Development Plan is required, then a complete stormwater management system must be provided. The system must be designed in accordance with Southwest Florida Water Management District (SWFWMD) criteria and County stormwater management criteria defined in the UDC and this Manual. The County's stormwater design criteria (Section 3) and submittal requirements (Section 4) apply to all submittals.

As part of these requirements, the applicant must determine existing (pre-development) and proposed (post-development) drainage conditions for the project. The hydrologic design method defines the approach to determine project drainage conditions and must be one of the Rational Method (Section 5), Hydrograph Method (Section 6), or Model Incorporation Method (Section 7). The appropriate hydrologic design method and submittal requirements depend on the project size, scope, and watershed impact. The Stormwater Division recommends applicants request a stormwater methodology meeting to establish the appropriate hydrologic design method, design criteria, and available data for a stormwater review submittal in addition to DRC meetings.

The County assesses flood protection on-site by level-of-service standards and off-site by adverse impacts. The method to determine off-site impacts also depends on the hydrologic design method as summarized in Table 1.1. In areas of known stormwater problems or with restrictive conveyances, the allowable proposed condition peak outflow(s) will be determined from best available data approved by the Stormwater Division. The Stormwater Division has developed stormwater models for several watersheds that commonly are the best available information for drainage conditions near the project area. The watershed models, referred to as *Basin Models* in the UDC and the remainder of this Manual, are only required to be directly used via the Model Incorporation Method when projects are greater than 35 acres in total area or include more than 8 acres of impervious area. The Model Incorporation Method is also required when land development impacts watershed conveyance, such as changes to a canal or County-owned conveyance.

**Table 1.1 Summary of Hydrologic Design Methods**

<b>Hydrologic Design Method</b>	<b>Project Area Characteristics</b>	<b>Existing Conditions</b>	<b>Proposed Conditions</b>	<b>Protection Against Adverse Off-site Impacts</b>
Rational Method	Total Project Area less than 10 acres AND Project Impervious Area less than 8 acres.	Determined by Applicant. Design Tailwater Conditions determined by County Basin Model.	Determined by Applicant. Must match provided Design Drawings.	Proposed Conditions peak outflow must be less than or equal to the existing conditions peak outflow. No decrease in on-site floodplain storage is allowed.
Hydrograph Method	Total Project Area less than 35 acres AND Project Impervious Area less than 8 acres.	Determined by Applicant. Model Boundary Conditions determined by County Basin Model.	Determined by Applicant. Must match provided Design Drawings.	Proposed Conditions peak outflow must be less than or equal to the existing conditions peak outflow. No decrease in on-site floodplain storage is allowed.
Model Incorporation Method	Total Project Area greater than or equal to 35 acres OR Project Impervious Area greater than or equal to 8 acres.	Determined by County Basin Model. Revised Existing Conditions may be submitted by Applicant.	Determined by Applicant. Must match provided Design Drawings.	No model-predicted adverse increase in off-site peak flood stage(s) is allowed. Adverse increase is any model-predicted peak-stage increase equal to or greater than 0.01 foot.

## 1.4 CONTACT INFORMATION AND FILE RETRIEVAL LOCATION

Questions regarding this Manual or the County’s stormwater review process should be directed to the Sarasota County Stormwater Division at 961-861-5000. The latest version of this Manual can be downloaded on an ftp site (<https://ftp.scgov.net/stormwater/Resources>).

## 2 SUBMITTAL REVIEW PROCEDURES

Land development review procedures are provided in detail within Article 5 of Sarasota County’s *Unified Development Code* (UDC), which is Chapter 124 of the Sarasota County Code. Required submittal reviews and procedures are typically discussed at the development review coordination (DRC) pre-submittal conference. Select information about review procedures is reproduced here specific to submittals that commonly require review by the Stormwater Division. Common submittals reviewed by the Stormwater Division include Site Development and Subdivision submittals, Final Subdivision Plat submittals, and Earthmoving Permit submittals. Earthmoving Permit review procedures are provided in detail within Article 12, Chapter 54 of the Sarasota County Code.

### 2.1 SITE DEVELOPMENT AND SUBDIVISION SUBMITTAL

Site Development and Subdivision submittal review procedures are established in UDC Article 5, Section 124-41 and are required for all land development within the County unless specifically exempt.

#### 2.1.1 ALLOWABLE EXEMPTIONS

The UDC recognizes the exemptions listed below from Site Development and Subdivision review procedures, UDC Article 5, Section 124-41(b)(1). The Stormwater Division does not determine project eligibility for exemption. All other land development within the County is required to abide by the Site Development and Subdivision review procedures. Exemption requests must be submitted to the County’s Planning and Development Services Department.

- One-family or two-family dwelling units on an individual lot or lots of record.
- Model homes in developments.
- Any increase of less than 2,000 square feet of impervious surface that does not change the location or number of existing facilities on site.
- Agricultural structures not requiring a Certificate of Occupancy.
- Earthmoving-only work authorized under the County’s Earthmoving Code.

#### 2.1.2 REQUIRED REVIEW PROCEDURES

Land development projects that include the subdivision of land must undergo two review procedures. Subdivision projects must receive Subdivision Plan approval through the Site Development and Subdivision review procedure and are also required to abide by the Final Subdivision Plat review procedure. Both procedures are generally characterized by the review procedure flow chart below, and component parts of the review procedure are established in UDC Article 5, Section 124-36.

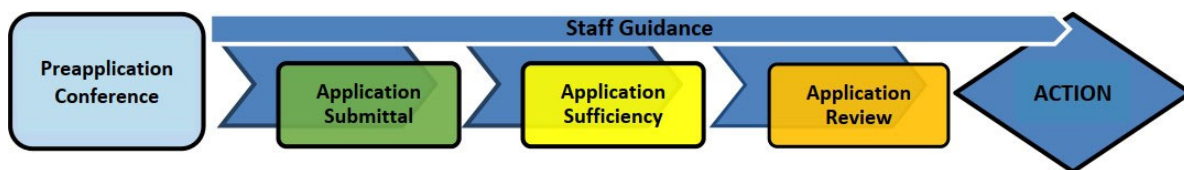

For all land development projects, the application must include the stormwater management system in the Construction Engineering Plans and Specifications submittal. Applications should include supporting information used to design the stormwater management system as detailed in this Manual. Although not required as part of the review procedures, **a stormwater methodology meeting is strongly recommended** to provide clarity on required stormwater management procedures and submittal requirements. The Stormwater Division recommends applicants request a stormwater methodology meeting in addition to the DRC pre-submittal conference.

Because of the community impact of capital improvement projects, additional points of review are required by the Stormwater Division for these projects. Submittals and reviews are required at 30-, 60-, and 90-percent design completion in addition to final design. The final design and related material should be included in the Site Development and Subdivision review. **Close coordination with the Stormwater Division is strongly encouraged at all stages of design for capital improvement projects.**

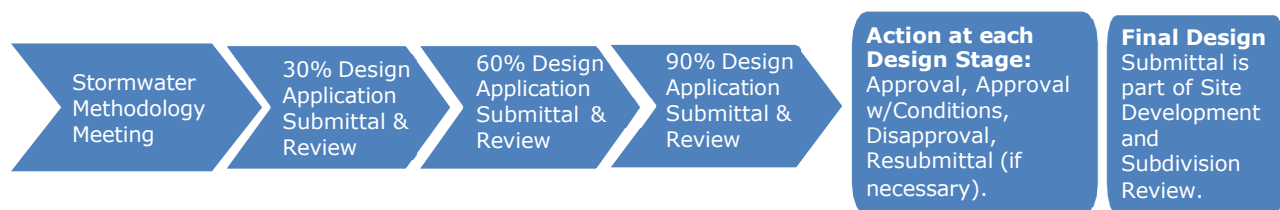

For Stormwater Division review of capital improvement projects, the 30-percent submittal should include an overall concept of the project, a signed-and-sealed survey of the project area, an initial layout of the proposed stormwater management system, the revised existing conditions information, and any preliminary stormwater attenuation, flood control and treatment calculations. The 60-percent submittal should not be submitted before the 30-percent submittal is approved and should include a complete draft of the proposed conditions and required stormwater analyses. The 90-percent submittal should include the final proposed conditions with the applicable documentation demonstrating compliance with required design criteria. The Stormwater Division typically uses the 100-percent submittal to verify that no stormwater-related changes occurred after the 90-percent submittal.

## 2.2 FINAL SUBDIVISION PLAT SUBMITTAL

Final Subdivision Plat review procedures are established in UDC Article 5, Section 124-42 and are required for all land development within the County that requires the subdivision of land unless specifically exempt. Applications for Final Subdivision Plat review will not be accepted by the County until a Subdivision Plan is approved through the Site Development and Subdivision review procedure. Given this, Stormwater Division reviews of Final Subdivision Plat submittals are typically focused on the items below.

- Conformity with the approved Site Development Plan and Subdivision submittal.
- Verification that stormwater-related easements (such as perpetual drainage easements, maintenance easements, etc.) are explicitly provided on the Plat or have been previously recorded and are referenced on the Plat by Official Record (OR) Book and Page. Provided easements must meet UDC requirements (UDC Article 18, Appendix C13a, C13b, C13c and C29).

- Verification that Certificate of Ownership and Delegation of Stormwater Management System Maintenance Agreement is included and appropriately completed (UDC Article 18, Appendix C23).
- Verification that subdivision floodplain information has been recorded and is appropriately referenced on the Cover Sheet by Miscellaneous Map Book and Page. The Stormwater Division **strongly recommends applicants submit subdivision floodplain information for review** prior to Miscellaneous Map Book recording.
- Review and approval of recorded subdivision covenants and restrictions as related to stormwater. Specific stormwater-related requirements are detailed below.

To protect the future integrity of constructed stormwater management systems and establish maintenance responsibilities for these systems, the Stormwater Division requires the following language be included in covenants and restrictions. Similar alternate language may be approved following review and approval by the Office of the County Attorney.

*The Surface Water Management System Facilities may not be altered without prior written approval from the Sarasota County Engineer or his designee.*

*The Declaration of Covenants Conditions and Restrictions may not be amended without prior written approval from the Sarasota County Engineer or his designee.*

*In the event the Association, or any successor organization, shall fail to adequately maintain the Stormwater Management System in accordance with Sarasota County standards, Sarasota County shall have the right, but not the obligation, to enter the Subdivision for the purpose of maintaining the Stormwater Management System. All expenses incurred by Sarasota County in maintaining the Stormwater Management System shall be assessed pro rata against the Lots and shall be payable by the Owners of the Lots within 60 days after receipt of a statement therefor. If any Owner fails to pay such assessment within such 60-day period, the assessment shall become a lien on such Owner's Lot which may be foreclosed by Sarasota County. The rights of Sarasota County contained in this restriction shall be in addition to any other rights Sarasota County may have in regulating the operation and development of the Subdivision.*

## **2.3 EARTHMOVING PERMIT SUBMITTAL**

Earthmoving not otherwise related to land development requires an Earthmoving Permit to comply with the Sarasota County Code. Earthmoving Permits are required to protect the County's natural environment and historical resources as well as the health, safety, and welfare of County residents. Earthmoving Permit review procedures are provided in detail within Article 12, Chapter 54 of the Sarasota County Code. A copy of the application form is provided as Attachment 1.

As part of earthmoving activities, proposed stormwater elements must meet design and analysis criteria detailed in the UDC and this Manual for land development. In addition, Stormwater Division reviews of Earthmoving Permit submittals are typically focused on the items below.

- Verification that proposed activities will not create flooding or health hazards by interference with the proper functioning of any public or private stormwater drainage system or natural flowage way.

- Verification that proposed activities maintain historic drainage patterns and inflow/outflow discharge points.
- Verification that proposed drainage ditches include a suitable berm width for maintenance operations and are in accordance with UDC Article 18, Appendices C13a, C13b, and C13c.
- Verification that the proposed activities will not result in a net loss of storage volume within the County-designated 100-year floodplain. For activities within the 100-year floodplain, applicants must provide cup-for-cup volumetric calculations demonstrating compensating volume.
- Verification that the proposed activities will not adversely affect implementation of any approved regional stormwater basin plan.
- Verification that the proposed activities will not adversely affect surface and groundwater levels.

## 2.4 SUBMITTAL REQUIREMENTS FOR STORMWATER DIVISION REVIEWS

Site Development and Subdivision submittals must meet the application requirements detailed in UDC Article 12, Section 124-230. Final Subdivision Plat submittals must meet the application requirements detailed in UDC Article 12, Section 124-234. Earthmoving permit submittals must meet the application requirements detailed in Section 54-345 of the Sarasota County Code, which includes reference to UDC Article 12, 13, 17, and 18 regarding stormwater requirements. At minimum, submittals requiring Stormwater Division review must include a Stormwater Management Plan, completed Stormwater Review Checklists and Design Summary Forms, which are available in UDC Article 18, and related supporting material and calculations that demonstrate compliance with stormwater criteria established in the UDC and this Manual. Significant detail related to these requirements is provided throughout this Manual, including:

- **Section 3** details stormwater design criteria and requirements. Stormwater management systems must meet the stormwater design criteria established in the UDC and this Manual. Pertinent information related to County design and level-of-service standards is provided in UDC Article 18, Appendices 13a, 13b, 13c, and 14. Stormwater management systems must also comply with state and federal stormwater design criteria.
- **Section 4** details Stormwater Division electronic data submittal requirements related to file type, format, and structure. This section includes requirements for submitted drawings, maps, supporting calculations, stormwater model data, and spatial data including geographical information system (GIS) and computer-aided design (CAD) information.
- **Sections 5, 6, and 7** provide more details on the three allowable hydrologic design methods for stormwater attenuation and flood control calculations and the unique aspects of each submittal type including method-specific submittal requirements. Allowable hydrologic design methods are determined by site characteristics including total area and impervious area, as outlined in Table 1.1 and stated in each method's applicable section in this Manual.
- **Section 8** provides additional technical guidance on items which commonly impact submittal requirements.

### 2.4.1 STORMWATER MANAGEMENT PLAN

A Stormwater Management Plan is required for all submittals requiring Stormwater Division review and specific plan requirements are listed in UDC Article 12, Section 124-230(a)(11). For clarity, the UDC requirements are summarized here. The Stormwater Management Plan must be signed-and-sealed by the Engineer of Record; define the project area, major stormwater conveyances, and stormwater management facilities for existing and proposed conditions; define required stormwater criteria and demonstrate that all applicable stormwater criteria have been met by the proposed design including stormwater attenuation and flood control, stormwater treatment, floodplain compensation, and stormwater level-of-service criteria; and indicate the responsible maintenance entity post-construction. Specifically, the plan should include or be supplemented with the following:

1. Site area and topographic map of the entire project. Section 4.2 establishes the additional submittal standards for maps.
2. Construction plan drawings. Stormwater design criteria are provided in Section 3.2. Section 4.1 establishes the additional submittal standards for construction plan drawings.
3. Proposed stormwater attenuation and flood control method, demonstration of no adverse off-site impact, and provided stormwater level-of-service. Calculations demonstrating no adverse off-site impact must be provided. The required calculations depend on the hydrologic design method. A summary table of internal pipe calculations must be provided demonstrating on-site stormwater level-of-service. Stormwater attenuation and flood control requirements are provided in Section 3.3. Section 4.3 establishes submittal standards for supporting calculations.
4. Additional supporting materials such as maps, model data, and spatial data as required for the hydrologic design method used. These materials and requirements are documented in the related hydrologic design approach sections (Sections 5, 6, or 7 as applicable). Section 4.2 establishes submittal standards for maps. Section 4.4 establishes submittal standards for stormwater models. Section 4.5 establishes submittal standards for spatial data, such as CAD and GIS.
5. Proposed treatment method, treatment volume required, treatment volume provided, and drawdown calculations. Stormwater treatment requirements are provided in Section 3.4. Section 4.3 establishes submittal standards for supporting calculations.
6. For proposed land development within a flood zone, floodplain compensation volumetric calculations must be provided if required by the hydrologic design method. For proposed land development within a floodway, a no-rise certification must be provided. Additional design criteria also apply for development within a flood zone or floodway and these requirements are provided in Section 3.5.



#### 2.4.2 STORMWATER REVIEW CHECKLISTS AND SUMMARY FORMS

The checklists and summary form listed below are required for all submittals. Attachment 2 also provides copies of the documents referenced below.

- Subdivision Plat and Site Development Plan Stormwater Review Checklist (UDC Article 18, Appendix C24).
- Construction Plan Stormwater Review Checklist (UDC Article 18, Appendix C25).
- Construction Plan Stormwater Design Summary (UDC Article 18, Appendix C26a) signed-and-sealed by the Engineer of Record.

A Construction Plan Stormwater Design Summary for Net Improvement (UDC Article 18, Appendix C26b) signed-and-sealed by the Engineer of Record is also required if net improvement stormwater treatment criteria are applicable to the project.

# CHAPTER 2

## STORMWATER DIVISION REQUIREMENTS

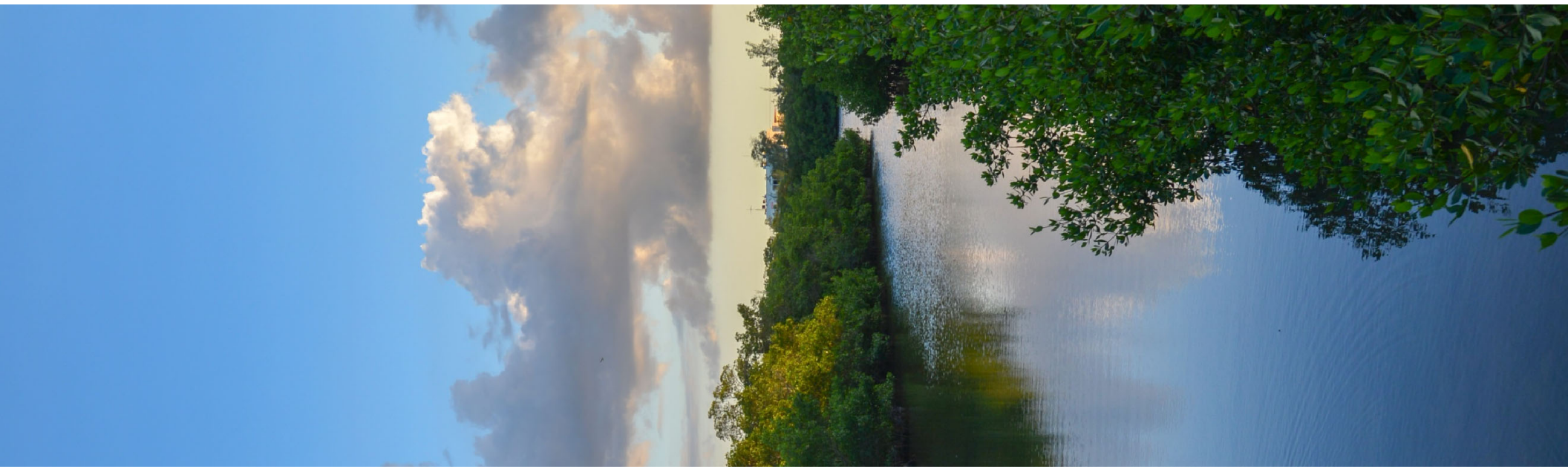

### 3 STORMWATER DESIGN AND ANALYSIS CRITERIA

The *Unified Development Code* (UDC) discusses stormwater-related design criteria in multiple Articles and Appendices, most notably Articles 9 and 13 and Appendices in Article 18. Attachment 3 provides copies of pertinent appendices. The stormwater management system must meet the stormwater design criteria established in the Sarasota County UDC and must comply with state and federal stormwater design criteria. The Southwest Florida Water Management District (SWFWMD) regulates stormwater management systems for land development within the County through the Environmental Resource Permitting Rules in the Florida Administrative Code (FAC) Chapter 62-330.

The County- and SWFWMD-required stormwater design criteria are applicable to all land development. Some County criteria are stricter than SWFWMD criteria. The County allows applicants to use one of three hydrologic design methods to demonstrate compliance with stormwater attenuation and flood control criteria. Applicants must also demonstrate compliance with County and SWFWMD stormwater treatment criteria. Additional criteria are required for land development within flood zones.

Applicants may choose to submit revised existing condition information for any land development or a master stormwater management plan for phased land development. Additional criteria are required for each type of submittal.

#### 3.1 COMPARISON OF COUNTY AND SWFWMD CRITERIA

The UDC explicitly adopts SWFWMD criteria provided in SWFWMD’s *Permit Information Manual* and applicants are directed to SWFWMD’s *Environmental Resource Permit (ERP) Applicants Handbook I and II* for further guidance on state criteria. The County requires additional stormwater design criteria that are established in the UDC as summarized in Table 3.1.

**Table 3.1 Summary of Additional Stormwater Design Criteria**

<b>Design Criteria</b>	<b>Sarasota County</b>	<b>SWFWMD</b>
Regulated design storm return periods	10-year, 25-year, and 100 year	25-year
Treatment volume for dry retention ponds	1 inch of rainfall	0.5 inch of runoff
Treatment volume for wet detention ponds	1 inch of runoff	1 inch of runoff
Treatment volume when discharging directly into saltwater tidal systems, bays, or the gulf	1.5 X required treatment	No additional treatment criteria
Demonstration of no adverse impact via watershed-scale modeling <sup>1</sup>	Required when land development equals or exceeds 35 acres total area or 8 acres impervious area	Not required for land development
Definition of adverse off-site impact	0.01 foot or more of model-predicted stage increase <sup>2</sup>	No quantitative definition

<sup>1</sup> SWFWMD uses presumptive flow criteria (pre-development peak discharge greater than or equal to post-development peak discharge) to protect against adverse impacts. Sarasota County uses presumptive flow criteria for projects less than 35 acres total area and less than 8 acres impervious area.

<sup>2</sup> The County may allow model-predicted stage increases that do not create adverse off-site impacts.

## 3.2 STORMWATER DESIGN

In general, the stormwater management system must be designed for long life, low cost, and ease of maintenance. To facilitate stormwater system longevity and maintenance, the following design criteria must be met:

- Drainage structures will be designed to minimize ponding within the structure.
- The stormwater system will require only normal maintenance practices following construction.
- Stormwater ponds will provide at least 0.5 foot of freeboard for the 4330|hdu/570krxu design storms runoff while meeting County roadway level-of-service standards (UDC Article 18, Appendix C14).
- Stormwater pond berms will have a minimum top width of 2 feet. This criterium also applies to all water features.
- Drainage ditches will include a suitable berm width for maintenance operations and be in accordance with UDC Article 18, Appendices C13a, C13b, and C13c.
- All access berms or berms at stormwater facilities will be cleared of trees, shrubs, and other obstructions and provide adequate equipment access.
- Dry detention ponds that include man-made filter systems and have a design distance from the filter system to the most remote point of the pond bottom greater than 150 feet will have a concrete low-flow v-channel connecting these locations. The concrete channel will be a minimum of 2 feet wide, 2 inches deep, and 4 inches thick.
- Only vinyl-coated chain-link or decorative aluminum fences are allowed around stormwater management systems. Other chain-link and wood fences are prohibited.
- Inlets and inlet spacing will be designed to accept 100 percent of the 430|hdu/580|hdu design storms runoff while meeting County roadway level-of-service standards (UDC Article 18, Appendix C14). The design distance to meet spacing requirements will depend on the site characteristics.
- Floodplain compensation must be provided where warranted to prevent adverse off-site impacts. Compensation areas must be hydraulically connected to the stormwater management system. A cup-for-cup approach to determine compensating volume must be used when adverse off-site impacts are not explicitly modeled. A cup-for-cup approach is demonstrated graphically in Attachment 4.
- Utilities crossing County-maintained ditches will be designed in accordance with UDC Article 18, Appendix C16.
- Voids in gravel or similar material may be used in the calculations of treatment or attenuation storage only when the percent void space as constructed is demonstrated to be 80 percent of the testing laboratory values for the selected aggregate(s), if obtained and certified by a Florida-licensed geotechnical professional or as demonstrated by the manufacturer's or supplier's specification. The applicant must provide the manufacturer's or supplier's specifications or published documentation to support the provided values.
- Side-lot drainage easements must be provided where warranted.
- Stormwater management systems will include special engineering design features to minimize oil, suspended solids, and other objectionable materials polluting downstream waters.
- Stormwater management systems must meet the stormwater attenuation and flood control criteria established in this section.
- Stormwater management systems must meet the stormwater treatment criteria established in this section.

The **Stormwater Division encourages regional stormwater facilities** in lieu of on-site facilities. Approval of regional stormwater facilities requires interested parties to present their proposal to the Regional Facilities Committee. At a minimum, the proposal will demonstrate that the regional facility(s) adequately serves the intended service area without adverse off-site impacts.

The **Stormwater Division discourages underground stormwater storage facilities.** Underground facilities are only acceptable when adequate justification and demonstration of reliable performance is provided. At a minimum, underground facilities will provide easy access for inspection and maintenance.

### 3.3 STORMWATER ATTENUATION AND FLOOD CONTROL

The County requires stormwater management systems provide adequate attenuation to protect on-site and off-site facilities from flooding. The County assesses flood protection on site by level-of-service standards and off site by adverse impacts. To ensure stormwater management systems provide adequate flood protection, applicants must provide drainage calculations that:

- Are based on the 430|hdu/580|hdu/dqg 4330|hdu/570krxu design storms.
- Determine the existing and proposed conditions.
- Demonstrate that the proposed conditions meet the UDC-required level-of-service (UDC Article 18, Appendix C14).
- Demonstrate that no inundation of habitable structures occurs in the proposed conditions.
- Demonstrate that no off-site discharge occurs in the proposed conditions except through approved outfalls.
- Demonstrate that no adverse off-site flood impacts occur in the proposed conditions.

#### 3.3.1 HYDROLOGIC DESIGN METHODS

Drainage calculations used to develop existing and proposed drainage conditions must be based on a hydrologic design method approved by the Stormwater Division. The Stormwater Division allows three hydrologic design methods. Applicants must use an appropriate hydrologic design method depending on the project site characteristics including total land area, impervious area, and watershed impact. The three allowable hydrologic design methods are listed below along with the relevant section of this Manual that provides additional information on each:

- Rational Method (Section 5)
- Hydrograph Method (Section 6)
- Model Incorporation Method (Section 7)

Table 3.2 presents which hydrologic design methods are allowable given project total land area and impervious area. The Model Incorporation Method should be used for any project where site characteristics do not qualify for either the Rational Method or Hydrograph Method. The Stormwater Division **strongly recommends applicants request a stormwater methodology meeting** to establish the appropriate hydrologic design method for a submittal.

**Table 3.2 Approved Hydrologic Design Method Use by Project Characteristics**

Hydrologic Design Method	Total Land Area	Impervious Area
Rational Method	Less than 10 acres.	Less than 8 acres.
Hydrograph Method	Less than 35 acres.	Less than 8 acres.
Model Incorporation Method	Greater than or equal to 35 acres.	Greater than or equal to 8 acres.

### 3.3.2 ADVERSE OFF-SITE IMPACTS

The County assesses flood protection off site by adverse impacts. The method to determine off-site impacts depends on the hydrologic design method and is described below. The Stormwater Division may require similar analyses for any method using additional design storms if site and watershed characteristics warrant. The Stormwater Division **strongly recommends applicants request a stormwater methodology meeting** to establish the appropriate methods for a submittal.

When the Rational Method (Section 5) is used, no direct calculation of off-site flood levels is required, so presumptive flow criteria and compensating storage volume are used to demonstrate no adverse off-site impacts. Drainage calculations must demonstrate that proposed condition outflow is less than or equal to existing condition outflow for the 430|hdu/580|hdu/dgg 4330|hdu/570krxu design storms. Tailwater conditions for proposed outfalls must be established based on a County Basin Model or other Stormwater Division approved information. Applicants must also demonstrate that compensating floodplain storage volume equals or exceeds storage volume removed from the 100-year floodplain. Compensating storage volume must be *cup-for-cup* and consider volume loss between the seasonal high-water elevation and base flood elevation.

When the Hydrograph Method (Section 6) is used, no direct calculation of off-site flood levels is required, so presumptive flow criteria and compensating storage volume are used to demonstrate no adverse off-site impacts. Drainage calculations must demonstrate that proposed condition outflow is less than or equal to the existing condition outflow for the 100-year design storm. Model boundary conditions must be established based on a County Basin Model or other Stormwater Division approved information. If off-site model nodes are required to best match node locations of the County Basin Model, no stage increases are allowed at off-site nodes greater than or equal to 0.01 foot. Applicants must also demonstrate that compensating floodplain storage volume equals or exceeds storage volume removed from the 100-year floodplain. Compensating storage volume must be *cup-for-cup* and consider volume loss between the seasonal high-water elevation and base flood elevation.

When the Model Incorporation Method (Section 7) is used, potential off-site flood impacts are determined by the County Basin Model. Adverse off-site impacts are defined as predicted peak-stage increases greater than or equal to 0.01 foot at any model node. While compensating floodplain volume may be required to meet this criteria, *cup-for-cup* volumetric calculations are not required in addition to County Basin Model simulations. Final determination of potential adverse off-site impacts will be made by the Stormwater Division.

### 3.3.3 LEVEL-OF-SERVICE

The County assesses flood protection on site by level-of-service standards (UDC Article 18,

Appendix C14). Applicants must demonstrate that proposed stormwater management system meets the County’s level-of-service criteria for evacuation, arterial, collector, and neighborhood roads. Applicants must also demonstrate that parking areas meet level-of-service criteria and that any proposed flooding of open space does not compromise public health and safety. The allowable flood depths that meet level-of-service criteria are summarized in Table 3.3.

**Table 3.3 Allowable Flood Depth by Design Storm Return Period**

Location	5-year	10-year	25-year	100-year
Evacuation Roadway	Not Allowed	Not Allowed	Not Allowed	Not Allowed
Arterial Roadway	Not Allowed	Not Allowed	Not Allowed	6 inches or less
Collector Roadway	Not Allowed	Not Allowed	6 inches or less	9 inches or less
Neighborhood Roadway	Not Allowed	6 inches or less	9 inches or less	12 inches or less
Parking Areas	3 inches or less	9 inches or less	9 inches or less	12 inches or less
Open Space	Flooding of open space is acceptable if it does not compromise public health and safety.			

Proposed level-of-service must be documented in a summary table that includes *internal pipe calculations*. At minimum, the summary table must include the information listed below. Internal pipe calculations using the Rational Method are discussed further in Section 5.3. Other allowable methods for internal pipe calculations are provided in Section 8.3.

- Junction Name, Type, Location, Rim Elevation, and Associated Pipe Segment.
- Level-of-Service Design Storm Tested, Allowable Flood Depth, and Proposed Flood Depth.
- Contributing Basin Area, Time of Concentration, and Total Inflow to Pipe Segment.
- Proposed Pipe Design Information, Hydraulic Grade Line, and Peak Discharge.

Drainage calculations for proposed conditions must also demonstrate no inundation of habitable structures and no off-site discharge occurs except through approved outfalls.

### 3.4 STORMWATER TREATMENT

Adequate protection for downstream water quality must be provided by the proposed stormwater management system. Under no circumstance will discharge from the stormwater management system be allowed to cause or contribute to a violation of water quality standards in Waters of the State. To accomplish this treatment goal, stormwater runoff from the area being developed or redeveloped shall be treated by the stormwater management system. Unlike stormwater attenuation and drainage calculations, the County does not require specific calculation methods for stormwater treatment. To ensure stormwater management systems provide adequate stormwater treatment, applicants must provide:

- Stormwater treatment calculations that demonstrate County-required treatment volume is provided.
- Stormwater treatment calculations that demonstrate SWFWMD-required drawdown of treatment volume is met.
- Plan drawings that identify littoral zones per County requirements.
- Plan drawings that identify wetland protection facilities per County requirements.

### 3.4.1 TREATMENT VOLUME

The County's requirement for treatment volume is based on presumptive criteria that have been historically established in the state. The water-quality-treatment method must also meet water-quality-treatment design criteria required by SWFWMD.

Most stormwater management systems in the County use either wet-detention or dry-retention facilities for water quality treatment of runoff. To meet County criteria, stormwater management systems that use a wet-detention facility must be designed to treat 1 inch of runoff. Stormwater management systems that use other types of treatment facilities, such as dry retention, must be designed to treat runoff from the first 1 inch of rainfall. The depth of runoff produced from 1 inch of rainfall depends on the rainfall-runoff-response but is typically less than 1 inch of runoff. Stormwater management systems discharging directly into saltwater tidal systems, bays, the Gulf, or Outstanding Florida Waters must be designed to treat 1.5 times the volume required for the selected treatment system.

When this Manual was developed, SWFWMD required wet detention systems to discharge the full treatment volume within 120 hours but not more than half the treatment volume within the first 60 hours or be designed to meet Conservation Wet Detention criteria. Dry retention systems were required to discharge the full treatment volume within 72 hours. For wet detention and dry retention, only volume recovered within the first 36 hours was considered as available storage volume for flood control. Applicants should review the most recent SWFWMD guidance for Environmental Resource Permitting, provided at the time of this Manual in *Applicant's Handbook Volume II*.

In addition to SWFWMD required treatment volume recovery, the County requires dry retention systems to discount vertical infiltration rates by a factor of safety of 2. Accordingly, dry retention systems must discharge the full treatment volume within 36 hours to meet County and SWFWMD criteria.

As an alternative to volume-based treatment requirements, stormwater management systems will be approved that provide net water quality improvements as defined below. Demonstration of the net improvements must be accompanied by a completed Net Improvement form (UDC Article 18, Appendix C26b):

- For projects within the watershed of a waterbody listed as impaired by the Florida Department of Environmental Protection (FDEP) or US Environmental Protection Agency (EPA), a load reduction of the listed pollutants must be demonstrated.
- For other project areas, a reduction of mean annual runoff must be demonstrated. The reduction must be based on local long-term daily rainfall data of at least 15 years.

### 3.4.2 LITTORAL ZONE

Littoral zones are required for stormwater ponds when the project, either singularly or cumulatively if constructed in phases, includes a wet detention pond or system of wet detention ponds greater than or equal to 1 acre. Littoral zones are also required for stormwater ponds of any size that directly connect to a native habitat area or watercourse. Additional detail on littoral zone requirements is provided in UDC Article 9, Section 124-178.



### 3.4.3 WETLAND PROTECTION

Wetland native habitats must be protected in accordance with the UDC Article 9, Section 124-172(f)(2). Stormwater runoff from impervious surfaces must be pre-treated before discharging to wetlands. Pre-treatment may be in the form of sediment sumps, baffles, grassed swales, or similar technology approved by the Stormwater Division. Stormwater discharge to natural wetlands must be done by overflow and spreader swales to avoid degradation of the ecosystem. Discharge facilities must be designed and constructed in accordance with all applicable regulations so that the discharge does not violate applicable local, state, or federal water quality standards or degrade the quality of the receiving waterbody.

## 3.5 DEVELOPMENT WITHIN A FLOOD ZONE

Areas within Sarasota County denoted as a Special Flood Hazard Area (SFHA) or Community Flood Hazard Area (CFHA) are subject to periodic inundation of flood waters, which result in loss of life and property, health and safety hazards, disruption of commerce and governmental services, extraordinary public expenditures for flood protection and relief, and impairment of the tax base, all of which adversely affect the public health, safety and general welfare. These flood losses are caused by the cumulative effect of obstructions in floodplains causing increases in flood heights and velocities, and by the occupancy in SFHAs and CFHAs by uses vulnerable to floods or hazardous to other lands which are inadequately elevated, floodproofed, or otherwise unprotected from flood damages. To protect County residents against future losses, the County has adopted several provisions as within Chapter 54 of the Sarasota County Code. Provisions pertinent to Stormwater Division reviews are summarized below.

- Development in floodways, such as fill, new construction, substantial improvements or other development activities is prohibited unless a *no-rise certification* is provided demonstrating that encroachments shall not result in any increase in flood levels within the community (Chapter 54, Article XVI, Sec. 54-515 of the Sarasota County Code).
- Development in flood zones, such as fill, new construction, or substantial improvements is prohibited unless no adverse off-site impacts are demonstrated in compliance with Section 3.3. Demonstrated compliance requires a cup-for-cup provision of compensating floodplain volume unless the Model Incorporation Method is used for hydrologic design.
- In numbered A or AE Zones, the lowest floor elevation must be designed to be at or above the Base Flood Elevation (BFE) plus one foot, the elevation required by the Florida Building Code, or the local CFHA elevation (100-year 24-hour peak stage) plus 1.0 foot, whichever is greater.
- In numbered V or VE Zones the use of fill for structural support is prohibited. The use of fill is also prohibited in Coastal A Zone (CAZ) areas seaward of the Limit of Moderate Wave Action (LiMWA). Limited non-compacted fill may be used around structure perimeters for landscape and aesthetic purposes provided the fill will wash out by storm surge.
- In unnumbered A Zones the lowest floor elevation must be designed to be at or above the 100-year 24-hour peak stage plus 1.0 foot or at least two feet above the highest adjacent grade.
- Any person who alters or relocates a portion of any watercourse shall demonstrate with appropriate calculations that the flood carrying capacity of the watercourse will be maintained (Chapter 54, Article XVI, Sec. 54-517(b)7 of the Sarasota County Code).

The County requires no-rise certifications for land development that occurs within a regulated floodway to demonstrate compliance with the National Flood Insurance Program, which states that the County must:

*Prohibit encroachments, including fill, new construction, substantial improvements and other development within the adopted regulatory floodway unless it has been demonstrated through hydrologic and hydraulic analyses performed in accordance with standard engineering practice that the proposed encroachment would not result in any increase in flood levels within the community during the occurrence of the base (100-year) flood discharge.*

The Stormwater Division considers land development to impact the floodway if any areas disturbed by proposed construction are within regulated floodway limits. In general, no-rise certifications must meet the data development and model standards outlined in this Manual and by the Federal Emergency Management Agency (FEMA). When this Manual was developed, the latest FEMA guidance was provided in Floodway Analysis and Mapping Guidance Document 79 (FEMA, 2019). Applicants are encouraged to contact FEMA Region 4 for the latest guidance on procedures for no-rise certifications.

At minimum, a submitted no-rise certification will:

- Include a narrative summary of the project and provided no-rise analysis.
- Be based on and include an existing condition model that includes sufficient cross-section detail in the project area.
- Be based on and include a proposed condition model that is derived from the existing condition model.
- Include a table summary of model predicted peak stages for each condition.
- Include a statement attesting to the results that is signed-and-sealed by a Florida-licensed professional engineer.
- Be consistent with the latest FEMA guidance.

The Stormwater Division allows the Hydrologic Engineering Center's River Analysis System (HEC-RAS) to be used as the stormwater model software in lieu of ICPR4 specifically for no-rise certifications. If HEC-RAS is used, the HEC-RAS data must be consistent with the corresponding ICPR4 model data, support calculations provided by the applicant, and US Army Corps of Engineers (USACE) documentation and guidance.

### **3.6 REVISED EXISTING CONDITIONS**

Applicants may request to revise available existing conditions information. Changes from previously established existing drainage conditions to revised existing drainage conditions must be based on more accurate information. Most commonly, revised existing conditions are proposed by applicants using the Model Incorporation Method and are based on a signed-and-sealed site-specific survey. The site-specific survey must demonstrate existing off-site flow patterns by including spot elevations that extend 50-feet beyond the property limits and including off-site flow arrows or contours. The Stormwater Division **strongly recommends applicants request a stormwater methodology meeting** to establish the appropriate existing conditions for a submittal.

Applicants are advised that the Stormwater Division will make final determinations on whether data proposed for use to generate revised existing conditions are more accurate than data

used to previously establish conditions of the project site. Applicants are also advised that proposed drainage conditions will only be reviewed by the Stormwater Division after revised existing drainage conditions have been reviewed and approved.

### 3.7 MASTER STORMWATER MANAGEMENT SYSTEMS

When land development is planned for construction in phases, such as common to Developments of Regional Impact (DRIs), Developments of Critical Concern (DOCCs), or similar, applicants may choose to submit a Master Development Plan that includes a Master Stormwater Management System. If land development submittals will be made under a Master Development Plan, the Master Stormwater Management System must be completely designed, submitted, and approved before the submittal of the first Site Development Plan for the related land development. The Master Stormwater Management System must meet all applicable criteria provided in this Manual and the UDC. Documentation for the Master Stormwater Management System must also include the items listed below and provided information must be updated at each phase submittal. If deviations from the original Master Stormwater Management System are proposed during a subsequent submittal, these items must be clearly highlighted for review by the Stormwater Division.

- A project map that identifies and illustrates the project boundary, stormwater facilities proposed for the Master Stormwater Management System, and delineations for contributing areas (i.e., model basins) draining to and being managed by the facilities. This map should also identify planned project phases.
- A project map that identifies and illustrates all the components of the Master Stormwater Management System. Components include lakes, ponds, wetland areas, and floodplain compensation areas and their respective stormwater controls and interconnecting conveyance systems. This map should also identify planned project phases.
- Design details for control structures, weirs, or other conveyances that act as stormwater controls for the Master Stormwater Management System for all phases, temporary phases, and final development.
- Relevant elevation data for floodplain storage areas (lakes, ponds, and floodplain-compensation areas) including but not limited to seasonal high-water level (SHWL), normal/control water level (NWL/CWL), and design high-water level (DHWL) for the 100-year design storm.
- Detailed model schematic maps for existing and proposed conditions that are consistent with the corresponding stormwater models, supporting calculations, Master Stormwater Management System, and other supporting documentation.
- Calculations demonstrating how stormwater attenuation and flood control and stormwater treatment criteria will be met as development occurs and when development is complete.
- A spreadsheet or tabulation within a drawing that establishes planned impervious area for specific *defined areas* for the Master Stormwater Management System (e.g., square feet per lot, per phase, per stormwater facility, or per model basin).

Once approved, the Stormwater Division will use the Master Stormwater Management System submittal as a guide to review and approve future Site Development Plan submittals. For example, the Stormwater Division will use the planned impervious area associated with the Master Stormwater Management System submittal to establish allowable impervious area for future Site Development Plan submittals. Accordingly, these impervious area summaries must be updated with each submittal to identify how much of the impervious area was approved

for each defined area for the Master Stormwater Management System, how much has been built prior to the submittal, how much is proposed with the submittal, and how much allowable impervious area remains for each defined area following construction of the proposed improvements within the submittal. To facilitate Stormwater Division review of the Site Development Plan submittals, impervious area information should be in the form of a tracking log or similar instrument. The Stormwater Division **strongly recommends applicants request a stormwater methodology meeting** to establish requirements for the Master Stormwater Management System submittal, appropriate tracking logs, and future Site Development Plan submittals.

### 3.8 REQUEST FOR VARIANCE FROM STORMWATER CRITERIA

Applicants are advised that proposed **variances from stormwater criteria outlined in this Manual and in the UDC are strongly discouraged** by the Stormwater Division. Applicants considering a variance request must submit appropriate justification for review by the County Engineer before Site Development and Construction Plan approval. Typically, variance requests will be submitted to Planning and Land Development, who will distribute the request to the appropriate reviewers, such as the Stormwater Division when applicable. The County Administrator has delegated authority to approve variance requests to the County Engineer. Stormwater Division reviews of variance requests will be made on a case-by-case basis and will result in recommendations to the County Engineer who is responsible for approval of all variance requests from UDC criteria. Minimum requirements for two common variance requests are described below.

#### 3.8.1 VARIANCE FOR STORMWATER ATTENUATION CRITERIA

Stormwater attenuation requirements are established in Section 3.3 of this Manual and UDC Article 13, Section 124-252(a)(1)e.1. for land development of 35 acres or less. Additionally, UDC Article 5, Section 124-46(c)(1)b.11. outlines general criteria for a variance from requirements for the Model Incorporation Methodology. At a minimum, the following criteria must be met for the Stormwater Division to recommend an Administrative Adjustment:

- The submittal must conform with all other requirements outlined in this Manual outside the specific variance criteria.
- The Engineer of Record must attend a stormwater methodology meeting to discuss and obtain approval of the most appropriate County Basin Model to start with as the existing conditions model.
- The stormwater management system must improve off-site drainage conditions by providing a decrease in proposed condition flood elevations of 0.01 foot or more for the 100-year design storm to a minimum of 50 percent of nodes within 0.5 mile upstream and downstream of the site along hydraulically connected conveyances.
- Improvements should be demonstrated in the 10-year and 25-year storm events.
- No increase in proposed condition flood stage at any node is allowed in the watershed model for the 10-year, 25-year, and 100-year design storms.
- If the starting County Basin Model is in Interconnecting Channel and Pond Routing Model Version 3 (ICPR3) and the Engineer of Record wants to convert the model to ICPR4, then the Stormwater Division's model conversion procedures must be followed. Conversion procedures are discussed further in Section 8.10.

### 3.8.2 VARIANCE FOR EASEMENTS

All drainage easements, should be recorded as described in the UDC Article 13, Section 124-252 (c)(4)b. and Appendices C143 and C29. No development should take place within the easements per the UDC Section 124-255(c)(4)d.

Side lot easements should be 10 feet total centered on the side lot lines and may be reduced to a minimum of three feet subject to the criteria in the UDC Section 124-255(c)(4)b.1 by code without a variance. A variance is needed if the side lot easement width is less than 3 feet total centered on the side lot line.

Rear lot easements should be at least 16 feet in width (8 feet on each lot) unless closed drainage easements are required per Appendix C29. Where water or sewage lines will not be installed in street rights-of-way or accessways, and easement of 20 feet should be provided. Reductions in front and rear lot easements are subject to the UDC Section 124-255(c)(4)b.2 and Section 124-46 and a variance is required to demonstrate maintaining adequate width to assure equivalent function and maintenance.

## 4 DATA DELIVERY STANDARDS

Presenting construction or survey-related spatial data as one or more plan sheets is referred here to as a *drawing*. Spatial data developed to support stormwater analysis discussed in Sections 5 through 7 of this Manual are referred to here as *model-related spatial data*. Presenting model-related spatial data as a figure is referred here to as a *map*. Presenting engineering analysis is referred to here as *supporting calculations*. Applicant submittals must contain an electronic copy of all relevant drawings, maps, supporting calculations, stormwater models, and model-related spatial data. Applicants must submit data in an organized manner. A submittal data location key sheet is provided as Attachment 5 to facilitate Stormwater Division review.

The Stormwater Division accepts spatial data in geographical information system (GIS) and computer-aided design (CAD) format. However, **the Stormwater Division strongly prefers spatial data be submitted in GIS format** except for drawings, which should be submitted in CAD format. The Stormwater Division has made significant investments in existing GIS spatial data. These data are an integral part of the Stormwater Division's data management, including model-related GIS data such as basin (polygon), link (polyline), and node (point) data; hydrologic "time of concentration" flow paths (polyline); hydraulic cross-sections (polyline); and model-predicted floodplains (polygon). The County also maintains watershed topography as GIS data in the form of digital terrain models. The Stormwater Division encourages applicants use existing GIS data to support stormwater design.

All spatial information should be generated use the horizontal and vertical coordinate system information listed below unless otherwise directed by the Stormwater Division.

- State Plane Coordinate System.
- Florida West Zone (Zone 3626 – FIPS 0902).
- North American Datum of 1983 (NAD83) (2011 Adjustment).
- North American Vertical Datum of 1988 (NAVD88) vertical units in US Survey Feet.

### 4.1 DRAWINGS

Drawings of site-specific survey, proposed site plan, construction plan, and any other drawing related to the stormwater management system must adhere to all applicable UDC requirements. At a minimum, drawings must be at an appropriately readable scale and prepared by a Florida-licensed professional engineer. The drawings must be consistent with the information used for maps, supporting calculations, stormwater models, and model-related spatial data outlined in this Manual. Electronic copies of drawings should be provided in CAD-compatible formats.

Requirements specific to drawings submitted to fulfill Stormwater Management Plan requirements, as listed in UDC Article 12, Section 124-230(a)(10), are summarized and expanded below for clarity. Specifically, drawings should:

1. Show the project boundary and any project phasing. Phasing must be consistent with the provided stormwater models and supporting calculations.

2. Show major stormwater management facilities including lakes, ponds, floodplain compensation areas, basin boundaries, stormwater controls, and/or interconnecting stormwater conveyance systems.
3. Show existing and proposed swales, ditches, canals, storm sewers, structures, littoral areas, detention basins, applicable cross-sections, contours and grades, and discharge locations.
4. Show existing and proposed rights-of-way, drainage easements, outfall locations, and any critical restrictions.
5. Show Federal Emergency Management Agency (FEMA) special flood hazard (SFHA) elevation/delineation, floodway delineation, and Community Flood Hazard Area (CFHA) elevation/delineation.
6. Show drainage basin boundaries used for calculations of existing and proposed drainage conditions with flow directions, contours, and discharge locations.
7. Include detail sheets for major components of the stormwater system including but not limited to control structures and weirs.
8. Include call-outs for floodplain storage areas (lakes, ponds, and floodplain-compensation areas) with relevant elevation data including but not limited to seasonal high-water level (SHWL), normal/control water level (NWL/CWL), and design high-water level (DHWL) for the 100-year design storm.
9. Include call-outs or summary tables that detail the allowable impervious area for specific areas called out on the plan such as square feet per lot, square feet per phase, square feet per modeled basin, etc., that have been established by a Master Stormwater Management Plan. Impervious quantities must be documented by impervious type: roofs and driveways, streets, sidewalks, ponds, wetlands, etc. Total impervious area and percentage of impervious area must be clearly stated on the cover page of each plan set.

## 4.2 MAPS

Maps are typically used in concert with supporting calculations to demonstrate compliance with stormwater criteria established in this Manual. As such, maps should include sufficient information for the Stormwater Division to confirm compliance. For example, maps of model schematic must cover the entire project area and all points of connection to County Basin Models. Table 4.1 provides the format requirements for map legends. At a minimum, all maps must contain the information listed below in addition to presenting the relevant data:

- Title.
- Applicant name and contact information.
- Date of last revision.
- Legend.
- North arrow.
- Scale bar.

**Table 4.1 Map Legend Format Requirements**

<b>Legend Entry</b>	<b>Feature Data Requirements</b>
Model Basin	Model basins should be clearly displayed.
Model Node	Model nodes should be labeled with their model identification (ID).
Model Link	Model links should be displayed by link type: pipe, drop structure, channel, weir, or rating curve.
Modeled Cross-Section	Model cross-sections should be labeled with their model ID. Cross-sections used for Hydrologic Engineering Center's River Analysis System (HEC-RAS) bridge modeling should be labeled by river station.
Hydrologic Flow Path	Flow paths used for hydrologic calculations (time-of-concentration) should clearly display flow regime type: sheet flow, shallow concentrated flow, pipe flow, and channelized flow.
Floodplain	Model-predicted floodplains should be easily differentiated by storm event and model condition.
Data Source and Date	Common examples: Elevation (Surveyor; date); Site Boundary (Engineer of Record; date); Floodplain (Engineer of Record; date); Soils (Natural Resources Conservation Service [NRCS]; date)

### 4.3 SUPPORTING CALCULATIONS

Supporting calculations must be provided to demonstrate that the stormwater management system meets the criteria established in this Manual. The **supporting calculations must be consistent with drawings, maps, other supporting calculations, and stormwater models**. For example, the stormwater model naming scheme for pipes should match construction plan drawings and supporting tables. If necessary, a cross-reference table should be provided so that the Stormwater Division can readily confirm compliance across all submitted material. Electronic submittals, such as excel spreadsheets, should be organized such that intermediate calculations are presented, readily identifiable, and easily reviewable. Supporting calculations commonly include:

- Hydrologic and hydraulic calculations to support stormwater inlet, pipe, and pond outfall design. Including, but not limited to, time of concentration and internal pipe calculations. These calculations are applicable to all hydrologic design methods.
- Stormwater treatment calculations to determine stormwater pond treatment volume and recovery time. These calculations are applicable to all hydrologic design methods.
- Hydraulic attenuation calculations to size stormwater ponds when the Rational Method is used for hydrologic design.
- Curve number calculations to support stormwater modeling when the Hydrograph Method or Model Incorporation Method is used for hydrologic design.
- Compensating volume calculations when the Rational Method or Hydrograph Method is used for hydrologic design.



## 4.4 STORMWATER MODEL DATA

When a stormwater model is used for hydrologic design, electronic copies of the model files and results must be provided. Figure 4.1 shows how ICPR4 model data are organized by ICPR4’s folder package. ICPR4 requires all directories within the folder package to be present, even if some directories contain no data, to successfully execute the model contained in the \*.i4p file. Accordingly, all directories must be included in applicant submittals.

**Figure 4.1 Example ICPR4 Package Folder Structure**

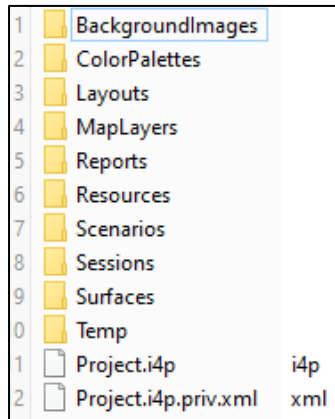

## 4.5 MODEL-RELATED SPATIAL DATA

The Stormwater Division encourages applicants to update existing GIS data and/or create new GIS data as needed to support stormwater design. Provided GIS data should be set up such that data are organized and readily discernable. Applicants are advised that ICPR4 can import model data from GIS data provided that the GIS data follow Streamline Technologies’ required database schemas. Because many SWFWMD efforts rely on ICPR4 and data developed in accordance with the SWFWMD Geographic Watershed Information System (GWIS) geodatabase schema, tools are also available from Streamline Technologies to migrate data from GWIS geodatabases to ICPR4.

If CAD files are provided for model-related spatial data, each file should be set up such that data are organized and readily discernable. For example, separate CAD files should be provided for existing drainage conditions, revised existing conditions, and each proposed condition. Within each file, a unique layer must be provided for each model element type such as basins, nodes, pipes, drop structures, weirs, channels, cross-sections, etc. Additional layers should be kept to the minimum required to display information. All information must be geo-referenced. CAD files should also include geo-referenced graphics such as the proposed grading and drainage plan on a separate layer. Since the County maintains watershed model spatial data in GIS, CAD information must be provided in a format that is readily importable to GIS. CAD file attributes should therefore be developed so that no information is lost when imported to GIS. Failure to deliver CAD information per this guidance will result in extended review time and may require resubmittal.

### 4.5.1 MODEL FEATURE DATA

**Naming of model feature data must be consistent between model-related spatial data, stormwater models, supporting calculations, maps, and drawings.** Names

should be case sensitive and be distinguishable by unique alphanumeric characters. Table 4.2 summarizes requirements for spatial representations (GIS or CAD) of model feature data that must be provided when a stormwater model is used.

**Table 4.2 Summary of Feature Data Requirements**

Feature Type	Feature Data Requirements
Basin	<ul style="list-style-type: none"> <li>▪ Basins are polygons and represent the modeled runoff-response area.</li> <li>▪ No overlapping polygons are allowed.</li> <li>▪ No gaps between polygons are allowed.</li> <li>▪ Exact numerical match between number of polygons and number of modeled basins, e.g., no “sliver polygons.”</li> <li>▪ Attribute table must include name and group name exactly as used in ICPR.</li> <li>▪ Attribute table must include basin area to the 0.001 acre.</li> <li>▪ Exact numerical match between attributed basin area and modeled basin area.</li> <li>▪ No net change in watershed area is allowed without approval of County staff.</li> <li>▪ Attribute table must include revision type: existing, addition, modification, deletion.</li> </ul>
Node	<ul style="list-style-type: none"> <li>▪ Nodes are point locations and must be located at the termination point of links.</li> <li>▪ Typically, one node per basin and in the low-spot of the storage area.</li> <li>▪ Attribute table must include name and group name exactly as used in ICPR.</li> <li>▪ Attribute table must include revision type: existing, addition, modification, deletion.</li> </ul>
Link	<ul style="list-style-type: none"> <li>▪ Links are polylines and should terminate at node locations (from-node and to-node).</li> <li>▪ Links should be digitized upstream-to-downstream to reflect flow direction (from-node to to-node).</li> <li>▪ Link types include: pipe, drop structure, channel, weir, and rating curve.</li> <li>▪ Links should be digitized to match the real-world flow path as much as practical.</li> <li>▪ Typically, digitized links closely follow surface (contours) and sub-surface (pipes) drainage features.</li> <li>▪ Attribute table must include revision type: existing, addition, modification, deletion.</li> </ul>
Cross-section	<ul style="list-style-type: none"> <li>▪ Cross-sections are polylines and should be digitized to match the physical location of the cross-section, which must be determine by the best available topographic information.</li> <li>▪ Cross-sections should be digitized from left to right in the downstream direction and from endpoint to endpoint. For example, from left top of bank to right top of bank.</li> <li>▪ Attribute table must include revision type: existing, addition, modification, deletion.</li> </ul>

Feature Type	Feature Data Requirements
Flow Path	<ul style="list-style-type: none"> <li>▪ Flow paths are polylines representing the hydrologically most-distant flow path for time-of-concentration calculations.</li> <li>▪ Flow paths must be segmented to show sheet flow, shallow concentrated flow, and channelized flow.</li> <li>▪ Flow paths must cross surface contours at a perpendicular angle.</li> </ul>
Floodplain	<ul style="list-style-type: none"> <li>▪ Floodplains are polygons representing inundated area at peak-model-stage.</li> <li>▪ Floodplains are required for existing, revised existing, and proposed conditions and all staff-requested design storms.</li> <li>▪ At a minimum, floodplains are required for the 100-year 24-hour design storm.</li> </ul>

#### 4.5.2 TOPOGRAPHIC INFORMATION

Topographic information is typically provided as contours or a digital terrain model, which is a three-dimensional model that represents the ground surface. Contours should be generated at a maximum of 1-foot intervals to represent on site topography. Digital terrain models should be sufficiently detailed such that 1-foot contours can be developed from the model.

Applicant submittals must include topographic information for existing conditions, revised existing conditions, and proposed conditions.

# CHAPTER 3

## TECHNICAL GUIDANCE

### CHAPTER 3: TECHNICAL GUIDANCE

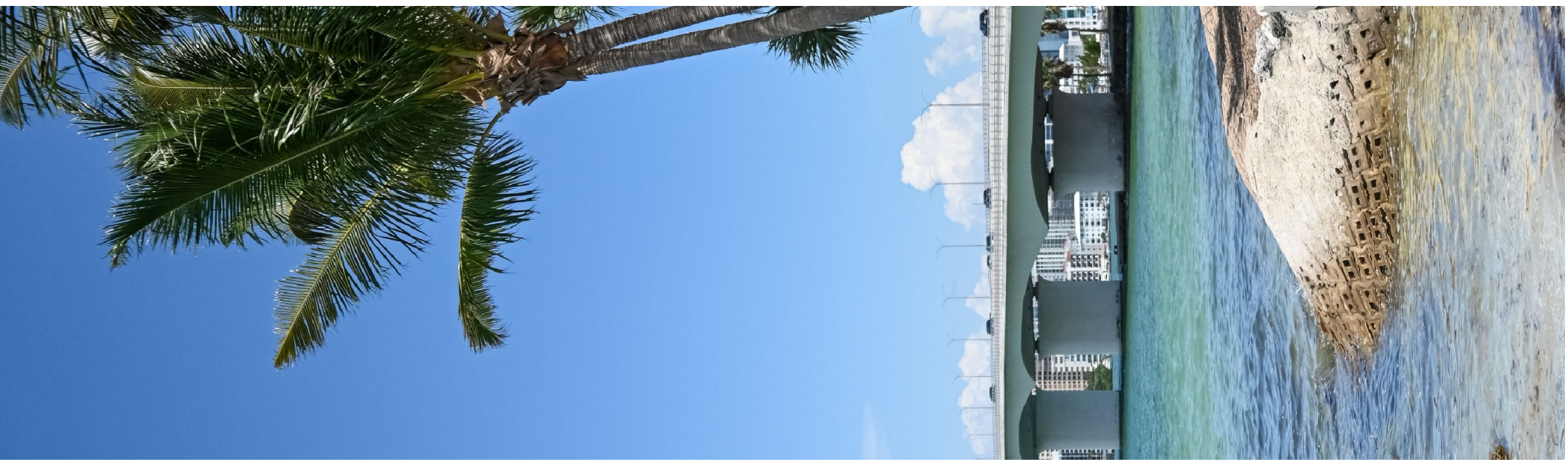

## 5 RATIONAL METHOD

Per UDC Article 13, Section 124-252 (a)(1)a., the Rational Method (RM) is applicable for sites of 10 acres or less. The RM is a simplistic hydrologic approach to estimate the peak discharge for stormwater design and analysis. The applicant will use a RM-based approach to establish existing and proposed stormwater conditions. Compliance is then demonstrated by comparing hydrologic and hydraulic results from each condition to meet presumptive flow criteria (pre-development peak discharge is greater than or equal to post-development peak discharge).

The RM uses an empirical linear equation to predict discharge and is a generally accepted engineering approach for small watershed analysis in Florida. The RM equation to determine peak discharge is simply described as:

$$Q = CiA$$

- where:
- $Q$  = peak discharge flow rate (cubic feet per second [cfs]).
  - $C$  = runoff-response coefficient.
  - $i$  = rainfall intensity (inches/hour).
  - $A$  = contributing watershed area (acre).

The RM is based on the following assumptions:

- Under a constant rainfall intensity, maximum discharge will occur at the watershed outfall when the entire watershed begins contributing runoff.
- Watershed time of concentration is equal to the minimum duration of peak rainfall to generate peak discharge.
- Watershed time of concentration equals the period necessary to determine average rainfall intensity.
- Runoff-response characteristics are independent from rainfall intensity or depth.

### 5.1 DESIGN APPROACH DESCRIPTION

The RM is a hydrologic calculation and will be used to determine peak flows reaching stormwater management system elements and site discharge locations if no stormwater management system is present in existing conditions. RM derived peak flows are in turn used as inflow for hydraulic calculations. Hydraulic calculations, such as sizing stormwater management system conveyance and attenuation features, must ensure continuity of flow and account for hydraulic losses and tailwater conditions.

For existing conditions, on-site information is based on site survey. For proposed conditions, on-site information is based on the applicant's designed stormwater management system. On-site hydrologic and hydraulic calculations must consider site grading, site paving, hydraulic structures, and stormwater management facilities. Off-site tailwater conditions must be based on a County Basin Model or Stormwater Division approved alternative information. At a minimum, provided hydrologic and hydraulic calculations must meet the following criteria:

- Hydrologic calculations must be based on the RM.
- Hydraulic calculations must be based on a conservation of energy approach and must consider hydraulic losses and tailwater conditions.

- An existing and proposed condition peak discharge must be determined for each discharge location from the project site. Discharge locations must maintain historic drainage patterns and inflow/outflow discharge points. Proposed condition peak discharge must not exceed existing condition peak discharge for each discharge point.
- The land development area and any contributing off-site areas must be included in existing and proposed the contributing areas. The existing and proposed contributing areas must be equal to ensure complete accounting of the hydrologic runoff-response.
- Off-site tailwater conditions must be derived from a County Basin Model or Stormwater Division approved alternative information.
- All major stormwater management system design elements must be clearly identified and supported by accompanying documentation in the submittal.

Stormwater management systems typically consist of stormwater inlets, pipes, and ponds. Typically, stormwater ponds are designed prior to stormwater inlets and stormwater inlets are designed prior to stormwater pipes. However, stormwater management system design, hydrologic, and hydraulic calculations often require an iterative approach to ensure design criteria are met.

Stormwater management systems must include compensating floodplain storage volume if development is proposed within the 100-year floodplain. Compensating volume must equal or exceed available storage volume removed from the 100-year floodplain. Compensating volume must be cup-for-cup and consider volume loss between the seasonal high-water elevation and base flood elevation.

The proposed stormwater management system must be designed for long life, low cost, and ease of maintenance. The system must also meet design criteria provided in this Manual (Section 3) and the UDC.

### 5.1.1 HYDROLOGIC CALCULATIONS

The results of hydrologic calculations establish the inflow for hydraulic elements of the stormwater management system or off-site discharge when no hydraulic elements are present. Applicants should generally follow the procedures below for hydrologic calculations.

- Delineate on-site and off-site contributing areas.
- Generate a schematic of the existing (if any) and proposed stormwater management system.
- Delineate the contributing area for each stormwater inlet, pipe segment, and pond.
- Determine the RM C Value for each contributing area (Section 5.2.1).
- Determine the time of concentration for each contributing area (Section 5.2.2).
- Determine the design rainfall intensity for each contributing area (Section 5.2.3).
- Determine peak flow for each contributing area using the RM.

### 5.1.2 HYDRAULIC CALCULATIONS

The results of hydraulic calculations are used to demonstrate compliance with stormwater design criteria for proposed conditions or establish allowable discharge from existing conditions. The approach to hydraulic calculations varies by the design element and is generally described below for common design elements.

### **Stormwater Pipes and Inlets** (Section 5.3)

- Inlet selection and placement should proceed upstream-to-downstream, with inlets located and sized to capture peak runoff from the contributing area.
- Pipe selection and placement should proceed downstream-to-upstream from outlet to inlet to inlet and so on. Pipe size can be estimated using the continuity equation and Manning's equation assuming full pipe flow to convey design inflow.
- Final design must ensure all stormwater pipes and inlets meet Sarasota County level-of-service criteria (UDC Article 18, Appendix C14).
- Final design must be based on conservation of energy and account for all upstream inflows, hydraulic losses for the pipe segment, and tailwater conditions. This is often an iterative approach which is best completed downstream-to-upstream.
- Off-site tailwater conditions are typically established from a County Basin Model or Stormwater Division approved alternative information.
- On-site tailwater conditions are typically established by design high-water elevations from stormwater ponds for the 10-year, 25-year, and 100-year design storms.

### **Stormwater Ponds** (Section 5.4)

- Selection and placement should occur coincident with layout of land development. Preliminary pond siting is often the first element of a stormwater design.
- Final design volume must be based on a Modified-Rational Method (Modified-RM) approach and account for all contributing area to the pond.
- Outfall structures must be sized such that pond peak discharge is maintained at or below the allowable discharge rate.
- Pond discharge of treatment volume must meet County and SWFWMD pond recovery requirements.

#### **5.1.3 DEMONSTRATED COMPLIANCE**

Calculation results will be used to demonstrate compliance with County and SWFWMD criteria as established in Section 3 of this Manual. In short:

- Existing condition results will establish maximum allowable off-site discharge rate at each off-site discharge location.
- The proposed condition results must clearly demonstrate the maximum proposed off-site discharge rate at each off-site discharge location.
- The proposed condition results must clearly demonstrate inlet and pipe compliance with level-of-service criteria.
- The proposed condition results must clearly demonstrate proposed peak stage(s) adjacent to habitable structures. No flooding of habitable structures is allowed.
- The proposed condition results must clearly account for all proposed off-site discharge locations. No off-site discharge is allowed except through proposed outfalls, which must be located to maintain historic drainage flow patterns and inflow/outflow discharge points.
- The proposed condition results must clearly demonstrate the stormwater management systems ability to convey and attenuate the 10-year, 25-year, and 100-year design storms. Ponds must attenuate the 100-year design storm with allowance for 0.5 foot of freeboard.
- The proposed condition results must clearly demonstrate no adverse off-site impacts by meeting presumptive criteria, which are based on existing condition peak discharge rate and available 100-year floodplain volume. The maximum proposed off-site discharge rate

cannot exceed the allowable off-site discharge rate at each off-site discharge location. The available 100-year floodplain volume in the existing condition must be equally provided in the proposed condition.

- The proposed condition results must clearly demonstrate proposed treatment volume meets Sarasota County and SWFWMD treatment volume requirements.
- The proposed condition results must clearly demonstrate proposed discharge of treatment volume meets SWFWMD pond recovery requirements.

Applicants are reminded that all submittals requiring Stormwater Division review must include the items below to demonstrate compliance as described in Section 2.4 of this Manual.

- Stormwater Management Plan. Proposed easements must be shown in construction plan drawings and meet County criteria (UDC Article 18, Appendix C13a, C13b, C13c, and C29).
- Subdivision Plat and Site Development Plan Stormwater Review Checklist (UDC Article 18, Appendix C24).
- Construction Plan Stormwater Review Checklist (UDC Article 18, Appendix C25).
- Construction Plan Stormwater Design Summary (UDC Article 18, Appendix C26a) signed-and-sealed by the Engineer of Record.
- Construction Plan Stormwater Design Summary for Net Improvement (UDC Article 18, Appendix C26b) signed-and-sealed by the Engineer of Record, if warranted.

The Stormwater Division may require demonstration of compliance with additional criteria as site conditions warrant. The Stormwater Division **strongly recommends applicants request a stormwater methodology meeting** to establish stormwater criteria required and how compliance is best demonstrated within a submittal.

## 5.2 DETERMINING PEAK RUNOFF RATE

The RM will be used for hydrologic calculations to determine peak runoff rate from contributing areas. Contributing areas must be appropriately delineated for each calculation. Determination of rational C Values, time of concentration, and rainfall intensity is discussed further below.

### 5.2.1 DEVELOPMENT OF RATIONAL C VALUE

The higher the density of the proposed development, the higher weighted area C Value is expected. Although the development of appropriate C Values for a site requires engineering judgment, larger open areas with minimal slope and dense vegetative cover (such as a large, flat, grassy field) generally have the lowest C Values. Open areas with significant slopes and limited vegetative cover have the higher C Values. Impervious areas have the highest C Values.

Table 5.1 presents the Stormwater Division's recommended values to generate an area-weighted-average C Value for the contributing area. The presented values are limited and require explicit accounting of impervious and pervious areas to apply the RM. Using the table as guidance, residential land developments are typically represented by a weighted C Value of 0.50~0.75. The Stormwater Division will approve C Values not presented here with accompanying documentation, such as manufacturer or literature values.



**Table 5.1 Summary of Recommended Runoff Coefficients**

Land Cover Description	Runoff Coefficient (C value)
Water Features (wet pond, canal, natural waterbodies, etc.)	1.00
Heavily Improved Area or Impervious Area (wetland, roof, street, sidewalk, paved driveway, paved parking lot, parking lot, etc.)	0.95
Moderately Improved Area (compacted gravel or shell driveway, compacted gravel or shell parking areas, etc.)	0.75
Lightly Improved Area or Clayey Pervious Area (loose gravel or shell landscaping, open areas with low permeability soils, etc.)	0.55
Sandy Pervious Area (open areas with high permeability soils, mulch, etc.)	0.20

### 5.2.2 ESTIMATING TIME OF CONCENTRATION

Several methods are available in the literature to estimate time of concentration ( $T_c$ ) for overland flow and they are too numerous to list here in full. Channelized flow or pipe flow travel times are commonly estimated using Manning’s equation. The County has adopted the Natural Resources Conservation Service (NRCS) *Technical Release 55* (TR-55) method for development of  $T_c$  for County Basin Models. For consistency, applicants shall use the NRCS TR-55 methodology with a minimum  $T_c$  of 10 minutes for hydrologic design.

Applicants must estimate  $T_c$  for each proposed outfall and for each inlet contributing area to determine rainfall intensity as described in Section 5.3. Estimated times must be developed using a segment velocity approach that explicitly considers shallow overland flow, concentrated overland flow, channelized flow, and pipe flow segment times as warranted. The Stormwater Division will make final the determination if the estimated  $T_c$  is reasonable.

Hydrologic flow paths used to represent the hydrologically most distant flow path for  $T_c$  calculations must be included in applicant submittals, typically as a map. The Stormwater Division will review all calculated travel times and accompanying hydrologic flow paths for reasonableness. Attachment 6 includes a template for presenting  $T_c$  calculation results.

### 5.2.3 DETERMINING RAINFALL INTENSITY

The County regulates stormwater discharge for the 10-year, 25-year, and 100-year design storms. Unlike design storm modeling, which is based on design storm depths and unit hydrographs, the RM is based directly on rainfall intensity. Applicants must determine rainfall intensity using the Florida Department of Transportation (FDOT) intensity-duration-frequency (IDF) curves for Zone 6. The Zone 6 IDF curves and additional information on the provided regression equation is in Attachment 7.

## 5.3 SIZING STORMWATER CONVEYANCE FEATURES

Typically, the proposed stormwater management system conveyance includes stormwater inlets and pipes as conveyance features. If other stormwater conveyance features are included in the design, the same principles discussed here should be used to size those features as well. Applicants are directed to FDOT’s *Drainage Design Guide* for additional information on stormwater calculations using the RM for various conveyance features.

### 5.3.1 STORMWATER INLETS

Stormwater inlets must be designed such that the proposed stormwater management system fully captures the design flows. For roadside inlets, roadway spread, bypass flow, and roadway inundation depth are commonly determined by spreadsheet analysis. In general, this type of spreadsheet analysis is based on inlet capture rate, which is typically determined from nomographs developed for standard inlet types or provided by manufacturers. Most applicants use FDOT standard type inlets and more information about design capture rates for these inlets is provided in FDOT's *Drainage Design Guide*. Applicants are also directed to Federal Highway Administration's *Urban Drainage Design Manual* (aka HEC-22) for additional guidance regarding stormwater inlet capture rates.

Inlet analysis must compare design inlet capture rate and RM derived peak flows for the inlet's contributing area to determine gutter spread and bypass flow. Bypass flow is not allowed for sag inlets. Applicants must calculate the roadway inundation depth at each inlet based on the gutter spread and roadway cross-slope.

### 5.3.2 STORMWATER PIPES

Applicants must use the RM to determine peak flow for the contributing area to each pipe segment. For most stormwater management systems, pipe segment peak flow will be less than the sum of peak flows from all upstream inlets (due to travel time within the system). Tc calculations and corresponding RM peak flows should reflect this difference, whereas simply summarizing upstream inlet peak flow will result in potentially overly conservative estimates of pipe flow.

Applicants must determine pipe size, geometry, and slope for each pipe segment using a conservation of energy approach, which accounts for local energy losses and tailwater conditions. This approach is typically an iterative process and applicants are directed to FDOT's *Drainage Design Guide* and Federal Highway Administration's *Urban Drainage Design Manual* (aka HEC-22) for additional guidance regarding a step-wise conservation of energy approach to pipe design. The stormwater pipe system hydraulic grade line determined through the step-wise approach must meet County level-of-service standards. To demonstrate compliance with level-of-service standards, applicants must summarize the hydraulic grade line elevation at each stormwater pipe junction and report proposed and allowable flooding depths. Attachment 8 includes an example level-of-service summary table that includes internal pipe calculations using the RM.

Applicants may use Manning’s equation to estimate a minimum pipe size for full pipe flow to aid in the design process. Since peak flow occurs during partially full pipe flow, Manning’s equation will typically yield a conservative estimate of minimum pipe size required. Manning’s equation is presented below, rearranged to solve for the diameter of a round pipe.

$$D = \left( \frac{2.16Qn}{\sqrt{S}} \right)^{3/8}$$

where:  $D$  = pipe diameter (feet).

$Q$  = design flow rate (cfs).

$n$  = Manning’s roughness coefficient.

$S$  = design slope (feet/feet).

## 5.4 SIZING ATTENUATION PONDS

The required volume for attenuation ponds should be determined using a Modified-RM approach. Determining the required pond outfall structure is typically an iterative process associated with determining the recovery rate for the pond.

### 5.4.1 POND VOLUME

Design pond volume should be determined using a Modified-RM approach. Numerous examples are available in the literature of Modified-RM approaches. Most iteratively solve the maximum volume difference between inflow and outflow hydrographs for different storm (intensity) durations. The calculated volume is then increased by a factor of safety to estimate the pond storage volume requirement to fully attenuate peak flows, since storage volumes are known to be underestimated by most Modified-RM approaches when compared to more physically based approaches and real-world conditions due to the simplistic shapes of the estimated inflow and outflow hydrographs. The peak flow for the inflow hydrograph is determined from the RM.

The Stormwater Division has developed a spreadsheet that uses a Modified-RM approach to determine pond volume (Attachment 9). The Stormwater Division’s approach assumes a trapezoidal-shaped inflow hydrograph, with the first inflection point occurring at the pond’s  $T_c$ , the second inflection point occurring at the end of the storm duration, peak flow occurring from time of concentration to end of storm duration, and the duration of inflow equaling the  $T_c$  plus the storm duration. Meanwhile, the outflow hydrograph is assumed to be a constant flow at the maximum allowable discharge rate and outflow does not begin until inflow  $T_c$ . The difference in volume (inflow minus outflow) is calculated at 5-minute intervals for storm durations between 5 minutes and 300 minutes. The rainfall intensity is determined using the equation in Section 5.2. The maximum volume difference for all calculated durations is increased by a 20-percent factor of safety to estimate the required storage volume.

An example similar to the Stormwater Division’s spreadsheet is provided in UDC Article 18, Appendix C15. The difference between the Stormwater Division’s spreadsheet as described above and Appendix C15 is that Appendix C15 references that outflow should not be considered until the first 1 inch of runoff or first 1 inch of rainfall has been retained on site as dictated by the design treatment method. The Stormwater Division’s spreadsheet assumes this time occurs near the  $T_c$  for inflow.

#### 5.4.2 POND OUTFALL

Typically, pond outflow is controlled by one or more vertical weirs in the side of the outfall control structure for a wet pond and/or vertical infiltration for a dry pond. Outflow of the pond control volume should meet SWFWMD pond recovery requirements and maintain flows at or below the allowable discharge rate.

### 5.5 APPROACH SPECIFIC SUBMITTAL REQUIREMENTS

In addition to the submittal requirements defined in Section 2.4, the following must be provided with submittals when the RM is used for hydrologic design:

- Hydrologic and hydraulic calculations to support stormwater inlet, pipe, and pond outfall design. Including, but not limited to, time of concentration and internal pipe calculations.
- Hydraulic attenuation calculations to size stormwater ponds.
- Stormwater treatment calculations to determine treatment volume and recovery time.
- Summary tables to demonstrate compliance with County level-of-service criteria.
- Volumetric calculations to demonstrate cup-for-cup floodplain compensation, including cross-sections.

All submittals must meet the standards established in Section 4.

## 6 HYDROGRAPH METHOD

Per UDC Article 13, Section 124-252 (a)(1)a., the Hydrograph Method is applicable for project sites greater than 10 acres and less than 35 acres of total area with less than 8 acres of impervious area. The Hydrograph Method requires computing rainfall-derived runoff hydrographs for the land development project site and routing the runoff hydrographs through hydraulic features to establish on-site hydrologic and hydraulic conditions for stormwater design and analysis. Applicants will develop stormwater models to route the hydrographs under existing and proposed conditions. Compliance is then demonstrated by comparing results from each condition to meet presumptive flow criteria (pre-development peak discharge is greater than or equal to post-development peak discharge).

The Stormwater Division recommends applicants use stormwater models developed in Interconnected Channel and Pond Routing Model Version 4 (ICPR4) for this method. Technical guidance provided in this section has generally been developed for ICPR4 but can be applied to any stormwater modeling software. When this Manual was composed, the most recent release of ICPR4 was version 4.07.08, released on February 9, 2021.

ICPR3 was discontinued in 2016 and is no longer sold or supported by Streamline Technologies, Inc. More detailed discussion on the differences between ICPR3 and ICPR4 are provided in Section 8 of this Manual. Applicants interested in more information about ICPR3-related data needs and modeling approaches are referred to the previous version of this Manual published in 2007. Applicants interested in more information on ICPR4 than provided here are directed to the *ICPR4 Technical Reference* (Streamline Technologies, 2018) and additional materials linked within the ICPR4 help dialog. These ICPR4 materials are collectively referred to as *ICPR4 support documentation* throughout this Manual.

### 6.1 DESIGN APPROACH DESCRIPTION

Within ICPR4, hydrologic and hydraulic input data and simulation controls are stored as unique scenarios (Section 8.2). Therefore, applicants can complete hydrologic and hydraulic calculations for existing conditions and proposed conditions within a single ICPR4 model using two scenarios or create two ICPR4 models each with one scenario. The computational results are the same; however, **the Stormwater Division strongly prefers applicants provide one ICPR4 model with two scenarios.** For simplicity, this Manual considers unique hydrologic and hydraulic calculations for different drainage conditions to be a *model* which is synonymous with an ICPR4 scenario.

The applicant will develop a model to establish the existing condition and then use the existing condition model data as base data to develop a proposed condition model. For existing conditions, on-site model elements are typically based on site survey while off-site model elements and boundary conditions must be based on County Basin Models. For proposed conditions, applicants will design a stormwater management system and revise on-site model elements as necessary to incorporate the design elements including site grading, site paving, hydraulic structures, and stormwater management facilities. In general, the existing and proposed condition models should be developed as discussed in this Manual, ICPR4 support documentation provided by Streamline Technologies, and standard modeling practices.

At a minimum, the developed stormwater models must meet the following criteria:

- The latest ICPR4 version should be used to develop the stormwater models.
- An existing condition model must be developed.
- A proposed condition model must be developed by revision of the existing condition model.
- The entire proposed site and any contributing off-site areas must be included in the modeled areas.
- Boundary conditions must be derived from County Basin Models where available or other data approved by the Stormwater Division where not available.
- All major stormwater design elements must be included in the proposed model.
- Model differences between the existing and proposed condition must be clearly identified and supported by accompanying documentation in the submittal.
- Model elements and parameters must be developed following standard engineering practices and this Manual.
- Model simulations must be stable and produce reasonable, repeatable results.

Stormwater management systems typically consist of stormwater inlets, pipes, and ponds. Typically, stormwater ponds are designed prior to stormwater inlets and stormwater inlets are designed prior to stormwater pipes. However, stormwater management system design, hydrologic, and hydraulic calculations often require an iterative approach to ensure design criteria are met. Development of a model allows for hydrologic and hydraulic calculations for elements of the proposed stormwater management system to occur simultaneously.

Stormwater management systems must include compensating floodplain storage volume if development is proposed within the 100-year floodplain. Compensating volume must equal or exceed available storage volume removed from the 100-year floodplain. Compensating volume must be cup-for-cup and consider volume loss between the seasonal high-water elevation and base flood elevation.

The proposed stormwater management system must be designed for long life, low cost, and ease of maintenance. The system must also meet design criteria provided in this Manual (Section 3) and the UDC.

### 6.1.1 HYDROLOGIC CALCULATIONS

Unlike the Rational Method described in Section 5, which relies on simplistic hydrograph development, the Hydrograph Method couples rainfall depth and a synthetic rainfall distribution to generate a design storm. The applicant will develop the 10-year, 25-year, and 100-year design storms using the appropriate 24-hour rainfall depth for the project site, which must be determined in accordance with current Southwest Florida Water Management District (SWFWMD) guidance. When this Manual was developed, SWFWMD required design storms to be generated based on District generated rainfall maps to determine design storm rainfall depth and the Florida Modified Type II synthetic rainfall distribution to develop the design storm hydrograph. Applicants should review the most recent SWFWMD guidance for Environmental Resource Permitting, provided at the time of this Manual in *Applicant's Handbook Volume II*.

The design storm hydrograph will be applied to unique contributing areas, which are represented in the model by basins. Applicants will also assign runoff parameters and a unit hydrograph to each basin, which will in turn be used to determine the runoff-response from each basin. Runoff-response hydrographs will then be routed through hydraulic features.

Hydrologic simulation controls dictate the numeric calculations. While hydrologic calculations will be performed by the model, applicants must develop supporting data for the model inputs as needed. Applicants should generally follow the procedures below to develop model input data for hydrologic calculations of each modeled drainage condition (Section 6.3).

- Delineate off-site contributing areas (if any).
- Delineate the contributing area (basin) for each stormwater management system element included in the stormwater model.
- Determine the total area and impervious area for each basin.
- Determine the time of concentration for each basin.
- Determine the curve number for each basin.
- Determine the peaking factor and unit hydrograph for each basin.
- Determine the loading node for each basin.

### 6.1.2 HYDRAULIC CALCULATIONS

Similar to the Rational Method described in Section 5, applicants will identify significant hydraulic features for routing calculations. These features will be included in the hydraulic network. Nodes represent locations for model-stage prediction, such as stormwater ponds, inlet locations, storm pipe junctions, etc. Links represent conveyance features such as pipes, channels, and weirs. Applicants will develop the hydraulic network and parameters based on known or proposed information. For example, the existing condition parameters should be based on a site survey. The proposed condition hydraulic network and parameters must be developed to match the proposed stormwater design, including submitted plan drawings and supporting calculations. Hydraulic simulation controls dictate the numeric calculations. While hydraulic calculations will be performed by the stormwater model, applicants must develop supporting data for the model inputs as needed. Applicants should generally follow the procedures below to develop model input data for hydraulic calculations of each modeled drainage condition (Section 6.4).

- Develop the hydraulic network.
- Determine the stage-area relationship for each node.
- Determine the initial condition for each node based on hydraulic conveyance connections and tailwater conditions.
- Determine the invert elevation, geometry, dimensions, and roughness (material) of each conveyance.
- Determine hydraulic losses associated with each conveyance.
- Determine necessary overland flow connection locations.

### 6.1.3 DEMONSTRATED COMPLIANCE

Model results will be used to demonstrate compliance with County and Southwest Florida Water Management District (SWFWMD) criteria as established in Section 3 of this Manual. In short:

- The existing condition model results will establish the maximum allowable off-site discharge rate to each boundary node.
- The proposed condition model results must clearly demonstrate the maximum proposed off-site discharge rate to each boundary node.

- The proposed condition model results must clearly demonstrate proposed peak stage adjacent to habitable structures. No flooding of habitable structures is allowed.
- The proposed condition model results must clearly account for all proposed off-site discharge locations. No off-site discharge is allowed except through the proposed stormwater management system.
- The proposed condition model results must clearly demonstrate the stormwater management systems ability to convey and attenuate the 10-year, 25-year, and 100-year design storms. Ponds must attenuate the 100-year design storm with allowance for 0.5 foot of freeboard.
- The proposed condition results must clearly demonstrate no adverse off-site impacts by meeting presumptive criteria, which are based on existing condition peak discharge rate and available 100-year floodplain volume. The maximum proposed off-site discharge rate cannot exceed the allowable off-site discharge rate to each boundary node. The available 100-year floodplain volume in the existing condition must be equally provided in the proposed condition.
- The proposed condition results must clearly demonstrate proposed treatment volume meets Sarasota County and SWFWMD treatment volume requirements.
- The proposed condition results must clearly demonstrate proposed discharge of treatment volume meets SWFWMD pond recovery requirements.

The Stormwater Division requires a proposed condition modeling approach that does not include surface storage outside the proposed stormwater management system to easily demonstrate that the level-of-service requirements are met. Applicants should summarize the model results in a table or tables to demonstrate compliance with level-of-service criteria. Inlet level-of-service compliance is typically demonstrated separately from ICPR4 results. Applicants must demonstrate that stormwater inlets and pipes meet the County's level-of-service criteria (Section 3.3).

The Stormwater Division has developed automated tools to aid applicants in demonstrating compliance. The County's ICPR4 Input Data Comparator returns a summary of model changes between two ICPR4 models. The Comparator should be used to document changes made from existing conditions to revised existing conditions or proposed conditions. The County's ICPR4 Input Data QC Tool performs quality control checks on model input data based on standard modeling practice. The Tool should be used as part of the applicant's quality control process but should not be used in lieu of other quality control practices typical to stormwater model development.

Applicants are reminded that all submittals requiring Stormwater Division review must include the items below to demonstrate compliance as described in Section 2.4 of this Manual.

- Stormwater Management Plan. Proposed easements must be shown in construction plan drawings and meet County criteria (UDC Article 18, Appendix C13a, C13b, C13c, and C29).
- Subdivision Plat and Site Development Plan Stormwater Review Checklist (UDC Article 18, Appendix C24).
- Construction Plan Stormwater Review Checklist (UDC Article 18, Appendix C25).
- Construction Plan Stormwater Design Summary (UDC Article 18, Appendix C26a) signed-and-sealed by the Engineer of Record.
- Construction Plan Stormwater Design Summary for Net Improvement (UDC Article 18, Appendix C26b) signed-and-sealed by the Engineer of Record, if warranted.



The Stormwater Division may require demonstration of compliance with additional criteria as site conditions warrant. The Stormwater Division **strongly recommends applicants request a stormwater methodology meeting** to establish stormwater criteria required and how compliance is best demonstrated within a submittal.

## 6.2 MODEL DEVELOPMENT

A model schematic consists of basins representing unique runoff-response areas that are integrated with a hydraulic network comprised of nodes and links representing hydraulic storage and conveyance elements, respectively. The model schematic forms the skeleton of the model. The model is fully formed by assignment of hydrologic parameters, hydraulic parameters, and simulation controls. In ICPR4, model elements typically include basins, nodes, links, and cross-sections.

The volume and timing of stormwater runoff from the landscape are referred to as the runoff-response, and areas where the runoff-response discharges to a common stormwater feature should be represented in the model schematic by a unique drainage basin. The stormwater model calculates the runoff-response for each basin and loads runoff-response hydrographs to assigned nodes within the hydraulic network. Runoff-response hydrographs are calculated by the model based on basins and hydrologic parameters (Section 6.3).

These runoff-response inflows are routed through the hydraulic network. Runoff accumulates at nodes and is conveyed between nodes by links. Links represent known hydraulic features (e.g., bridge, channel, pipe, drop structure, weir) and overland flow connections. Each link connects nodes upstream and downstream of the hydraulic feature or overland connection. Cross-sections are used by model links and typically represent overland flow. Stormwater routing is calculated by the model based on the hydraulic network and hydraulic parameters (Section 6.4). The Stormwater Division requires applicants to use information from County Basin Models for model boundary conditions (Section 6.5), which define the limit of hydraulic calculations.

In ICPR4, the Simulation Manager (Section 6.6) establishes simulations controls, including some universal data inputs, and directs numeric hydrologic and hydraulic calculations.

For well-developed models, basins must be delineated at a scale to appropriately define the runoff-response and load representative node locations within the hydraulic network. The hydraulic network must be defined with sufficient detail to represent physical conditions on-site. At a minimum, the applicant will need to incorporate hydraulic elements of the primary stormwater management system into the existing and proposed condition models. Applicants may explicitly model pipes for secondary conveyance systems (internal pipe calculations) where normal flow is likely to occur or separately perform hydraulic calculations for the secondary conveyance system (Section 8.3).

For this Manual, the primary stormwater management system is defined as hydraulic features that are the controlling features during all the design storms. Primary features typically convey stormwater through the project site or discharge the stormwater from the project site, such as main storm drains for a roadway or pond control structures. The secondary stormwater management system is defined as all other hydraulic features that collect and convey stormwater to the primary system, such as roadway inlets and lateral storm drains, parking lot stormwater inlets and drains, swales, etc.

Proposed conditions model development is often an iterative process during stormwater design. Proposed stormwater elements should be included in the stormwater model and modified as needed during the design process to meet compliance criteria. Model schematics used for stormwater design must be provided with applicant submittals as maps and spatial data. For ICPR4, model schematic should be represented spatially within ICPR4 and proposed condition drawings should be included as background images to support the model schematic.

### 6.3 HYDROLOGIC PARAMETERS

Hydrologic parameters are assigned to model basins and are an important part of the stormwater design process. The Natural Resources Conservation Service (NRCS) *Technical Release 55 (TR-55)* and the *Sarasota County Watersheds Floodplain Model Methodology Report* (Attachment 10) establish the methods that must be used to develop model basin parameters. **The Stormwater Division recommends applicants use the Simple Basin Data approach for hydrologic data input in ICPR4** (Figure 6.1). ICPR4’s Manual Basin Data approach allows users to calculate basin parameters based on data layers and related tables within ICPR4. Applicants are referred to the ICPR4 support documentation for additional details on this approach.

**Figure 6.1 ICPR4 Simple Basin Data GUI**

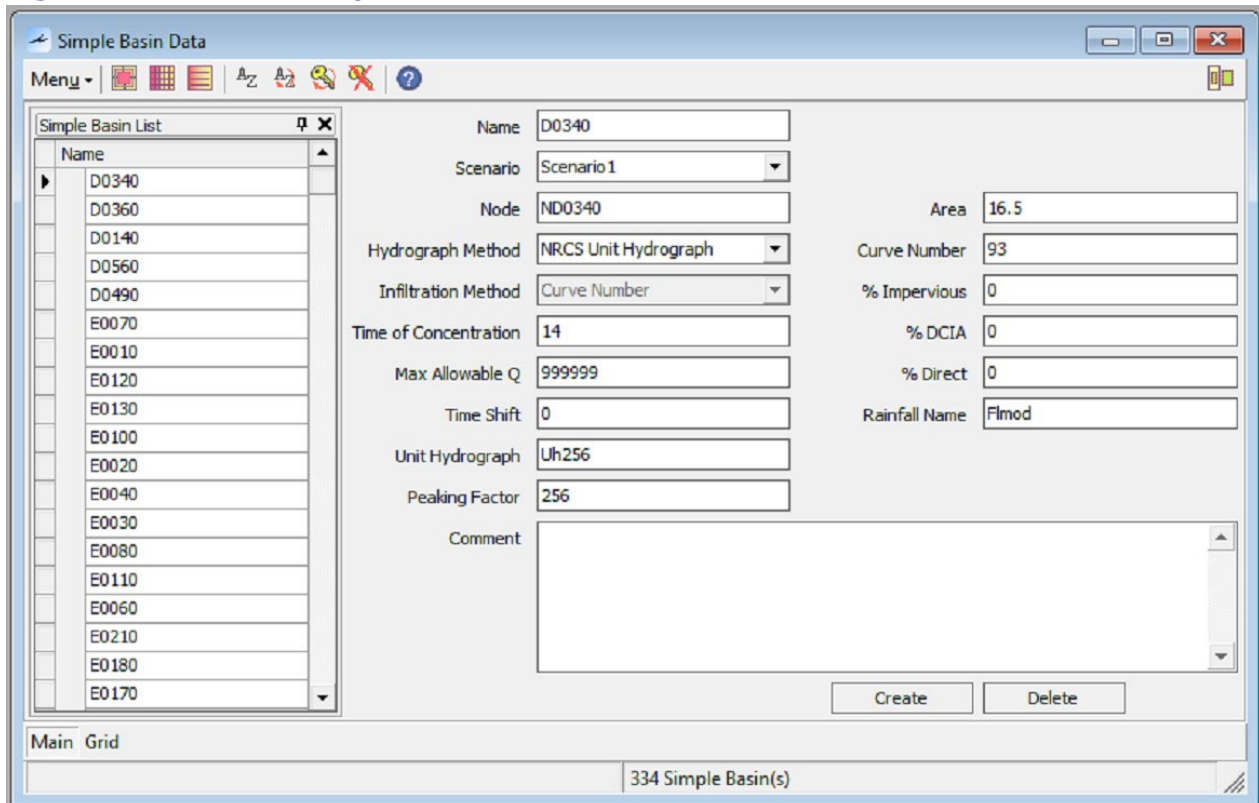

#### 6.3.1 BASIN AREA

Basin area in acres should be determined using the model schematic and calculated in geographical information system (GIS) or computer-aided design (CAD). **The sum of all basin areas must be equal for the existing, revised existing, and proposed conditions.**

### 6.3.2 IMPERVIOUS AREA

Impervious area can be divided into two categories, directly connected impervious area (DCIA) and unconnected impervious area. DCIA is impervious area that is directly connected to the basin discharge point via continuous impervious surface(s) such that DCIA-generated runoff does not flow over pervious surfaces. In contrast, unconnected impervious area is not continuously connected, and therefore generated runoff may flow over pervious surfaces and subsequently infiltrate. DCIA should be directly calculated from a site survey or the proposed design plan drawings and must be explicitly assigned to each basin as a percent. Applicants must provide sufficient documentation of DCIA to validate the model input data.

The Stormwater Division requires applicants submit a spreadsheet or tabulation within a drawing that details planned impervious area. Impervious quantities must be documented by impervious type: roofs and driveways, streets, sidewalks, ponds, wetlands, etc. For Master Stormwater Management Plans, impervious area must be defined by specific areas such as per model basin and provided in the form of a tracking log (or similar) for use during the life of the Master Stormwater Management Plan.

### 6.3.3 CURVE NUMBER

Since DCIA is explicitly assigned as a basin parameter, the basin curve number (CN) must therefore only represent pervious and unconnected impervious areas. The Stormwater Division has developed and tested a simplified CN approach for pervious areas in Sarasota County, which requires CN equal to 78 be used for all pervious areas and CN equal to 98 be used for all unconnected impervious areas. The basin CN is then calculated as the area-weighted average of the pervious and unconnected impervious area. Attachment 10 provides the *Sarasota County Watersheds Floodplain Model Methodology Report* and further discussion of this approach.

### 6.3.4 TIME OF CONCENTRATION

The estimated time of concentration ( $T_c$ ) must be developed using a segment velocity approach that explicitly considers shallow overland flow, concentrated overland flow, channelized flow, and pipe flow segment times as warranted. Section 5.3 provides additional discussion of  $T_c$ . The TR-55 methodology shall be used with a minimum  $T_c$  of 10 minutes. The Stormwater Division will make final determinations on whether estimated time of concentration is reasonable.

Attachment 6 includes a template for providing  $T_c$  calculations. Hydrologic flow paths used to represent the hydrologically most distant flow path for  $T_c$  calculations must be included in applicant submittals, typically as a map. The Stormwater Division will review all calculated travel times and accompanying hydrologic flow paths for reasonableness.

### 6.3.5 UNIT HYDROGRAPHS AND PEAK RATE FACTORS

The NRCS Unit Hydrograph approach must be used. A peaking factor of 100 must be used for basins in an undeveloped condition and a peaking factor of 256 must be used for basins in a developed condition. A mix of developed and undeveloped conditions may exist within the project area. Within ICPR4, the Uh256 unit hydrograph should be used with peaking factor 256, and the Uh100C unit hydrograph should be used with peaking factor 100. Attachment 11 provides additional unit hydrograph information.

Applicants need to receive approval from the Stormwater Division to use peak rate factors and/or unit hydrographs not described above.

## 6.4 HYDRAULIC PARAMETERS

Hydraulic parameters are assigned to model features in the hydraulic network and are an important part of the stormwater design process. The Stormwater Division requires applicants use ICPR4 pipe links (Figure 6.2) to represent pipe flow in storm drains, channel links (Figure 6.3) to represent channel flow in natural or man-made channels and ditches, weir links (Figure 6.5) to represent overland flow or weir flow, and drop structure links to represent features that combine weir and pipe flow such as control structures. Applicants must also establish initial water elevations and stormwater management system surface storage using nodes (Figure 6.4) in ICPR4.

### 6.4.1 DIMENSION AND ELEVATION DATA

Dimension and elevation data for features included the model hydraulic network should be based on site survey for existing conditions and stormwater management system design for proposed conditions. Feature parameters such as feature length, invert elevation(s), geometry, and dimensions must match these data sources. As provided in Section 4, dimension and elevation information should be generated using the following horizontal and vertical coordinate system information:

- State Plane Coordinate System.
- Florida West Zone (Zone 3626 – FIPS 0902).
- North American Datum of 1983 (NAD83) (2011 Adjustment).
- North American Vertical Datum of 1988 (NAVD88) vertical units in US Survey Feet.

Applicants are advised that required coordinate system is based on the best available information and County standards at the time this Manual was developed. County standards may evolve as future vertical and horizontal datums are developed. If elevation information is developed based on a multiple vertical datums, the elevation conversion process should be documented and provided as part of the submittal.

For hydraulic features that require model cross-sections, cross-section locations should be selected to best represent the physical conveyance and be based on survey or design data. For channel links, cross-sections locations should avoid transitional areas such as immediately adjacent to piped conveyance or bends in the channel. For channels of uniform dimensions, such as man-made ditches, one cross-section may be appropriate to represent the upstream and downstream channel section.

Applicants are reminded that feature names must be consistent between model-related spatial data, stormwater models, supporting calculations, maps, and drawings.

### 6.4.2 SOLUTION APPROACHES

Solution approaches for model links should consider available model information, relevant assumptions, and modeling goals. The Stormwater Division recommends the solutions approaches below, which are applicable for the most common modeling scenarios within the County. Applicants are referred to the ICPR4 support documentation for additional details on these approaches.

- Pipes and Channels: The Energy Switch should be set to Energy.
- Weirs: The Weir Type should be set to Broad Crested, Vertical, Sharp Crested, Vertical, or Horizontal as appropriate. The Weir Type should not be set to Paved Road, Vertical or Gravel Road, Vertical.
- Drop Structures: The Energy Switch and Weir Type should follow the guidance for Pipes and Weirs. The Solution should be set to Combined and Increments set to 0, which establishes an interval halving approach. The Solution may be set to Split if velocity predictions are required, but users should review these links for solution stability. A fixed interval approach, such as setting Solution to Combined and Increments to 10, should not be used.

**Figure 6.2 ICPR4 Link Pipe Data GUI**

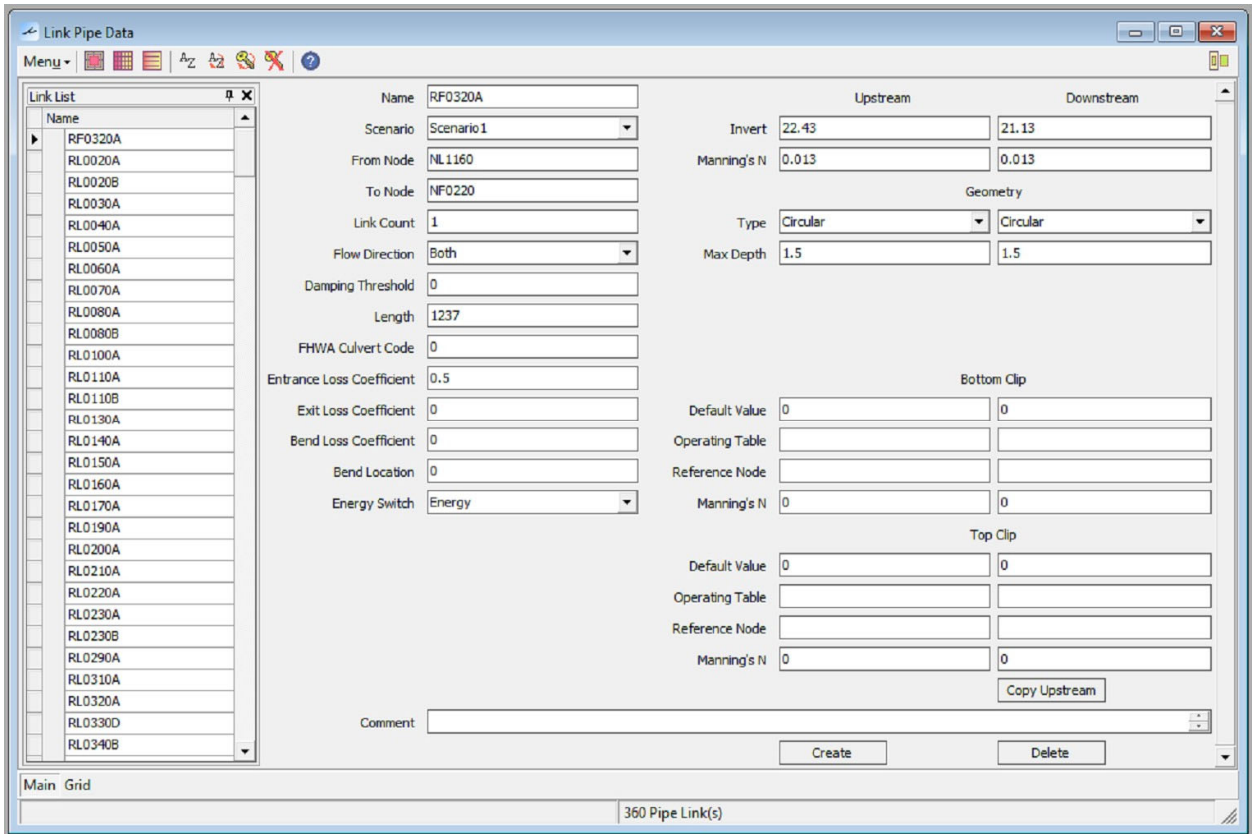

### 6.4.3 MANNING’S COEFFICIENT

Manning’s n is a coefficient that represents hydraulic resistance in Manning’s equation and is used by ICPR4 for pipe, drop structure, and channel links. For links assigned an irregular cross-section, Manning’s n can be assigned to individual station-elevation pairs. Applicants are advised that while it is possible to assign Manning’s n values to station-elevation pairs used for weir cross-sections, Manning’s n is not considered by ICPR4 when calculating weir flow.

Manning’s n is typically assigned to closed conduits based on material and to open channels by comparison to photos of studied systems. Literature values for Manning’s n are summarized in the ICPR4 support documentation and applicants are also directed to the Federal Highway Administration (FHWA) *Hydraulic Design of Highway Culverts* for additional

information. Applicants must be consistent in application of Manning's n values. For example, all concrete pipe should be assigned the same Manning's n value.

#### 6.4.4 LOSS COEFFICIENTS

In general, loss coefficients should be assigned based on the ICPR4 support documentation. Entrance losses should represent the efficiency (or energy loss) of the model element's inlet to smoothly transition flow from upstream. Exit losses should represent the energy loss when flow transitions from the model element downstream. Entrance and exit losses are typically assigned to pipe links and the pipe element of drop structure links. In some cases, entrance and exit losses should also be assigned to channel links. Given the expected level of detail required for proposed condition modeling, bend losses should typically not be necessary. Applicants must adhere to the general guidance provided below:

- All pipe links must be assigned an entrance loss greater than zero based on the most representative FHWA inlet description as described in *Hydraulic Design of Highway Culverts, Third Edition*, Table C-2 (FHWA, 2012).
- All hydraulic links discharging to a pond, lake, wetland, or other large storage area must be assigned an exit loss of 1.0.

Applicants should exercise good engineering judgment when assigning entrance, exit, or bend losses outside of the situations described above. The Stormwater Division will make the final determination on disputed loss coefficients.

**Figure 6.3 ICPR4 Link Channel Data GUI**

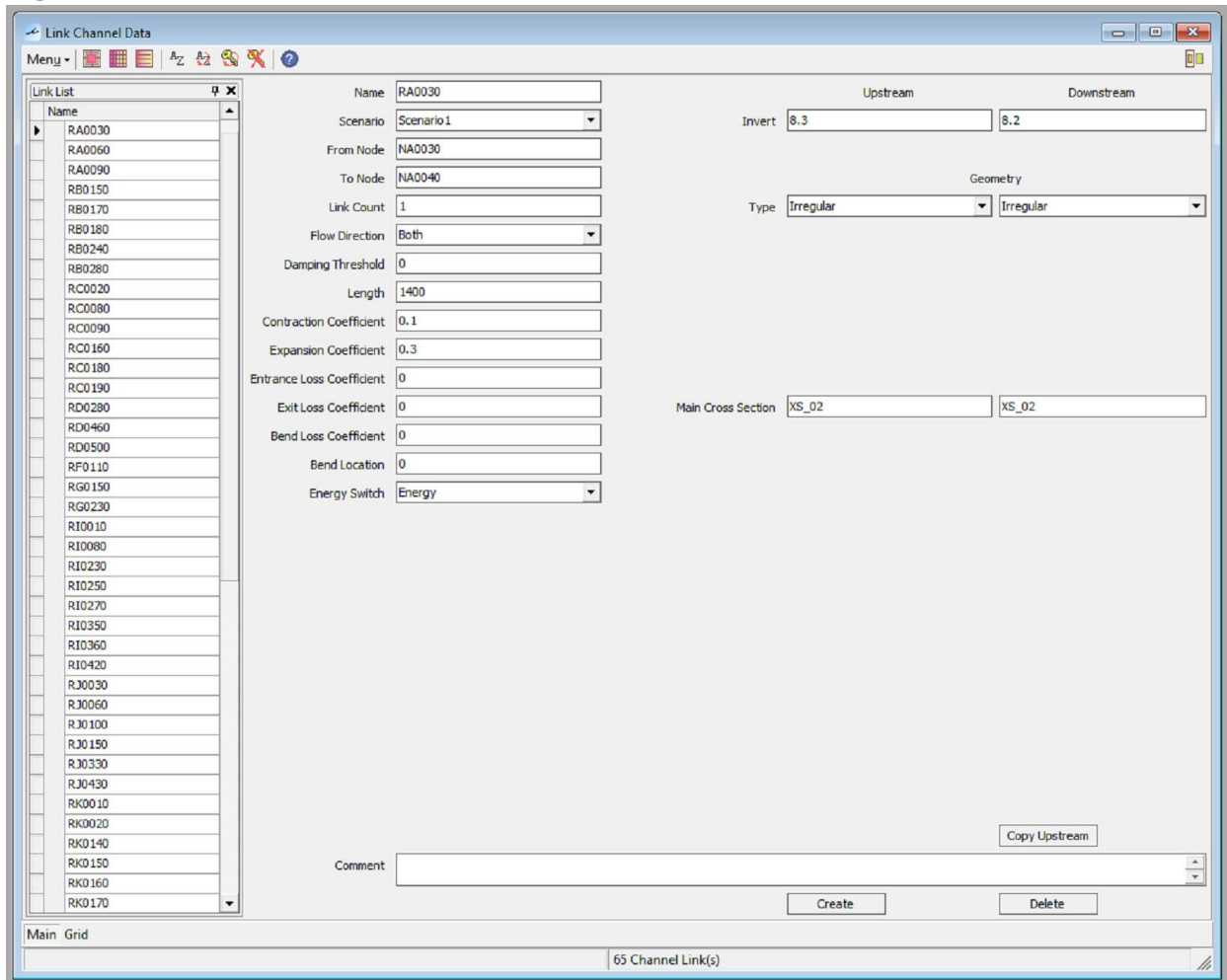

### 6.4.5 FLOODPLAIN STORAGE

Floodplain storage is included in ICPR4 by storage associated with the links and stage-area (or stage-volume) relationships associated with the nodes. Link storage is inherent to the feature dimensions and cross-sections when applied. Link and nodal storage should be explicitly captured within the model to ensure accurate predictions of peak stage.

Applicants are reminded that the Stormwater Division requires a proposed condition modeling approach that does not include surface ponding outside the proposed stormwater management system in the nodal storage to demonstrate that the level-of-service requirements are met on site. Per UDC Article 18, Appendix C14, attenuation calculations will be based only upon the volume available in designated stormwater ponds or wetlands. For example, runoff attenuation from street flooding must not be considered in proposed condition modeling, and stormwater management facilities must be sized to receive all on-site-generated runoff. All available surface ponding should be accounted for in the existing conditions model.

When proposed improvement include an encroachment in the existing 100-year floodplain on a site, compensating volume must be provided cup-for-cup and consider volume loss between

the seasonal high-water elevation and base flood elevation. The proposed compensating volume must be supported by volumetric calculations based on best available data.

Surface storage should be assigned to model nodes. Nodal storage should be developed using the following guidelines:

- To define nodal storage, stage-area relationships must be used since they are more readily checked and verified. The highest relationship stage must be greater than the 100-year peak stage. Stage-volume relationships are not allowed.
- The surface area of flow included in channel links, as included in the model, must be considered such that the channel cross-section (and therefore inherent storage volume) does not encroach on floodplain storage included in the node.
- Basin boundaries will serve as the control area for developing stage-area relationships. The maximum area in each stage-area relationship must not exceed the area within each basin.
- Stage/Area polygons must be developed representing nodal storage area as described in the ICPR4 support documentation. Applicants may develop stage-area relationship outside of ICPR4 but must still provide representative stage/area polygons.

Sub-surface storage areas greater than 0.001 acres should be assigned to model nodes only when explicitly included in the proposed stormwater management system for attenuation, such as an underground stormwater storage vault.

As described in Section 3.2, applicants are reminded that underground stormwater facilities are not acceptable unless justification and demonstration of reliable performance is provided to the Stormwater Division outside the ICPR4 model.



**Figure 6.4 ICPR4 Node Data GUI**

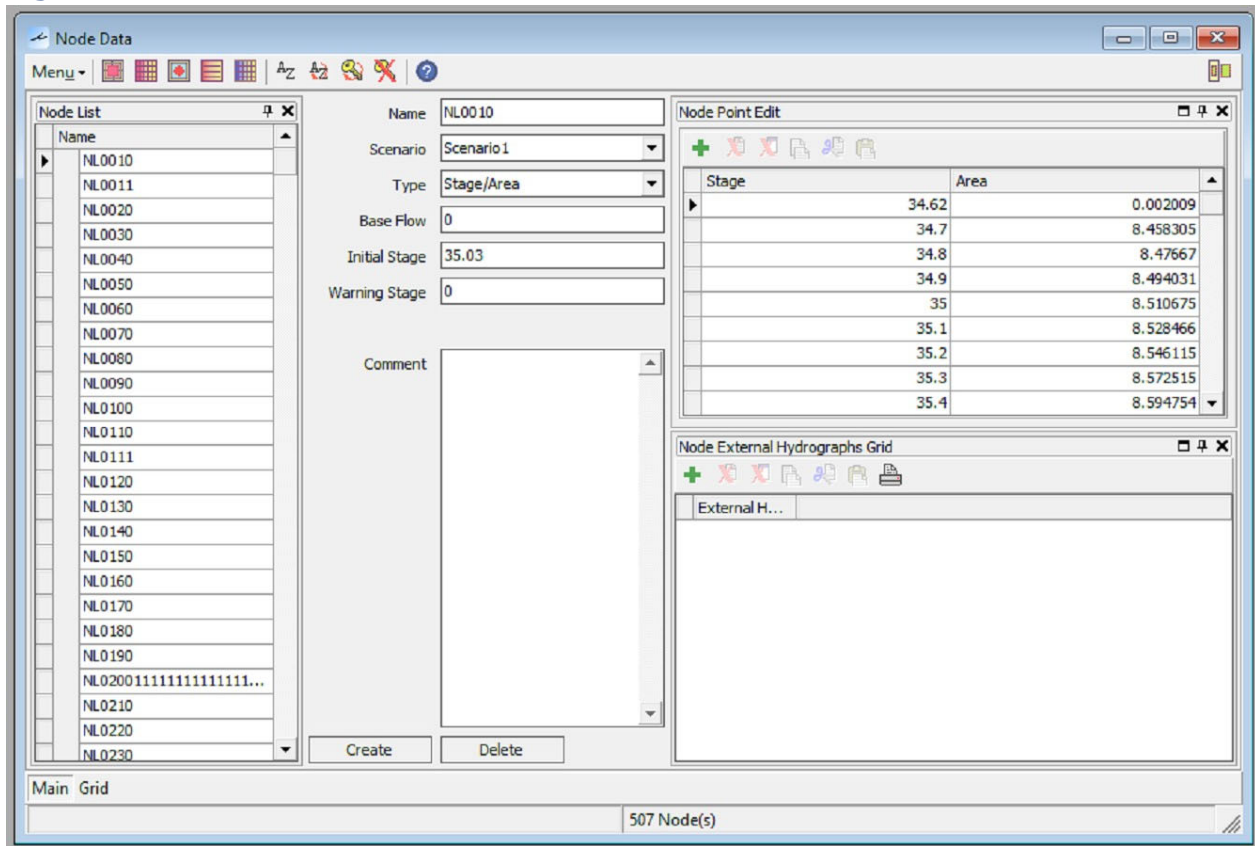

### 6.4.6 INITIAL CONDITIONS AND WARNING ELEVATIONS

Initial water surface elevations at nodes represent the starting hydraulic condition for the model and should be based on seasonal high-water elevations and normal pool elevations. The Stormwater Division recommends transforming the initial condition elevation to an area-coverage to review the appropriateness of initial water surface elevations relative to the ground surface.

Warning elevations should be assigned based on physical feature benchmarks such as crown of road, top of structure, etc. The Stormwater Division encourages assigning warning elevations, especially for proposed condition modeling, to help demonstrate that an adequate level of service is provided by the stormwater management system.

### 6.4.7 OVERLAND FLOW ROUTING

Overland flow connectivity must be included in the ICPR4 model such that all surface flows derived from the 100-year storm event are explicitly routed. For existing conditions, this likely includes non-channelized overland flow. Typically, additional non-channelized overland flow connectivity is not required for proposed conditions since the Stormwater Division requires a proposed condition modeling approach that does not include surface ponding outside the proposed stormwater management system.

Table 6.1 lists the general geometry guidelines for non-channelized overland flow connectivity. Geometries not listed may only be used for with prior approval from the Stormwater Division.

**Table 6.1 Suggested Overland Flow Geometry**

Geometry	Physical Equivalent
Irregular	Subbasin interconnection (overland flow); roadway.
Parabolic	Relatively flat roadway with slight horizontal curves.
Trapezoidal	Subbasin interconnection; roadway.

The Stormwater Division’s preferred non-channelized overland flow connectivity link type is an irregular weir. Generally, weir coefficients for overland flow should be within the range of 2.3 to 3.1. Lower weir coefficients within this range are appropriate for weirs with very wide crest breadths (long flow paths) and lower upstream head that would be expected to produce higher friction losses. Higher weir coefficients within this range are appropriate for weirs with narrow crest breadths (short flow paths) and higher upstream head that would be expected to produce lower friction losses. In all cases, hydraulic parameters should be developed for overland flow connectivity to represent physical conditions to the best extent practical and geometry should be based on surveyed or proposed grades. Weir coefficients outside of this general range may be used but must be justified with appropriate documentation and approved by the Stormwater Division.

**Figure 6.5 ICPR4 Link Weir Data GUI**

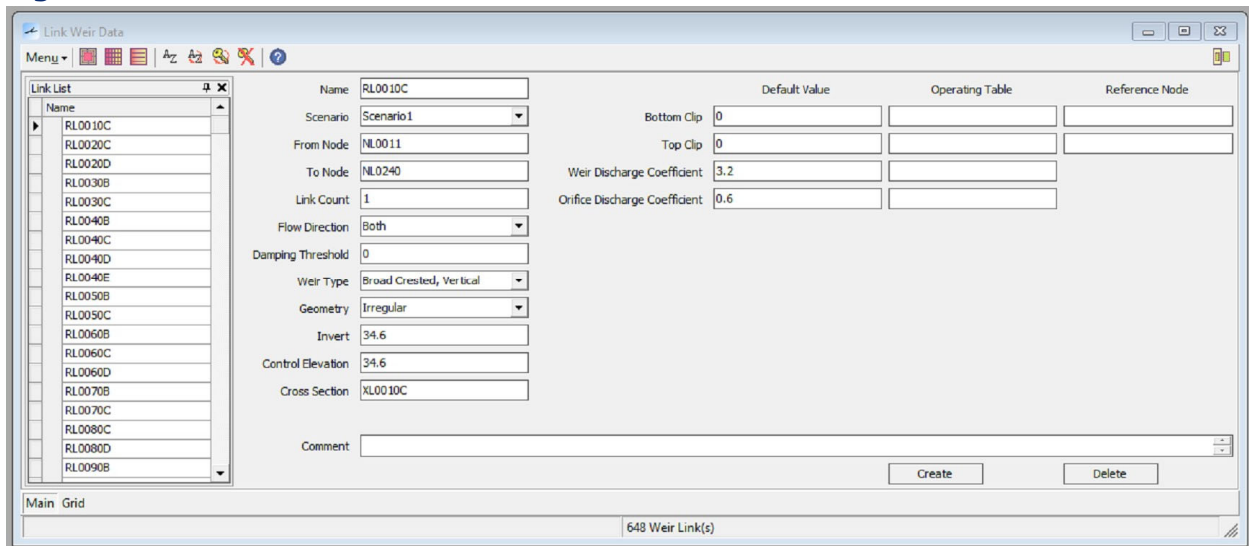

## 6.5 BOUNDARY CONDITIONS

Development of boundary conditions for the Hydrograph Method is necessary to ensure accurate on-site hydraulic calculations. Boundary conditions must be established based on the best available information, which commonly is an existing County Basin Model. Applicants are encouraged to request best available information for boundary conditions from the Stormwater Division and are advised that the Stormwater Division must approve boundary condition information that is not based on an existing County Basin Model. Model boundary conditions are typically in the form of a time-stage relationship and applied at boundary nodes

for the site-specific model. Including boundary conditions based on a County Basin Model does not require simulation of the Basin Model, such as required for the Model Incorporation Method (Section 7).

It may also be necessary for applicants to include non-contributing off-site areas or conveyances in the model to adequately incorporate boundary conditions.

## 6.6 SIMULATION MANAGER

For ICPR4, hydrologic and hydraulic routing control information is stored within the Simulation Manager. The Simulation Manager contains four tabs: General, Output Time Increments, Resources and Lookup Tables, and Tolerance and Options. The applicant must simulate the design storms to demonstrate compliance with County criteria. Additional design storms may be required by the Stormwater Division dependent on site conditions.

### 6.6.1 GENERAL

The General tab includes model run time controls. The start time should be set to time zero, and the end time should be set to ensure peak flows and stages are captured. For example, a simulation end time of 48 hours or more may be necessary for the 100-year 24-hour design storm.

The minimum and maximum calculation time steps should be assigned to be consistent with the time marching approach (Tolerance tab). Typically, the maximum calculation time should not exceed 60 seconds and depends on the routing time required for modeled conduits. The maximum allowed calculation time should not exceed the time required for a dynamic wave to pass through a modeled conduit during hydraulic routing. For site-specific models with a high level-of-detail, a maximum calculation time less than 30 seconds may be appropriate.

### 6.6.2 OUTPUT TIME INCREMENTS

Time increments should be established to capture the flow and stage hydrograph peaks for all model elements and allow for effective quality control. Typically, Hydrology time increments should be set to 5 minutes. Surface Hydraulics time increments should be set to 5 minutes near the storm peak, typically near hour 12 of the simulation for a 24-hour design storm, but may be set to 15 minutes for the remaining simulation period. The Stormwater Division may use smaller time increments during the review process, such as 1 minute, to check model stability, and applicants are encouraged to proactively complete similar quality control measures.

### 6.6.3 RESOURCES AND LOOKUP TABLES

Typically, no Resources or Lookup Tables are required based on the modeling approach described in this Manual. Applicants are referred to the ICPR4 support documentation for additional details.

### 6.6.4 TOLERANCES AND OPTIONS

Tolerances and Options within the Simulation Manager should be set to the following:

- Time Marching should be set to SAOR.
- Maximum Iterations should be set to 6.

- Over-Relaxation Weighting Factor should be set to 0.5.
- dZ Tolerance should be set to 0.001 foot.
- Maximum dZ should be 1 foot or less.
- Link Optimizer Tolerance should be set to 0.0001 foot.
- Initial Abstraction Recovery Time should be set to 24 but should not be relevant based on the modeling approach described in this Manual.
- Simple/Manual Basin Rainfall Opt. should be set to Global.
- Rainfall Name should be set based on current SWFWMD guidance for each simulated design storm, currently FLMOD.
- Rainfall Amount should be set based on current SWFWMD guidance for each simulated design storm.
- Storm Duration should be set to 24 hours unless a different duration design storm is being simulated.
- Default Damping Threshold (1D) should be set to 0.005 foot.
- Minimum Node Surface Area (1D) should be set to 43.5 square feet.
- Energy Switch should be set to Use Link Selection.

The applicant should check that the model does not generate errors or warnings of concern at the startup of the run. Unlike ICPR3, a pop-up does not signal when warnings and/or errors occur. Figure 6.6 shows the Simulation Manager tab where a text file with a list of warnings and errors is created at startup for ICPR4.

**Figure 6.6 ICPR4 Simulation Manager GUI**

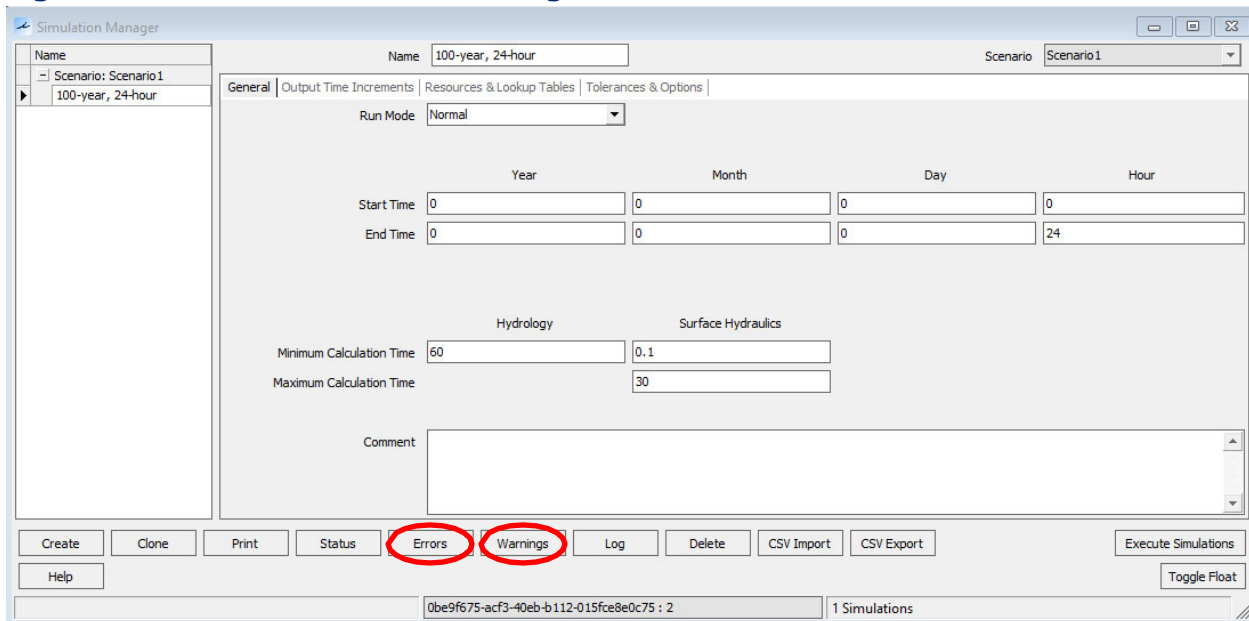

## 6.7 QUALITY CONTROL

A thorough quality assurance/quality control (QA/QC) process should be completed by the Engineer of Record for all stormwater models. **The Engineer of Record is fully responsible to complete QA/QC of all stormwater-related information included in the applicant submittals.**

To aid applicants, the Stormwater Division has provided quality control recommendations for ICPR4 in Section 8.1. These recommendations include using two automated tools developed by the Stormwater Division that operate against ICPR4 model input data: ICPR4 Input Data Comparator and ICPR4 Input Data QC Tool. The results of the Comparator and QC Tool must be included in the applicant submittals.

## 6.8 APPROACH-SPECIFIC SUBMITTAL REQUIREMENTS

In addition to the submittal requirements defined in Section 2.4, the following should be provided with submittals when the Hydrograph Method is used for hydrologic design: electronic copies of stormwater models, model-related spatial data, maps, and supporting calculations. More detail on these items is provided below. All submittal items should meet the standards established in Section 4.

### 6.8.1 STORMWATER MODELS

Submittals must include all stormwater models used for stormwater design. Applicants should include existing and proposed drawings or similar background images in ICPR4 to facilitate Stormwater Division review.

- An existing conditions model must be provided.
- A proposed conditions model must be provided.

### 6.8.2 MODEL-RELATED SPATIAL DATA

Submittals should include spatial information related to stormwater models, maps, or supporting calculations. At a minimum, the following spatial data should be provided with each submittal:

- Model Schematic including Basin (polygons), Node (points), and Link (polylines) elements for each modeled condition: Existing, Revised Existing, and Proposed.
- Model-predicted floodplains (polygons) for the 100-year 24-hour design storm for each modeled condition: Existing, Revised Existing, and Proposed.
- Hydrologic flow paths (polylines) for T<sub>c</sub> calculations within each basin and for each modeled condition. Each flow path should be segmented to show sheet, shallow concentrated, pipe, and channelized flow.
- Stage/Area (polygons) that represent the surface area of modeled nodal storage.
- Cross-Section (polylines) that represent the ground location of cross-section data used in the model.
- Topographic information for each modeled condition.

### 6.8.3 MAPS

Submittals should include maps necessary to demonstrate compliance with criteria included in this Manual. At a minimum, the following should be provided with each submittal:

- A map or maps showing the existing condition model schematic including model basins, nodes, pipes, channels, cross-sections, drop structures, and weirs.
- A map or maps showing the proposed condition model schematic including model basins, nodes, pipes, channels, cross-sections, drop structures, and weirs.

- A map or maps showing off-site contributing areas are consistent with site-specific survey.
- A map or maps showing hydrologic flow paths used to determine the Tc for each basin. The map should include basin boundaries with labels, model nodes, and the appropriate topography along with pertinent drainage features.
- A map or maps showing Stage/Area polygons used to develop nodal storage. The map should include basin boundaries with labels, model nodes, model channel links, and appropriate topography.
- A map or maps showing the existing conditions floodplains.
- A map or maps showing the proposed conditions floodplains.

#### 6.8.4 SUPPORTING CALCULATIONS AND SUMMARY TABLES

Submittals should include supporting calculations related to stormwater modeling and summary tables necessary to demonstrate compliance with criteria included in this Manual. At a minimum, the following should be provided with each submittal:

- Tc calculations as a spreadsheet.
- CN calculations as a spreadsheet.
- Stormwater treatment calculations to determine treatment volume and recovery time.
- Hydrologic and hydraulic calculations for stormwater management system features not explicitly included in the stormwater models.
- Summary tables to demonstrate compliance with County level-of-service criteria.
- Volumetric calculations to demonstrate cup-for-cup floodplain compensation, including cross-sections.
- Summary of model results for each modeled condition, including node peak stage and link peak flow.
- Results of the County's ICPR4 Input Data Comparator.
- Results of the County's ICPR4 Input Data QC Tool.

## 7 MODEL INCORPORATION METHOD

Per UDC Article 13, Section 124-252 (a)(1)a., the Model Incorporation Method is required for project sites greater than or equal to 35 acres of total area or greater than or equal to 8 acres of impervious area. The Model Incorporation Method requires using an existing County Basin Model to establish hydrologic and hydraulic conditions for stormwater design and analysis. The Stormwater Division will determine which Basin Model is appropriate for each project. For this method, the applicant will *incorporate* the land development project into the Basin Model and use the *incorporated* model to develop a revised existing condition (if warranted) and proposed condition for hydrologic design. Like the Rational Method and Hydrograph Method, compliance is then demonstrated by comparing results from each condition; however, the Model Incorporation Method is a demonstrative approach and does not use presumptive criteria.

Sarasota County has identified the importance of maintaining up-to-date watershed-scale stormwater models for planning purposes and development review. Stormwater models developed for this purpose are referred to as County Basin Models throughout this Manual. Streamline Technologies, Inc.'s Interconnected Channel and Pond Routing (ICPR) model is the software platform used to develop the County Basin Models. Although the watershed models were originally developed in previous versions of the software, the current generation of the ICPR model is ICPR4, which was first released in 2014. Applicants are advised that the County intends to migrate all existing ICPR3 watershed models to ICPR4 and applicants will be expected to use the ICPR4 models when using the Model Incorporation Method. Accordingly, technical guidance provided in this section has been developed specifically for ICPR4. When this Manual was prepared, the most recent release of ICPR4 was version 4.07.08, released on February 9, 2021.

ICPR3 was discontinued in 2016 and is no longer sold or supported by Streamline Technologies. More detailed discussion on the differences between ICPR3 and ICPR4 are provided in Section 8 of this Manual. Applicants interested in more information about ICPR3-related data needs and modeling approaches are referred to the previous version of this Manual published in 2007. Applicants interested in more information on ICPR4 than provided here are directed to the *ICPR4 Technical Reference* (Streamline Technologies, 2018) and additional materials linked within the ICPR4 help dialog. These ICPR4 materials are collectively referred to as *ICPR4 support documentation* throughout this Manual.

### 7.1 DESIGN APPROACH DESCRIPTION

Within ICPR4, hydrologic and hydraulic input data and simulation controls are stored as unique scenarios (Section 8.2). Therefore, applicants can complete hydrologic and hydraulic calculations for existing conditions, revised existing conditions, and proposed conditions within a single ICPR4 model using three scenarios or create three ICPR4 models each with one scenario. The computational results are the same; however, **the Stormwater Division strongly prefers applicants provide one ICPR4 model with three scenarios**. For simplicity, this Manual considers unique hydrologic and hydraulic calculations for different drainage conditions to be a *model* which is synonymous with an ICPR4 scenario.

The applicant will use a County Basin Model to establish existing conditions and then use the existing condition model data as base data to develop a proposed condition model. The

applicant can revise the existing condition data as provided in Section 3.3. For proposed conditions, applicants will design a stormwater management system and revise on-site model elements as necessary to incorporate the design elements including site grading, site paving, hydraulic structures, and stormwater management facilities. In general, the revised model data should be developed as discussed in this Manual, ICPR4 support documentation provided by Streamline Technologies, and standard modeling practices. At a minimum, the developed stormwater models must meet the following criteria:

- The latest ICPR4 version should be used to develop stormwater models.
- An existing condition model must be developed based on a County Basin Model or a revised existing condition as provided in Section 3.3.
- A proposed condition model must be developed by revision of the existing condition model or a revised existing condition model.
- All major stormwater design elements must be included in the proposed conditions model.
- Model differences between the existing and revised existing conditions must be clearly identified and supported by accompanying documentation.
- Model differences between the existing or revised existing and proposed conditions must be clearly identified and supported by accompanying documentation.
- Model elements and parameters must be developed following standard engineering practices and this Manual.
- Model simulations must be stable and produce reasonable, repeatable results.

Stormwater management systems typically consist of stormwater inlets, pipes, and ponds. Typically, stormwater ponds are designed prior to stormwater inlets and stormwater inlets are designed prior to stormwater pipes. However, stormwater management system design, hydrologic, and hydraulic calculations often require an iterative approach to ensure design criteria are met. Development of a stormwater model allows for hydrologic and hydraulic calculations for all elements of the proposed stormwater management system to occur simultaneously.

Proposed stormwater management systems will be designed for long life, low cost, and ease of maintenance. The system must be demonstrated to meet design criteria provided in this Manual (Section 3) and the UDC.

#### 7.1.1 EXISTING CONDITIONS MODEL

The Stormwater Division generally maintains Basin Models and related GIS data on an ftp site (<ftp.scgov.net/stormwater/ICPRv4/>) where model data are organized by Bayshed. Each Bayshed directory contains associated County Basin Models and geographical information system (GIS) data. Figure 7.1 is a map showing the County Basin Models by modeled watershed area as existed at the time of this Manual.

Occasions may arise where the most applicable Basin Model is not available on the County's ftp site. The Stormwater Division will determine which Basin Model is appropriate for use as the existing conditions model. Applicants may use the Basin Model data *as is* for their project site or develop revised existing conditions following Stormwater Division guidelines (Section 3.6). Applicants should follow the hydrologic and hydraulic calculation procedures described in Section 7.1.3 to develop the revised existing condition model.



**Figure 7.1 Watersheds for County Basin Models**

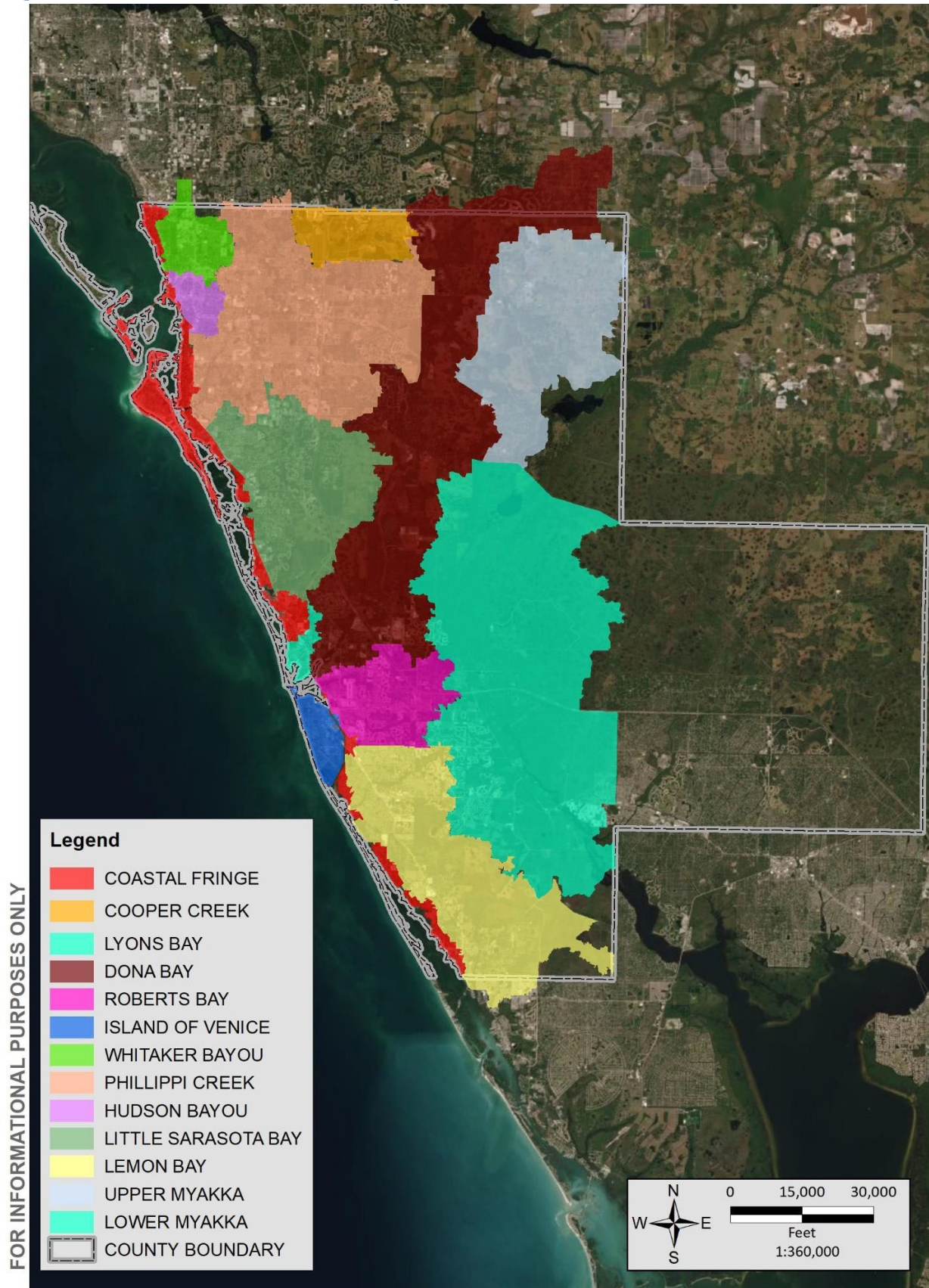

### 7.1.2 PROPOSED CONDITIONS MODEL

Similar to the Hydrograph Method described in Section 6, applicants will develop a proposed conditions model by revision of the (revised) existing conditions model. Applicants will make model revisions based on the proposed stormwater design and land development. The proposed condition model elements and parameters must be developed to match the proposed stormwater design, including submitted drawings, maps, and supporting calculations. Applicants should follow the hydrologic and hydraulic calculation procedures described in Section 7.1.3 to develop the proposed condition model.

### 7.1.3 HYDROLOGIC AND HYDRAULIC CALCULATIONS

For hydrologic calculations, the applicant will develop the 10-year, 25-year, and 100-year design storm using the appropriate 24-hour rainfall depth and distribution provided in the existing County Basin Model. Applicants are advised that new rainfall depth and distribution guidance may be developed in association statewide stormwater rules currently under consideration by the Florida Department of Environmental Protection (FDEP). Applicants are encouraged to review the most recent Southwest Florida Water Management District (SWFWMD) guidance and discuss perceived conflicts with the Stormwater Division.

The design storm hydrograph will be applied to unique contributing areas, which are represented in the model by basins. Applicants will also assign runoff parameters and a unit hydrograph to each basin, which will in turn be used to determine the runoff-response from each basin. Runoff-response hydrographs will then be routed through hydraulic features. Hydrologic simulation controls dictate the numeric calculations. While hydrologic calculations will be performed by the model, applicants must develop supporting data for the model inputs as needed. Applicants should generally follow the procedures below to develop model input data for hydrologic calculations of each modeled drainage condition (Section 7.3).

- Delineate off-site contributing areas (if any).
- Delineate the contributing area (basin) for each stormwater management system element included in the stormwater model.
- Determine the total area and impervious area for each basin.
- Determine the time of concentration for each basin.
- Determine the curve number for each basin.
- Determine the peaking factor and unit hydrograph for each basin.
- Determine the loading node for each basin.

For hydraulic calculations, applicants will identify significant hydraulic features for routing. These features will be included in the hydraulic network. Nodes represent locations for model-stage prediction, such as stormwater ponds, inlet locations, storm pipe junctions, etc. Links represent conveyance features such as pipes, channels, and weirs. Applicants will develop the hydraulic network and parameters based on known or proposed information. For example, the revised existing condition parameters should be based on a site survey. The proposed condition hydraulic network and parameters must be developed to match the proposed stormwater design, including submitted plan drawings and supporting calculations. Hydraulic simulation controls dictate the numeric calculations. While hydraulic calculations will be performed by the stormwater model, applicants must develop supporting data for the model inputs as needed. Applicants should generally follow the procedures below to develop model input data for hydraulic calculations of each modeled drainage condition (Section 7.4).

- Develop the hydraulic network.
- Determine the stage-area relationship for each node.
- Determine the initial condition for each node based on hydraulic conveyance connections and tailwater conditions.
- Determine the invert elevation, geometry, dimensions, and roughness (material) of each conveyance.
- Determine hydraulic losses associated with each conveyance.
- Determine necessary overland flow connection locations.

#### 7.1.4 DEMONSTRATED COMPLIANCE

Model results will be used to demonstrate compliance with County and SWFWMD criteria as established in Section 3 of this Manual. In short, the criteria are:

- The existing condition model or revised existing condition model results will establish off-site time-stage relationships, which demonstrate potential off-site impacts.
- The proposed condition model results must clearly demonstrate proposed peak stage adjacent to habitable structures. No flooding of habitable structures is allowed.
- The proposed condition model results must clearly account for all proposed off-site discharge locations. No off-site discharge is allowed except through the proposed stormwater management system.
- The proposed condition model results must clearly demonstrate the stormwater management systems ability to convey and attenuate the 10-year, 25-year, and 100-year design storms. Ponds must attenuate the 100-year design storm with allowance for 0.5 foot of freeboard.
- The proposed condition model results must clearly demonstrate no adverse off-site impacts. Adverse off-site impacts are defined as node peak-stage increases greater than 0.01 foot unless prior approval is provided by the Stormwater Division.
- The proposed condition results must clearly demonstrate proposed treatment volume meets Sarasota County and SWFWMD treatment volume requirements.
- The proposed condition results must clearly demonstrate proposed discharge of treatment volume meets SWFWMD pond recovery requirements.

The Stormwater Division requires a proposed condition modeling approach that does not include surface storage outside the proposed stormwater management system to easily demonstrate that the level-of-service requirements are met. Applicants should summarize the model results in a table or tables to demonstrate compliance with level-of-service criteria. Inlet level-of-service compliance is typically demonstrated separately from ICPR4 results. Applicants must demonstrate that stormwater inlets and pipes meet the County's level-of-service criteria (Section 3.3).

The Stormwater Division has developed automated tools to aid applicants in demonstrating compliance. The County's ICPR4 Input Data Comparator returns a summary of model changes between two ICPR4 models. The Comparator should be used to document changes made from existing conditions to revised existing conditions or proposed conditions. The County's ICPR4 Input Data QC Tool performs quality control checks on model input data based on standard modeling practice. The Tool should be used as part of the applicant's quality control process but should not be used in lieu of other quality control practices typical to stormwater model development.

Applicants are reminded that all submittals requiring Stormwater Division review must include the items below to demonstrate compliance as described in Section 2.4 of this Manual.

- Stormwater Management Plan. Proposed easements must be shown in construction plan drawings and meet County criteria (UDC Article 18, Appendix C13a, C13b, C13c, and C29).
- Subdivision Plat and Site Development Plan Stormwater Review Checklist (UDC Article 18, Appendix C24).
- Construction Plan Stormwater Review Checklist (UDC Article 18, Appendix C25).
- Construction Plan Stormwater Design Summary (UDC Article 18, Appendix C26a) signed-and-sealed by the Engineer of Record.
- Construction Plan Stormwater Design Summary for Net Improvement (UDC Article 18, Appendix C26b) signed-and-sealed by the Engineer of Record, if warranted.

The Stormwater Division may require demonstration of compliance with additional criteria as site conditions warrant. The Stormwater Division **strongly recommends applicants request a stormwater methodology meeting** to establish the County Basin Model appropriate for use, stormwater criteria required, and how compliance is best demonstrated within a submittal. Applicants are advised that County Basin Models are continually being updated and the most recent Basin Model will be considered best available data at the time of submittal.

## 7.2 MODEL DEVELOPMENT

In ICPR4, model elements typically include basins, nodes, links, and cross-sections. Runoff-response hydrographs are calculated by the model based on basins and hydrologic parameters (Section 7.3). Stormwater routing is calculated by the model based on the hydraulic network and hydraulic parameters (Section 7.4). For the Model Incorporation Method, boundary conditions are already defined by the County Basin Model (Section 7.5).

For the Model Incorporation Method, the existing conditions model is available and model schematic is also available as GIS data. The Stormwater Division encourages applicants to carefully review the existing conditions model and model schematic to determine whether development of a revised existing condition is warranted and to plan for stormwater management system design.

Applicants are reminded that for well-developed revised existing condition or proposed condition models, basins must be delineated at a scale to appropriately define the runoff-response and load representative node locations within the hydraulic network. The hydraulic network must be defined with sufficient detail to represent physical conditions on-site. At a minimum, the applicant will need to incorporate hydraulic elements of the primary stormwater management system into the model(s). Applicants may explicitly model pipes for secondary conveyance systems where normal flow is likely to occur or separately perform hydraulic calculations for the secondary conveyance system (Section 8.3).

For this Manual, the primary stormwater management system is defined as hydraulic features that are the controlling features during all design storms. Primary features typically convey stormwater through the project site or discharge the stormwater from the project site, such as main storm drains for a roadway or pond control structures. The secondary stormwater management system is defined as all other hydraulic features that

collect and convey stormwater to the primary system, such as roadway inlets and lateral storm drains, parking lot stormwater inlets and drains, swales, etc.

Proposed condition model development is often an iterative process during stormwater design. Proposed stormwater elements should be included in the stormwater model and modified as needed during the design process to meet compliance criteria. Model schematics used for stormwater design must be provided with applicant submittals as maps and spatial data. For ICPR4, model schematic should be represented spatially within ICPR4 and proposed condition drawings should be included as background images to support the model schematic.

### 7.3 HYDROLOGIC PARAMETERS

Hydrologic parameters are assigned to model basins and are an important part of the stormwater design process. The Natural Resources Conservation Service (NRCS) *Technical Release 55 (TR-55)* and the *Sarasota County Watersheds Floodplain Model Methodology Report* (Attachment 10) establish the methods that must be used to develop model basin parameters. **The Stormwater Division recommends applicants use the Simple Basin Data approach for hydrologic data input in ICPR4** (Figure 7.2). Applicants need only develop hydrologic parameters for revised existing condition or proposed condition models. ICPR4’s Manual Basin Data approach allows users to calculate basin parameters based on data layers and related tables within ICPR4. Applicants are referred to the ICPR4 support documentation for additional details on this approach.

**Figure 7.2 ICPR4 Simple Basin Data GUI**

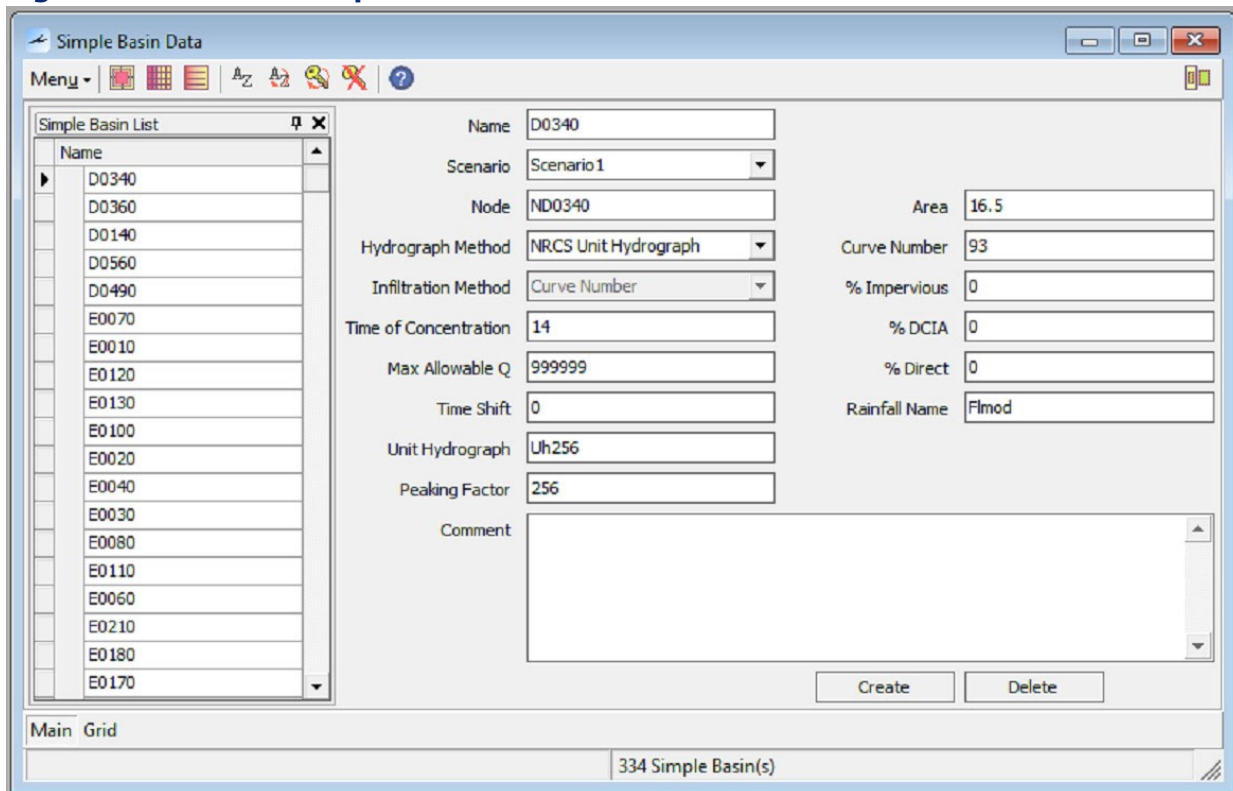

### 7.3.1 BASIN AREA

Basin area in acres should be determined using the model schematic and calculated in geographical information system (GIS) or computer-aided design (CAD) for revised existing and proposed conditions. **The sum of all basin areas must be equal for the existing, revised existing, and proposed conditions.**

While rare, it is possible that a land development project site will overlap two or more County Basin Models. In such case, applicants must provide documentation to ensure that the total modeled area is unchanged between existing, revised existing, and proposed conditions.

### 7.3.2 IMPERVIOUS AREA

Impervious area can be divided into two categories, directly connected impervious area (DCIA) and unconnected impervious area. DCIA is impervious area that is directly connected to the basin discharge point via continuous impervious surface(s) such that DCIA-generated runoff does not flow over pervious surfaces. In contrast, unconnected impervious area is not continuously connected, and therefore generated runoff may flow over pervious surfaces and subsequently infiltrate. DCIA should be directly calculated from a site survey or the proposed design plan drawings and must be explicitly assigned to each basin as a percent. Applicants must provide sufficient documentation of DCIA to validate the model input data.

The Stormwater Division requires applicants submit a spreadsheet or tabulation within a drawing that details planned impervious area. Impervious quantities must be documented by impervious type: roofs and driveways, streets, sidewalks, ponds, wetlands, etc. For Master Stormwater Management Plans, impervious area must be defined by specific areas such as per model basin and provided in the form of a tracking log (or similar) for use during the life of the Master Stormwater Management Plan.

### 7.3.3 CURVE NUMBER

Since DCIA is explicitly assigned as a basin parameter, the basin curve number (CN) must therefore only represent pervious and unconnected impervious areas. The Stormwater Division has developed and tested a simplified CN approach for pervious areas in Sarasota County, which requires CN equal to 78 be used for all pervious areas and CN equal to 98 be used for all unconnected impervious areas. The basin CN is then calculated as the area-weighted average of the pervious and unconnected impervious area. Attachment 10 provides the *Sarasota County Watersheds Floodplain Model Methodology Report* and further discussion of this approach.

### 7.3.4 TIME OF CONCENTRATION

The estimated time of concentration ( $T_c$ ) must be developed using a segment velocity approach that explicitly considers shallow overland flow, concentrated overland flow, channelized flow, and pipe flow segment times as warranted. Section 5.3 provides additional discussion of  $T_c$ . The TR-55 methodology shall be used with a minimum  $T_c$  of 10 minutes. The Stormwater Division will make final determinations on whether estimated time of concentration is reasonable.

Attachment 6 includes a template for providing  $T_c$  calculations. Hydrologic flow paths used to represent the hydrologically most distant flow path for  $T_c$  calculations must be included in

applicant submittals, typically as a map. The Stormwater Division will review all calculated travel times and accompanying hydrologic flow paths for reasonableness.

### 7.3.5 UNIT HYDROGRAPHS AND PEAK RATE FACTORS

The NRCS Unit Hydrograph approach must be used. A peaking factor of 100 must be used for basins in an undeveloped condition and a peaking factor of 256 must be used for basins in a developed condition. A mix of developed and undeveloped conditions may exist within the project area. Within ICPR4, the Uh256 unit hydrograph should be used with peaking factor 256, and the Uh100C unit hydrograph should be used with peaking factor 100. Attachment 11 provides additional unit hydrograph information.

Applicants need to receive approval from the Stormwater Division to use peak rate factors and/or unit hydrographs not described above. Unless impacted by development, peak rate factors and unit hydrographs should be consistent with the County Basin Model.

## 7.4 HYDRAULIC PARAMETERS

Hydraulic parameters are assigned to features in the hydraulic network and are an important part of the stormwater design process. Applicants need only develop hydraulic parameters for revised existing condition or proposed condition models.

The Stormwater Division requires applicants use ICPR4 pipe links (Figure 7.3) to represent pipe flow in storm drains, channel links (Figure 7.4) to represent channel flow in natural or man-made channels and ditches, weir links (Figure 7.6) to represent overland flow or weir flow, and drop structure links to represent features that combine weir and pipe flow such as control structures. Applicants must also establish initial water elevations and stormwater management system surface storage using nodes (Figure 7.5) in ICPR4.

### 7.4.1 DIMENSION AND ELEVATION DATA

Dimension and elevation data for features included the model hydraulic network should be based on site survey for revised existing conditions and stormwater management system design for proposed conditions. Feature parameters such as feature length, invert elevation(s), geometry, and dimensions must match these data sources. As provided in Section 4, dimension and elevation information should be generated using the following horizontal and vertical coordinate system information:

- State Plane Coordinate System.
- Florida West Zone (Zone 3626 – FIPS 0902).
- North American Datum of 1983 (NAD83) (2011 Adjustment).
- North American Vertical Datum of 1988 (NAVD88) vertical units in US Survey Feet.

Applicants are advised that required coordinate system is based on the best available information and County standards at the time this Manual was developed. County standards may evolve as future vertical and horizontal datums are developed. Additionally, some County Basin Models in ICPR3 were developed using the National Geodetic Vertical Datum of 1929 (NGVD29). If elevation information is developed based on a multiple vertical datums, the elevation conversion process should be documented and provided as part of the submittal. When using Basin Models developed based on NGVD29, the Stormwater Division accepts datum conversion such that NAVD88 + 1.08 feet = NGVD29.

For hydraulic features that require model cross-sections, cross-section locations should be selected to best represent the physical conveyance and be based on survey or design data. For channel links, cross-sections locations should avoid transitional areas such as immediately adjacent to piped conveyance or bends in the channel. For channels of uniform dimensions, such as man-made ditches, one cross-section may be appropriate to represent the upstream and downstream channel section.

Applicants are reminded that feature names must be consistent between model-related spatial data, stormwater models, supporting calculations, maps, and drawings.

**Figure 7.3 ICPR4 Link Pipe Data GUI**

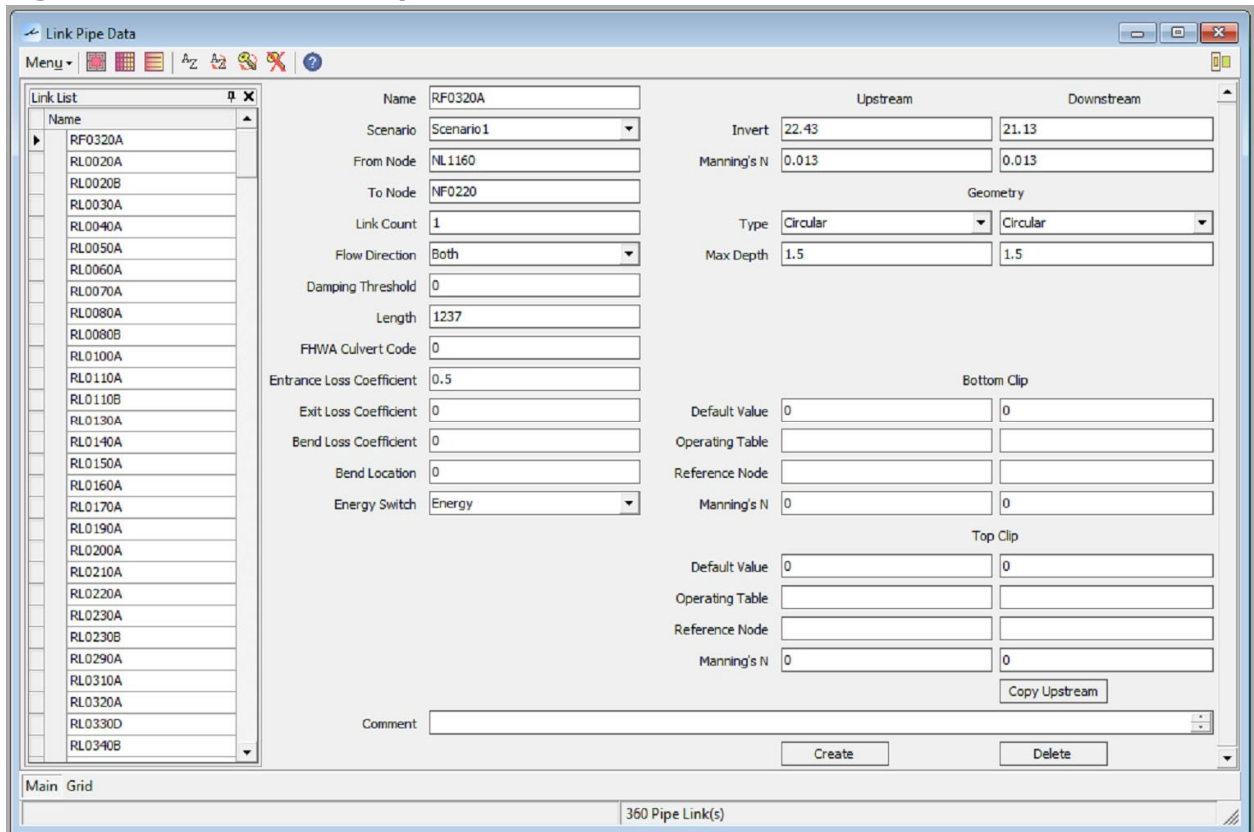

### 7.4.2 SOLUTION APPROACHES

Solution approaches for model links should consider available model information, relevant assumptions, and modeling goals. The Stormwater Division recommends the solutions approaches below, which are applicable for the most common modeling scenarios within the County. Applicants are referred to the ICPR4 support documentation for additional details on these approaches.

- Pipes and Channels: The Energy Switch should be set to Energy.
- Weirs: The Weir Type should be set to Broad Crested, Vertical, Sharp Crested, Vertical, or Horizontal as appropriate. The Weir Type should not be set to Paved Road, Vertical or Gravel Road, Vertical.
- Drop Structures: The Energy Switch and Weir Type should follow the guidance for Pipes and Weirs. The Solution should be set to Combined and Increments set to 0, which establishes an interval halving approach. The Solution may be set to Split if velocity



predictions are required, but users should review these links for solution stability. A fixed interval approach, such as setting Solution to Combined and Increments to 10, should not be used.

### 7.4.3 MANNING’S COEFFICIENT

Manning’s n is a coefficient that represents hydraulic resistance in Manning’s equation and is used by ICPR4 for pipe, drop structure, and channel links. For links assigned an irregular cross-section, Manning’s n can be assigned to individual station-elevation pairs. Applicants are advised that while it is possible to assign Manning’s n values to station-elevation pairs used for weir cross-sections, Manning’s n is not considered by ICPR4 when calculating weir flow.

Manning’s n is typically assigned to closed conduits based on material and to open channels by comparison to photos of studied systems. Literature values for Manning’s n are summarized in the ICPR4 support documentation and applicants are also directed to the Federal Highway Administration (FHWA) *Hydraulic Design of Highway Culverts* for additional information. Applicants must be consistent in application of Manning’s n values. For example, all concrete pipe should be assigned the same Manning’s n value.

**Figure 7.4 ICPR4 Link Channel Data GUI**

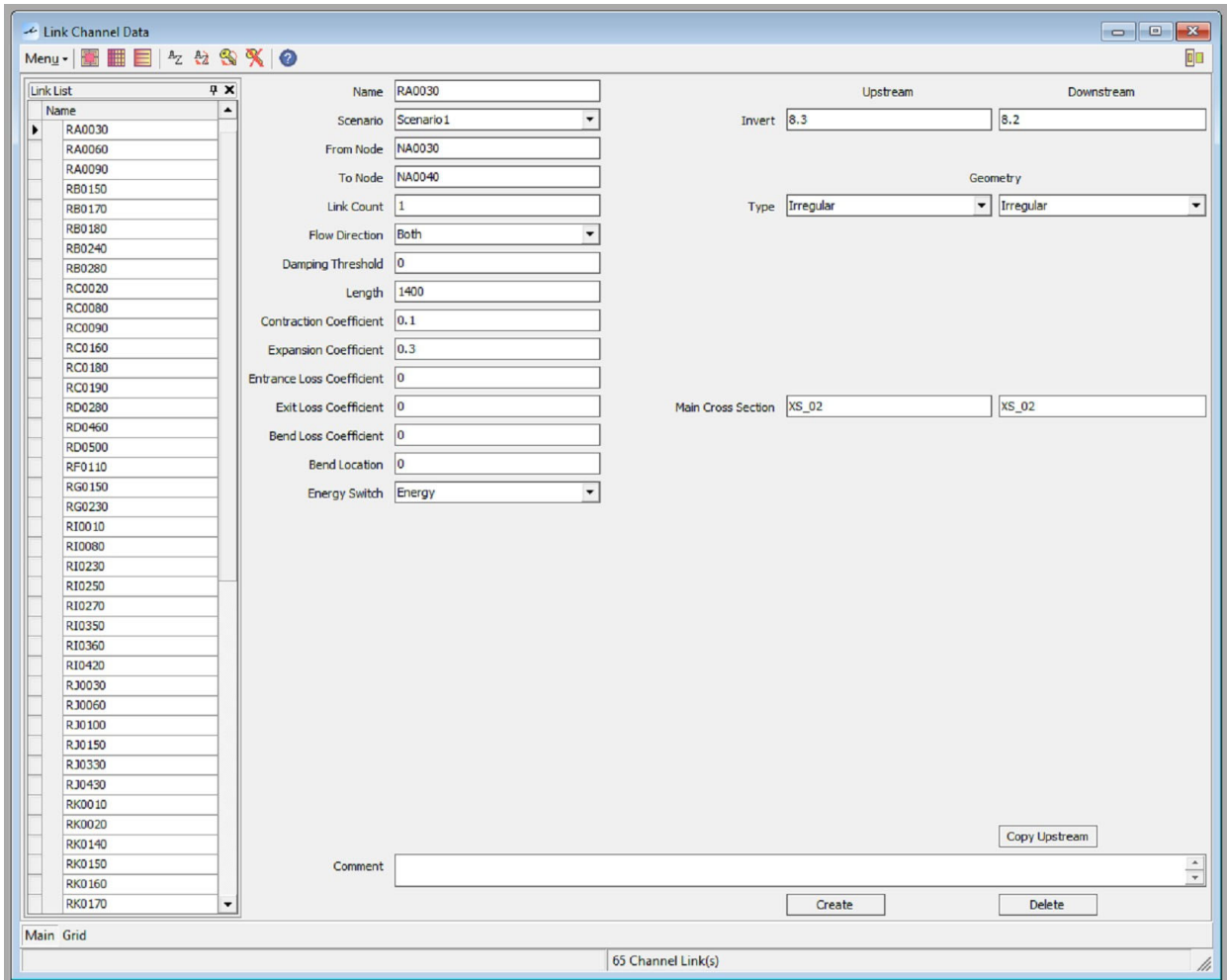

#### 7.4.4 LOSS COEFFICIENTS

In general, loss coefficients should be assigned based on the ICPR4 support documentation. Entrance losses should represent the efficiency (or energy loss) of the model element's inlet to smoothly transition flow from upstream. Exit losses should represent the energy loss when flow transitions from the model element downstream. Entrance and exit losses are typically assigned to pipe links and the pipe element of drop structure links. In some cases, entrance and exit losses should also be assigned to channel links. Given the expected level of detail required for proposed condition modeling, bend losses should typically not be necessary. Applicants must adhere to the general guidance provided below:

- All pipe links must be assigned an entrance loss greater than zero based on the most representative FHWA inlet description as described in *Hydraulic Design of Highway Culverts, Third Edition, Table C-2* (FHWA, 2012).
- All hydraulic links discharging to a pond, lake, wetland, or other large storage area must be assigned an exit loss of 1.0.

Applicants should exercise good engineering judgment when assigning entrance, exit, or bend losses outside of the situations described above. The Stormwater Division will make the final determination on disputed loss coefficients.

#### 7.4.5 FLOODPLAIN STORAGE

Floodplain storage is included in ICPR4 by storage associated with the links and stage-area (or stage-volume) relationships associated with the nodes. Link storage is inherent to the feature dimensions and cross-sections when applied. Nodal storage will represent all storage that is not represented by the links and is necessary in the hydraulic routing to accurately predict peak stage. Link and nodal storage should be explicitly captured within the model to ensure accurate predictions of peak stage.

Applicants are reminded that the Stormwater Division requires a proposed condition modeling approach that does not include surface ponding outside the proposed stormwater management system in the nodal storage to demonstrate that the level-of-service requirements are met on site. For example, runoff attenuation from street flooding must not be considered in proposed condition modeling, and stormwater management facilities must be sized to receive all on-site-generated runoff.

Surface storage should be assigned to model nodes. Nodal storage should be developed using the following guidelines:

- To define nodal storage, stage-area relationships must be used since they are more readily checked and verified. The highest relationship stage must be greater than the 100-year peak stage. Stage-volume relationships are not allowed.
- The surface area of flow included in channel links, as included in the model, must be considered such that the channel cross-section (and therefore inherent storage volume) does not encroach on floodplain storage included in the node.
- Basin boundaries will serve as the control area for developing stage-area relationships. The maximum area in each stage-area relationship must not exceed the area within each basin.

- Stage/Area polygons must be developed representing nodal storage area as described in the ICPR4 support documentation. Applicants may develop stage-area relationship outside of ICPR4 but must still provide representative stage/area polygons.

Sub-surface storage areas greater than 0.001 acres should be assigned to model nodes only when explicitly included in the proposed stormwater management system for attenuation, such as an underground stormwater storage vault.

As described in Section 3.2, applicants are reminded that underground stormwater facilities are not acceptable unless justification and demonstration of reliable performance is provided to the Stormwater Division outside the ICPR4 model.

**Figure 7.5 ICPR4 Node Data GUI**

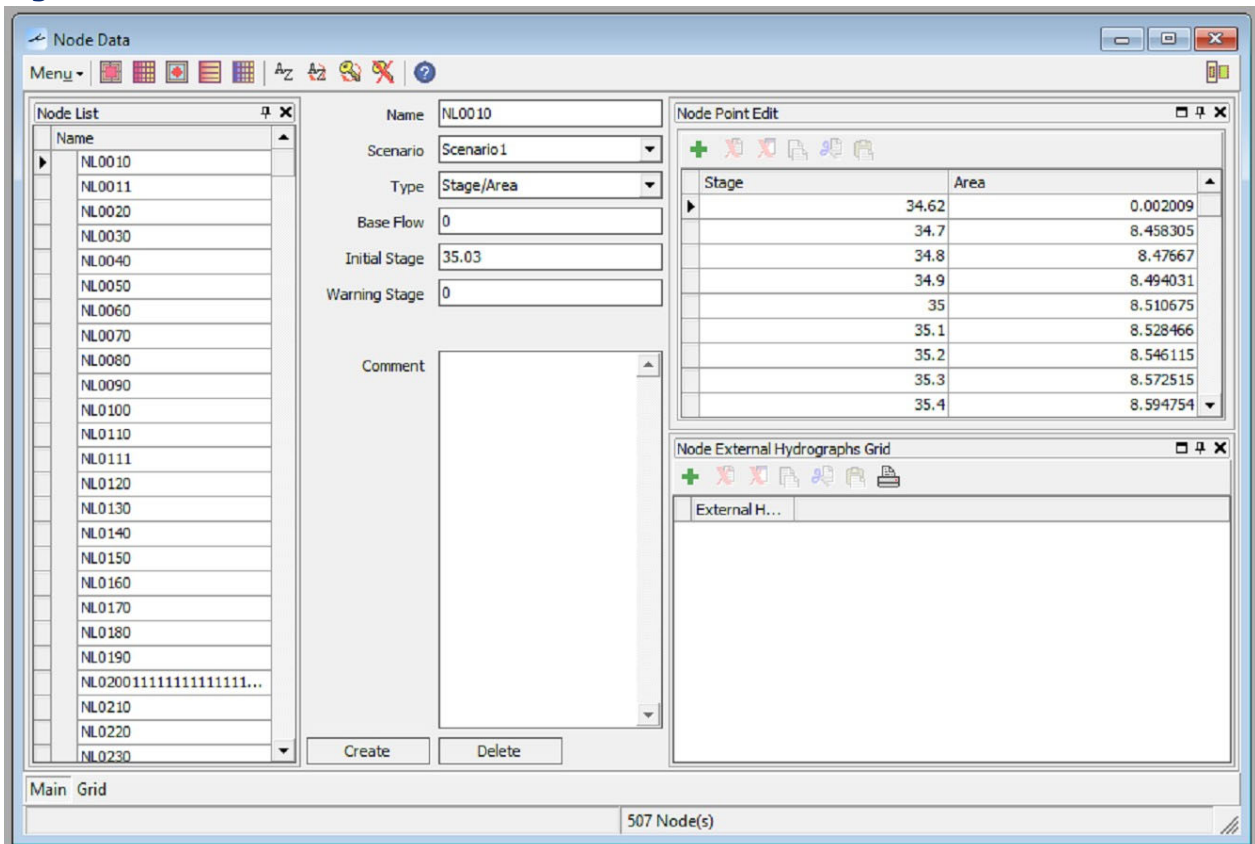

#### 7.4.6 INITIAL CONDITIONS AND WARNING ELEVATIONS

Initial water surface elevations at nodes represent the starting hydraulic condition for the model and should be based on seasonal high-water elevations and normal pool elevations. The Stormwater Division recommends transforming the initial condition elevation to an area-coverage to review the appropriateness of initial water surface elevations relative to the ground surface.

Warning elevations should be assigned based on physical feature benchmarks such as crown of road, top of structure, etc. The Stormwater Division encourages assigning warning elevations, especially for proposed conditions modeling, to help demonstrate that an adequate level of service is provided by the stormwater management system.

### 7.4.7 OVERLAND FLOW ROUTING

Overland flow connectivity must be included in the ICPR4 model such that all surface flows derived from the 100-year storm event are explicitly routed. For revised existing conditions, this likely includes non-channelized overland flow. Typically, additional non-channelized overland flow connectivity is not required for proposed conditions since the Stormwater Division requires a proposed condition modeling approach that does not include surface ponding outside the proposed stormwater management system.

**Figure 7.6 ICPR4 Link Weir Data GUI**

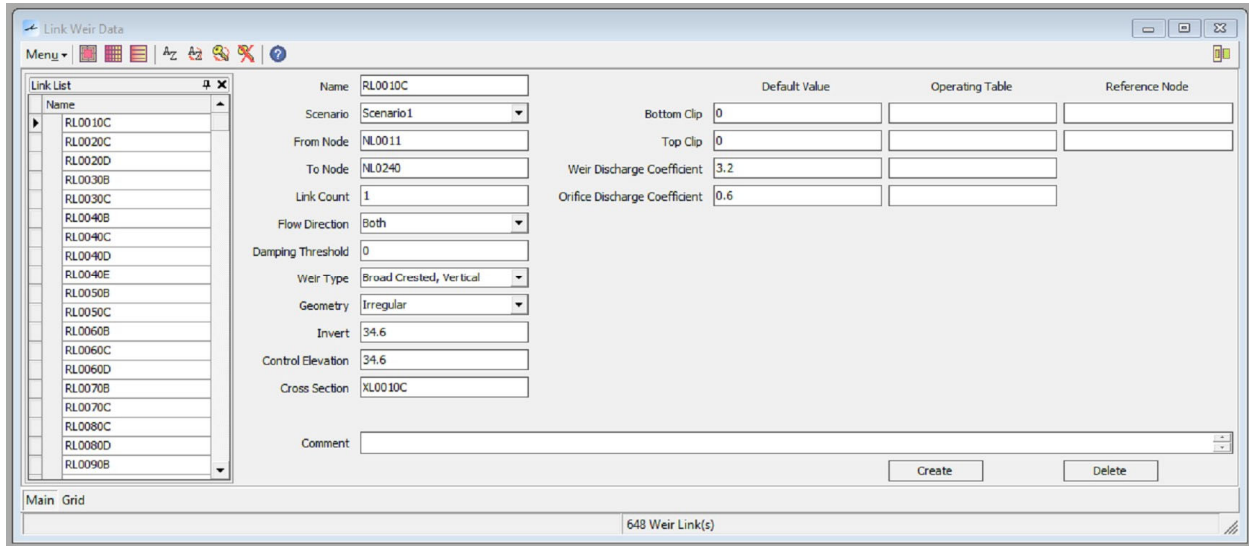

Additional detail for non-channelized overland flow routing that may be required for revised existing condition models is provided in Section 6.4. Applicants are advised that changes to overland flow weir coefficients between existing and revised existing conditions will be scrutinized by the Stormwater Division. In all cases, hydraulic parameters should be developed for overland flow connectivity to represent physical conditions to the best extent practical, geometry should be based on surveyed or proposed grades, and final approval of overland weir parameters will be made by the Stormwater Division.

## 7.5 BOUNDARY CONDITIONS

For the Model Incorporation Method, boundary conditions for the land development site are inherently established by the Basin Model. Applicants are not allowed to make off-site revisions to the County Basin Model for any model condition without direct approval from the Stormwater Division, except for when necessary to revise immediately adjacent off-site areas or conveyances to provide adequate connectivity between the project area and remaining County Basin Model.

## 7.6 SIMULATION MANAGER

In general, no modifications are required to the Simulation Manager when using a County Basin Model if only the 100-year 24-hour design storm is required. However, the applicant should check that model simulations do not generate errors or warnings of concern at startup. Modifications to simulation controls for the 100-year 24-hour design storm require Stormwater Division approval.

The applicant may need to simulate other events requested by County staff, which will likely require modifications to the Simulation Manager. Additional discussion on the Simulation Manager is provided below for this purpose. Similar guidance is provided in Section 6.6.

### 7.6.1 GENERAL

The General tab includes model run time controls. The start time should be set to time zero, and the end time should be set to ensure peak flows and stages are captured. For example, a simulation end time of 48 hours or more may be necessary for the 100-year 24-hour design storm.

The minimum and maximum calculation time steps should be assigned to be consistent with the time marching approach (Tolerance tab). Typically, the maximum calculation time should not exceed 60 seconds and depends on the routing time required for modeled conduits. The maximum allowed calculation time should not exceed the time required for a dynamic wave to pass through a modeled conduit during hydraulic routing.

### 7.6.2 OUTPUT TIME INCREMENTS

Time increments should be established to capture the flow and stage hydrograph peaks for all model elements and allow for effective quality control. Typically, Hydrology time increments should be set to 5 minutes. Surface Hydraulics time increments should be set to 5 minutes near the storm peak, typically near hour 12 of the simulation for a 24-hour design storm, but may be set to 15 minutes for the remaining simulation period. The Stormwater Division may use smaller time increments during the review process, such as 1 minute, to check model stability, and applicants are encouraged to proactively complete similar quality control measures.

### 7.6.3 RESOURCES AND LOOKUP TABLES

Typically, no Resources or Lookup Tables are required based on the modeling approach described in this Manual. Applicants are referred to the ICPR4 support documentation for additional details.

### 7.6.4 TOLERANCES AND OPTIONS

Tolerances and Options within the Simulation Manager should be set to the following:

- Time Marching should be set to SAOR.
- Maximum Iterations should be set to 6.
- Over-Relaxation Weighting Factor should be set to 0.5.
- dZ Tolerance should be set to 0.001 foot.
- Maximum dZ should be 1 foot or less.
- Link Optimizer Tolerance should be set to 0.0001 foot.
- Initial Abstraction Recovery Time should be set to 24 but should not be relevant based on the modeling approach described in this Manual.
- Simple/Manual Basin Rainfall Opt. should be set to Global.
- Rainfall Name should be set based on current SWFWMD guidance for each simulated design storm, currently FLMOD.
- Rainfall Amount should be set based on current SWFWMD guidance for each simulated design storm.

- Storm Duration should be set to 24 hours unless a different duration design storm is being simulated.
- Default Damping Threshold (1D) should be set to 0.005 foot.
- Minimum Node Surface Area (1D) should be set to 43.5 square feet.
- Energy Switch should be set to Use Link Selection.

The applicant should check that the model does not generate errors or warnings of concern at the startup of the run. Unlike ICPR3, a pop-up does not signal when warnings and/or errors occur. Figure 7.7 shows the Simulation Manager tab where a text file with a list of warnings and errors is created at startup for ICPR4.

**Figure 7.7 ICPR4 Simulation Manager GUI**

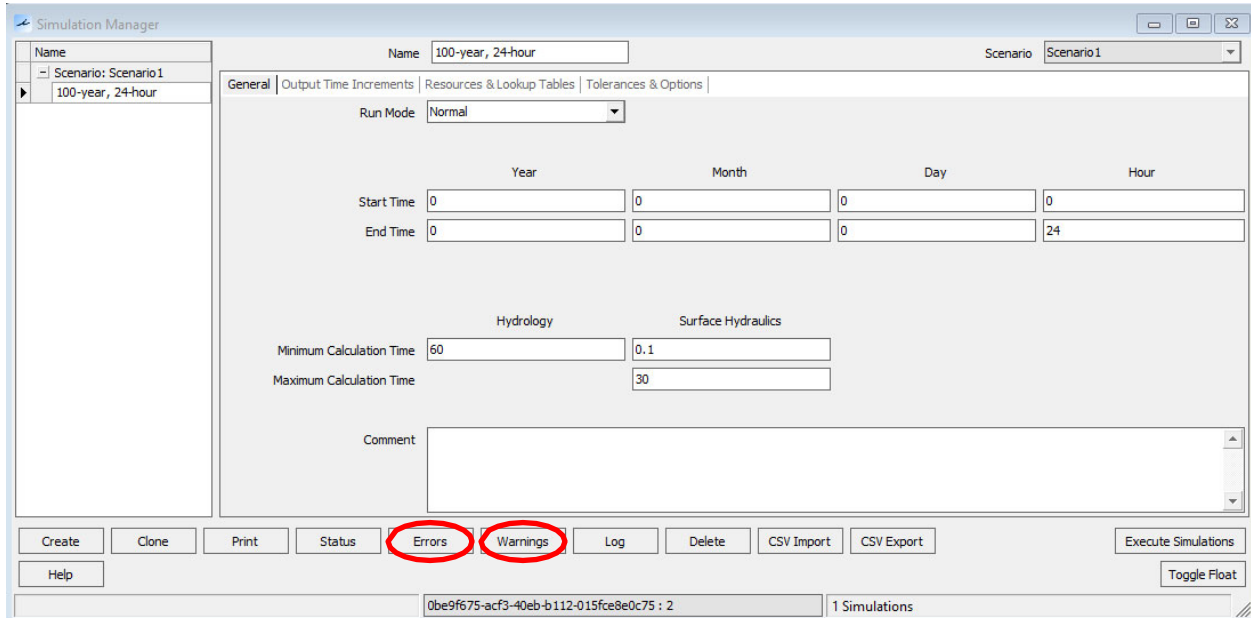

## 7.7 QUALITY CONTROL

A thorough quality assurance/quality control (QA/QC) process should be completed by the Engineer of Record for all stormwater models. **The Engineer of Record is fully responsible to complete QA/QC of all stormwater-related information included in the applicant submittals.**

To aid applicants, the Stormwater Division has provided quality control recommendations for ICPR4 models in Section 8.1. These recommendations include using two automated tools developed by the Stormwater Division that operate against ICPR4 model input data: ICPR4 Input Data Comparator and ICPR4 Input Data QC Tool. The results of the Comparator and QC Tool must be included in applicant submittals. The Stormwater Division provides these tools to applicants as a service, but **the Engineer of Record is expected to perform additional QA/QC** as warranted.

## 7.8 APPROACH-SPECIFIC SUBMITTAL REQUIREMENTS

In addition to the submittal requirements defined in Section 2.4, the following should be provided with submittals when the Model Incorporation Method is used for hydrologic design:

electronic copies of stormwater models, model-related spatial data, drawings and maps, and supporting calculations. More detail on these items is provided below. All submittal items should meet the standards established in Section 4.

### 7.8.1 STORMWATER MODELS

Submittals must include all stormwater model scenarios used for the stormwater design. Applicants should include the proposed stormwater management system drawings as a background image in ICPR4 to facilitate Stormwater Division review.

- The existing conditions model scenario must be provided even if no modifications were made to the County Basin Model.
- A revised existing conditions model scenario (if applicable) must be provided.
- A proposed conditions model scenario must be provided.

### 7.8.2 MODEL-RELATED SPATIAL DATA

Submittals should include spatial information related to stormwater models, maps, or supporting calculations. At a minimum, the following spatial data should be provided with each submittal:

- Model Schematic including Basin (polygons), Node (points), and Link (polylines) elements for each modeled condition: Revised Existing and Proposed.
- Model-Predicted Floodplains (polygons) for the 100-year 24-hour design storm for each modeled condition: Revised Existing and Proposed.
- Hydrologic Flow Paths (polylines) for Tc calculations within each basin and for each modeled condition. Each flow path should be segmented to show sheet, shallow concentrated, pipe, and channelized flow.
- Stage/Area (polygons) that represent the surface area of modeled nodal storage.
- Cross-Sections (polylines) that represent the ground location of cross-section data used in the model.
- Topographic information for each modeled condition: Revised Existing and Proposed.

### 7.8.3 MAPS

Submittals should include maps necessary to demonstrate compliance with criteria included in this Manual. At a minimum, the following should be provided with each submittal:

- A map or maps showing the revised existing condition model schematic including model basins, nodes, pipes, channels, cross-sections, drop structures, and weirs.
- A map or maps showing the proposed condition model schematic including model basins, nodes, pipes, channels, cross-sections, drop structures, and weirs.
- A map or maps showing hydrologic flow paths used to determine the Tc for each basin. The map should include basin boundaries with labels, model nodes, and the appropriate topography along with pertinent drainage features.
- A map or maps showing Stage/Area polygons used to develop nodal storage. The map should include basin boundaries with labels, model nodes, model channel links, and appropriate topography.
- A map or maps showing the revised existing condition floodplains.
- A map or maps showing the proposed condition floodplains.

#### 7.8.4 SUPPORTING CALCULATIONS AND SUMMARY TABLES

Submittals should include supporting calculations related to stormwater modeling and summary tables necessary to demonstrate compliance with criteria included in this Manual. At a minimum, the following should be provided with each submittal:

- Tc calculations as a spreadsheet.
- CN calculations as a spreadsheet.
- Stormwater treatment calculations to determine treatment volume and recovery time.
- Hydrologic and hydraulic calculations for stormwater management system features not explicitly included in the stormwater models.
- Summary tables to demonstrate compliance with County level-of-service criteria.
- Summary of model results for each modeled condition, including node peak stage and link peak flow.
- Results of the County's ICPR4 Input Data Comparator.
- Results of the County's ICPR4 Input Data QC Tool.



## 8 SUPPLEMENTAL TECHNICAL GUIDANCE

Additional guidance is provided in this section to supplement technical guidance provided in Sections 5 through 7. As with all technical guidance provided in this Manual, data development for the situations described in this section should be in accordance with standard engineering practices.

### 8.1 ICPR4 QUALITY CONTROL RECOMMENDATIONS

The quality assurance (QA)/quality control (QC) procedures highlighted below are the same procedures that the Stormwater Division uses to review submittals. The Engineer of Record has full responsibility to complete the QA/QC of all stormwater-related information included in applicant submittals, including the Interconnecting Channel and Pond Routing Version 4 (ICPR4) models.

#### 8.1.1 AUTOMATED CHECKS OF INPUT DATA

The Stormwater Division has created two automated tools that operate against ICPR4 model input data: ICPR4 Input Data Comparator and ICPR4 Input Data QC Tool. These tools are limited to input data checks and only support Simple Basin inputs. The tools do not check model results.

The ICPR4 Input Data Comparator compares input data from two models to determine data differences between the models. Applicants should use the Comparator to check model changes between modeled conditions, such as existing and proposed conditions. Attachment 12 provides additional documentation related to the Comparator. Results from the Comparator must be included in applicant submittals.

The ICPR4 Input Data QC Tool compares input data for compliance with standard modeling practice. Applicants should use the Tool to check that model input data are reasonable but should not rely on the QC Tool as the sole source of model QA/QC. Attachment 13 provides additional documentation related to the QC Tool. Results from the QC Tool must be included in applicant submittals.

#### 8.1.2 BACK-CHECK MODEL INPUT DATA

Model input data should be back-checked against the proposed stormwater management system included in drawings. Model parameters developed from supporting calculations or model-related spatial data should be checked to ensure that model parameters appropriately represent these data. Input data checks include, but are not limited to:

- Basin delineations for proposed conditions should match the grading shown in the survey and/or plans. Delineations should match information shown in the survey for all areas that are not being regraded.
- Basin areas should match area calculated from the model schematic basins.
- Basin parameters should match supporting calculations, such as curve number (CN) and time of concentration (Tc).
- Pipe, drop structure, and weir link dimensions; invert elevation; and material (roughness coefficient) should match the site survey for the existing conditions and the construction drawings for the proposed conditions.

### 8.1.3 MASS BALANCE

In general, model continuity is achieved when the change in storage volume equals inflow minus outflow. ICPR4 provides reports for hydrology and routing mass balance. For hydrology mass balance, reported precipitation and rainfall excess volumes should be checked to ensure that modeled volumes are representative of the expected rainfall- and runoff-response for the modeled area. For routing mass balance, the reported error percentage (%) should be reviewed for the duration of the simulation. The ICPR4 routing error % logic is provided below. Typically, maximum routing error % values should be below 1%. Larger error % values may be acceptable when total inflow is near zero.

$$\text{error \%} = \frac{\text{Flow Based Storage} - \text{Geometry Based Storage}}{\text{Total Inflow Volume}} \times 100$$

### 8.1.4 HYDROGRAPH STABILITY AND REASONABLENESS

In general, the model-predicted stage and flow should not oscillate or change quickly; in other words, stages and flows should be mathematically stable. Mathematical stability near peak stage and flow conditions is particularly important and will be a focal point of Stormwater Division reviews. All stage and flow hydrographs should be checked for model stability and reasonableness of predictions.

The Stormwater Division is unlikely to accept models that include significant instabilities. Applicants must provide a written explanation if stabilizing stage and flow hydrographs is not possible. This explanation should include the node and link names associated with the problem, a brief description of the issue, and the measures taken to try to remedy the instability.

### 8.1.5 PEAK STAGE AND FLOW REASONABLENESS

Peak flows and stages should be checked with respect to peak flows and stages of adjacent model elements. Significant outliers are an indicator of potentially suspect results. The model-predicted peak stage should be compared to established flood elevations if known.

The Stormwater Division is unlikely to accept models with unexplainable gains or losses in peak flows over short distances, models with large, unexplainable losses in stage across a single conduit, or models with predicted peak stage increasing upstream-to-downstream.

### 8.1.6 MODEL START-UP

All model conditions should initialize in a hydraulically static state, meaning no flows are present at time zero. In general, flow at the first time-step (time zero) indicates an improper initial condition and is not an acceptable modeling practice. This can be checked by reviewing link and node time series reports.

The Stormwater Division is unlikely to accept models that include significant initial flows. Applicants must provide a written explanation of non-zero flow at the first time-step.

### 8.1.7 MISSING INTERCONNECTIONS

Applicants should carefully review model results and associated floodplain maps for missing interconnections. The Stormwater Division does not accept models that include glass-walls,

which are no-flow boundaries where flow should be predicted. Glass-walls result in artificially increased upstream stage predictions due to the missing conveyance.

## 8.2 ICPR4 SCENARIOS

Within ICPR4, hydrologic and hydraulic input data and simulation controls are stored as unique scenarios. Every ICPR4 model must have at least one scenario. In other sections of this Manual, unique hydrologic and hydraulic calculations for different drainage conditions are referred to as a *model*, which is synonymous to the ICPR4 *scenario*. The ICPR4 support documentation provides additional discussion on scenario management.

Simplistically, applicants may use scenarios as follows:

- Hydrologic and hydraulic input data and simulation controls are completed for a base scenario, typically existing conditions.
- The base scenario is cloned to generate a new scenario, either revised existing conditions or proposed conditions.
- Hydrologic and hydraulic input data are modified as warranted for the new scenario. Simulation controls should not be modified.
- The clone process is repeated as necessary, such as existing condition to revised existing condition scenario and then revised existing condition to proposed condition scenario.

### 8.2.1 SUBSET EXTRACTION TOOL

Smaller model *subsets* can be extracted from an ICPR4 scenario by using the subset extraction tool. To extract a subset, applicants must graphically or manually select nodes that will be included and edited within the subset model from a scenario with completed results. During the extraction process, the completed scenario is copied as a backup and three new scenarios are generated: parent, subset, and boundary condition. The ICPR4 support documentation provides additional discussion on the subset extraction tool.

The subset scenario will include time-stage boundary conditions at adjoining node locations. For example, applicants can extract a subset scenario from a County Basin Model to establish boundary conditions for the submittal models. Applicants then only need to manage hydrologic and hydraulic input data for subset scenario. As with all submittal models, hydrologic and hydraulic input data must be updated in accordance with procedures outlined in this Manual.

### 8.2.2 DIFFERENCE TOOL

Differences between ICPR4 scenarios can be summarized to PDF or CSV files using the scenario difference tool. The tool can produce summaries that simply count scenario changes by model element or provide detailed comparisons of input data that changed as an addition, modification, or deletion. The ICPR4 support documentation provides additional discussion on the difference tool.

The Stormwater Division has created the ICPR4 Input Data Comparator to similarly report differences in input data. The Comparator results are documented in a format that better facilitates submittal review (Section 8.1).

## 8.3 SECONDARY STORMWATER MANAGEMENT SYSTEM CALCULATIONS

Hydraulic features that are not part of the primary stormwater management system do not need to be included in stormwater models, as discussed in Section 6.4 and 7.4. For stormwater pipe systems, secondary conveyance (internal pipe calculations) is where normal flow conditions may be assumed, and backwater conditions can be easily and adequately estimated. Stormwater inlets are typically considered to be part of the secondary stormwater management system since stormwater pipes are typically the controlling features in large storms.

All stormwater pipes and inlets must meet level-of-service standards detailed in the County's *Unified Development Code* (UDC) Article 18, Appendix C-14. Applicants must demonstrate compliance with level-of-service criteria in a summary table that includes internal pipe calculations (Section 3.3). The summary tables must provide sufficient information to satisfy reporting needs of UDC Article 18, Appendix C-26.

### 8.3.1 STORMWATER PIPES

For stormwater pipe systems not explicitly included in the applicant's stormwater models, hydrologic and hydraulic calculations must be completed using one of the following methods:

- A hydrodynamic stormwater model with the appropriate timed boundary condition applied at the outfall. The model must explicitly calculate the runoff rate and peak stage at each inlet.
- A spreadsheet model that determines the hydraulic grade line based on a prorated runoff rate from the stormwater model basin discharge. The spreadsheet must account for local losses and tailwater conditions at peak pipe inflow. Tailwater conditions must be based on the design high water level of proposed stormwater management facilities.
- A spreadsheet model that determines the hydraulic grade line based on a runoff rate derived using the Rational Method for each pipe segment. The spreadsheet must also account for local losses and tailwater conditions. Tailwater conditions must be based on the design high water level of proposed stormwater management facilities. This approach is discussed further in Section 5.

### 8.3.2 STORMWATER INLETS

Stormwater models typically assume inlets achieve an instantaneous 100-percent capture rate and ignore inlet limitations. Accordingly, stormwater inlet hydrologic and hydraulic calculations are typically performed outside of stormwater models. A spreadsheet analysis approach based on the Rational Method is discussed further in Section 5.

## 8.4 BRIDGE MODELING

Unlike ICPR3, the water-surface profile computation model *WSPRO* is no longer available within ICPR4 nor does ICPR4 provide for bridge links. Instead, bridges are commonly modeled within ICPR4 as rating curve links. The Stormwater Division recommends applicants develop tailwater-headwater-discharge curves for rating curve links that represent bridges using HEC-RAS. Bridge modeling in HEC-RAS should be consistent with USACE documentation and guidance. An example of developing tailwater-headwater-discharge curves for ICPR4 from HEC-RAS is available in the ICPR4 supporting documentation.

## 8.5 DRAWDOWN CALCULATIONS USING PERCOLATION LINKS

Applicants may choose to perform drawdown calculations using percolation links available in ICPR4. For drawdown calculations, the modeled stormwater pond stage should be initialized to appropriately represent the pond volume that is required for drawdown, commonly the full treatment volume, to show treatment recovery. Percolation links must be included to represent horizontal and vertical percolation occurring at the pond during recovery. The simulation time should be sufficient to capture full drawdown from the initial elevation to the pond bottom or to the required recovery period.

Typically, applicants will use site-specific geotechnical data to develop parameters for percolation links. In some cases, conservative values based on NRCS soil maps and Natural Resources Conservation Service (NRCS) Soil Survey Geographic Database (SSURGO) data may be acceptable.

## 8.6 TWO-DIMENSIONAL SURFACE ROUTING

ICPR4 is self-described by Streamline Technologies, Inc. as a one-dimensional stormwater model and a fully integrated two-dimensional surface water and groundwater flow model, with an emphasis on interactions between surficial aquifer systems and surface water bodies. For two-dimensional surface flows, ICPR4 allows users to model surface flows via a user-defined triangular mesh that operates against a surface elevation grid. This two-dimensional model approach is most warranted for areas where surface flows are ill-defined by typical hydraulic features and, therefore, traditional one-dimensional modeling approaches.

Typically, two-dimensional surface routing is not required to accurately represent a proposed stormwater management system. If the applicant thinks two-dimensional surface routing is required to accurately represent the project's stormwater management system, this should be discussed at the stormwater methodology meeting. As of the development of this Manual, **the Stormwater Division will not accept two-dimensional modeling for land development submittals.** One-dimensional stormwater model elements, like those included in ICPR4, have been developed specifically to address land development needs and are likely sufficient to accurately predict stages and flows from all components of the proposed stormwater management system.

## 8.7 LOW-IMPACT DEVELOPMENT AND GREEN INFRASTRUCTURE

The County encourages incorporating low-impact development (LID) and green infrastructure technologies into site designs and stormwater management systems. Typically, these design elements are only ancillary components of the stormwater management system during regulatory-level events such as the 100-year 24-hour design storm. Most of these technologies are designed to capture and treat flows from everyday rainfall events and by design quickly become overwhelmed in larger events.

Accordingly, these technologies typically do not require the development of unique stormwater model elements to accurately represent the proposed system for 100-year 24-hour design storm modeling. If the applicant thinks the proposed technology will significantly impact the stormwater system during larger storm events, the approach to incorporate these technologies into the stormwater model should be discussed at the stormwater methodology meeting.

For more information on LID and Green Infrastructure technologies, applicants are referred to the County's *LID Guidance Document*, which is available to download from the County's website. Included in the *LID Guidance Document* is permitting guidance that demonstrates how LID can be included into water quality treatment calculations.

## 8.8 ICPR3 MIGRATION TO ICPR4

As of the completion of this Manual, the Stormwater Division has begun migrating County Basin Models from ICPR3 to ICPR4. The Stormwater Division expects all County Basin Models will be ICPR4 models in the near future. The following guidance is offered to better understand applicant submittal requirements during the transitional period from ICPR3 to ICPR4 and to increase applicant understanding of ICPR4 changes from ICPR3. The Stormwater Division **strongly recommends applicants request a stormwater methodology meeting** to establish submittal requirements if ICPR model conversion is warranted.

### 8.8.1 DOES MY PROJECT REQUIRE ICPR4?

As of the completion of this Manual, the Stormwater Division will accept ICPR3 models on a case-by-case basis. In general, the Stormwater Division recommends applicants use ICPR4, since ICPR3 is no longer supported by Streamline Technologies. Once the Stormwater Division has completed the migration of all County Basin Models to ICPR4, ICPR3 will no longer be accepted as a hydrologic design tool.

### 8.8.2 CONVERTING ICPR3 TO ICPR4

In rare instances during this transitional period, applicants may need to convert existing ICPR3 models to ICPR4. **Applicants must coordinate the model conversion process and documentation with the Stormwater Division** if ICPR model conversion is warranted for a land development project. An overview of the conversion process required by the Stormwater Division is provided below.

#### 8.8.2.1 Model Import

ICPR4 allows for direct import of ICPR3 models. This topic is covered extensively in the ICPR4 support documentation with multiple examples. Of note, units are assigned at the creation of a new ICPR4 project file and cannot be changed afterward. The Stormwater Division requires models to be developed using English units. County Basin Models have been developed using English units.

Following an ICPR3 import, a log text file appears on the screen showing all features that were successfully imported during the conversion process. Any features that are missed or are no longer supported in ICPR4 (such as overland flow basins, exfiltration trench, and filter links) will show as being "skipped" in the completion log. Figure 8.1 shows a sample log file with zero skipped elements. ICPR3 model data is stored in ICPR4 within the *ICpr3* scenario.

Reviewing this text file to compare the number of model features between ICPR3 and ICPR4 is important to check the success of the import and identify additional data development needs for the ICPR4 model. Converted County Basin Models should not contain skipped features. If skipped features are encountered, these model elements should be reconciled on a case-by-case basis.

**Figure 8.1 Example ICPR3-to-ICPR4 Log File**

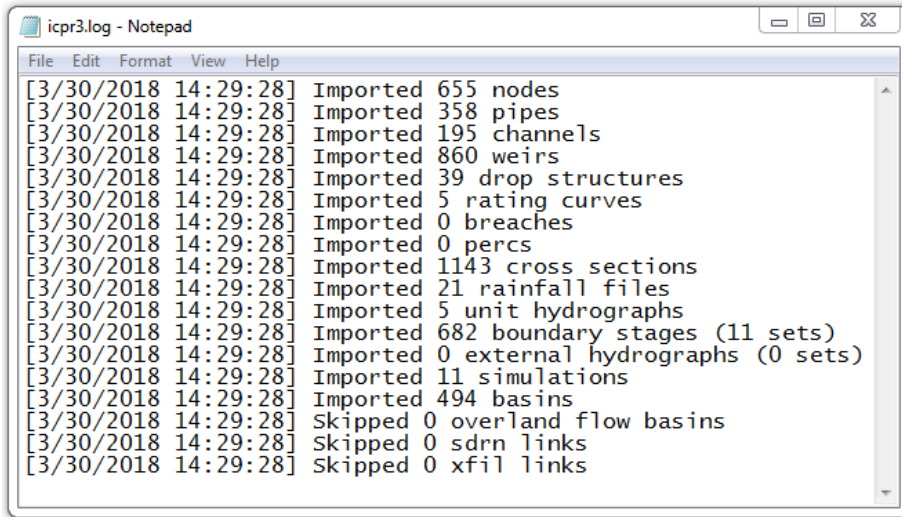

```

icpr3.log - Notepad
File Edit Format View Help
[3/30/2018 14:29:28] Imported 655 nodes
[3/30/2018 14:29:28] Imported 358 pipes
[3/30/2018 14:29:28] Imported 195 channels
[3/30/2018 14:29:28] Imported 860 weirs
[3/30/2018 14:29:28] Imported 39 drop structures
[3/30/2018 14:29:28] Imported 5 rating curves
[3/30/2018 14:29:28] Imported 0 breaches
[3/30/2018 14:29:28] Imported 0 percs
[3/30/2018 14:29:28] Imported 1143 cross sections
[3/30/2018 14:29:28] Imported 21 rainfall files
[3/30/2018 14:29:28] Imported 5 unit hydrographs
[3/30/2018 14:29:28] Imported 682 boundary stages (11 sets)
[3/30/2018 14:29:28] Imported 0 external hydrographs (0 sets)
[3/30/2018 14:29:28] Imported 11 simulations
[3/30/2018 14:29:28] Imported 494 basins
[3/30/2018 14:29:28] Skipped 0 overland flow basins
[3/30/2018 14:29:28] Skipped 0 sdrn links
[3/30/2018 14:29:28] Skipped 0 xfil links
  
```

### 8.8.2.2 Stormwater Division Requirements

Applicants are advised that the process for Stormwater Division acceptance of converted ICPR3 models is demanding. The information provided here is intended to inform the applicant of the process requirements and is not intended as a replacement for a stormwater methodology meeting to discuss these requirements. For County Basin Models, applicants must convert the ICPR3 model to ICPR4 and convert model-related geographic information system (GIS) data to the latest Southwest Florida Water Management District (SWFWMD) *Geographic Watershed Information System (GWIS)* geodatabase schema. An outline of the conversion process required by the County is provided as Attachment 14. At minimum, the following is required for Stormwater Division acceptance:

- Differences in node peak stage and link peak flow (ICPR3 vs. ICPR4) must be explicitly documented in a summary table.
- The applicant’s approach to reconcile changes to model elements during conversion and address model result differences must be documented in a summary report.
- The applicant must meet with the Stormwater Division to discuss the summary report.
- Depending on the magnitude of the result differences, the applicant may need to complete additional model verification by way of calibration of the ICPR4 model to one or more historical rainfall events.

Applicants must thoroughly review ICPR4 models generated from an existing ICPR3 model for consistency and accurate representation of the watershed. Most notably, ICPR3 model elements that include overland flow weirs assigned type *Paved* or *Gravel*, non-standard pipe dimensions, and node extrapolations should be reviewed in detail before and after conversion to ICPR4. Additional examples of differences between model version are provided in the subsections below. The Stormwater Division will make the final determinations on whether result differences are acceptable and if additional model verification is required.

### 8.8.3 PERTINENT DIFFERENCES BETWEEN ICPR4 AND ICPR3

Multiple differences exist between ICPR4 and ICPR3. These differences are covered extensively in the ICPR4 support documentation with only a brief overview of items pertinent

to the County Basin Models provided below to increase applicant understanding of ICPR4 changes from ICPR3. The items presented here are not an exhaustive list of differences between the model versions or of review items necessary following model conversion.

#### 8.8.3.1 Basin Parameters

ICPR4 supports different basin types depending on whether basin parameters are characterized within the ICPR4 framework or without. ICPR4's Manual Basin Data approach allows users to calculate basin parameters based on data layers and related tables within ICPR4. Applicants are referred to the ICPR4 support documentation for additional details on this approach. As of the development of this Manual, the Stormwater Division will not allow applicants to use the Manual Basin Data approach.

ICPR4's Simple Basin Data approach allows users to directly input basin parameters that have been developed outside of ICPR4 and is the default basin type when importing an ICPR3 model. The Simple Basin Data approach is the approach required by the Stormwater Division since it allows easy review of basin parameters.

#### 8.8.3.2 Node Extrapolations

In ICPR3, linear extrapolation of node storage would occur when water levels exceed the highest elevation in the stage-area table and the offending model elements would be recorded in node reports. However, extrapolation is not reported in ICPR4. In ICPR4, the last area reported in the stage-area table is used when water levels exceed the highest elevation reported in the table.

#### 8.8.3.3 Manhole Nodes

ICPR4 does not support node manhole types. Nodes that would have been classified as a manhole type in ICPR3 should be classified as stage-area type in ICPR4. Assignment of hydraulic losses for the node should correspondingly be updated. Minor differences in model results should be expected at node locations previously classified as manholes in ICPR3 following model conversion to ICPR4.

#### 8.8.3.4 Energy Switch for Channels and Culverts

The Energy Switch parameter in ICPR4 determines how flows in channels and pipes are calculated and allows the flow equation to be set for individual links if necessary. The default Energy Switch assignment is *Energy* when converting from an ICPR3 model.

Following initial runs of a converted model, all link hydrographs should be checked for numeric instabilities, and the Energy Switch parameter can be evaluated at the location of link instabilities as a potential solution. Applicants are referred to the ICPR4 support documentation for details on the different flow equations available. ICPR3 and ICPR4 options are compared below:

- ICPR3 used the energy equation for all channel and pipe flow calculations.
- ICPR4 provides three options for this parameter: the momentum equation (St. Venant Equations), the energy equation, and the diffusive wave equation.



### 8.8.3.5 Culvert Geometry

Although ICPR3 allowed users to input non-standard culvert geometries, ICPR4 has hard-coded standard pipe ratios. The hard-coding prevents ICPR4 from importing non-standard geometries modeled from ICPR3. Applicants must therefore replace the non-standard structures in ICPR3 that cannot be imported with a structure in ICPR4 that is similar hydraulically.

An example of a non-standard dimensionality is the arch culvert. Reviewing all arch culverts is important to determine the changes needed in ICPR4 to match previously modeled flows through these structures. Two potential examples include:

- Concrete culverts modeled as arch pipes. The ICPR4 pipe link geometry *Con Span* that uses a channel cross-section bottom with cross-section lid (or top) is an appropriate replacement element. Figure 8.2 shows a cross-section with bottom and top sections.
- Corrugated metal pipes modeled as arch pipes. The pipe geometry of *Arch Structural Plate* should be used to keep the original pipe dimensions used in ICPR3.

Another example of a non-standard dimensionality is the elliptical culvert. If an elliptical pipe in ICPR3 does not match the depth-width ratio hard-coded within ICPR4, a Manual analysis needs to be completed to determine the appropriate depth to be input into ICPR4 that will satisfy the ratio and will result in a similar flow area.

**Figure 8.2 Example ICPR4 Cross-Section with Bottom and Top**

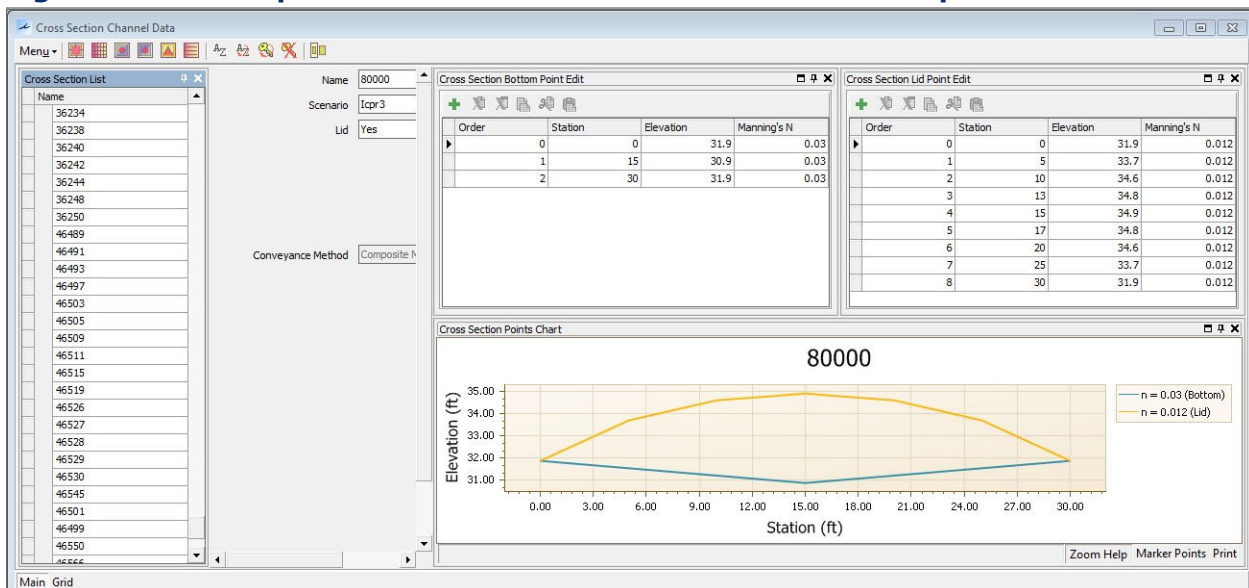

### 8.8.3.6 Drop Structures

A new feature in ICPR4 is the ability to change how hydraulic calculations are carried out in drop structure links. Two options are available: *Combine* and *Split*. Applicants are referred to the ICPR4 support documentation for additional details on each approach. In short:

- The *Combine* option is akin to drop structure hydraulic calculations in ICPR3, where the model uses an iterative solution to balance flow through the weirs and culverts.

- The *Split* option is more physically based and calculates the hydraulics of weirs and culverts separately, notably including pipe storage, and is expected to provide more accurate predictions of pipe velocity. The *Split* option is also expected to increase model simulation time.
- Both methods should produce similar results for flows under common hydraulic conditions.

Converted ICPR3 models default to the *Combine* option due to the similarity to ICPR3. Since the ICPR3 County Basin Models have previously been verified and accepted by the community, the Stormwater Division requires applicants use the *Combine* option in ICPR4 to maintain consistency with previous efforts. Applicants that want to use the *Split* option must provide documentation of the option's impact on model results, including peak stage and peak flow, and a narrative explanation of the necessity to use the *Split* option as part of the submittal. The Stormwater Division will not accept models using the *Split* option when significant differences are observed in the modeled peak stage or peak flow when compared to the *Combine* option.

#### 8.8.3.7 Bridges

Bridge links are not included within ICPR4. When converted, ICPR3 bridge link tailwater-headwater-discharge curves will become an ICPR4 rating curve link. Tailwater-headwater-discharge curves should be reviewed to ensure ICPR4 simulations will proceed without error. Modifications to tailwater-headwater-discharge curves from ICPR3 may be necessary. Additional discussion of ICPR4 bridge modeling is provided in Section 8.5.

#### 8.8.3.8 Overland Flow Weirs

Each of the five weir type options from ICPR3 is still available in ICPR4 with all underlying equations the same between the two versions. However, isolated cases of link instabilities have been observed for links using the *Paved* or *Gravel* weir type in ICPR4 that were not present in ICPR3. Changing the weir link type to *Broad Crested* generally provides a more stable result. All *Paved* or *Gravel* weir link types should be reviewed following conversion.

#### 8.8.3.9 Simulation Manager

Within ICPR4, hydrologic and hydraulic routing control information is stored within the Simulation Manager. The setup of the Simulation Manager is notably different from similar solution controls in ICPR3. Applicants are referred to Section 7.6 and the ICPR4 support documentation for additional details on the Simulation Manager.

#### 8.8.3.10 Scenario Manager

Within ICPR4, hydrologic and hydraulic input data and simulation controls are stored as unique scenarios. This functionality was not available in ICPR3 and applicants are advised scenarios are not equivalent to ICPR3 groups. Applicants are referred to Section 8.2 and the ICPR4 support documentation for additional details on ICPR4 scenarios.

# CHAPTER 4

## REFERENCES AND ATTACHMENTS



## 9 REFERENCES

- FDOT Office of Design. 2020. *Drainage Design Guide*. State of Florida Department of Transportation. January 2020.
- FDOT Office of Design. 2020. *Drainage Manual*. State of Florida Department of Transportation. January 2020.
- Federal Emergency Management Agency. 2019. Guidance for Flood Risk Analysis and Mapping. Floodway Analysis and Mapping. Guidance Document 79. November 2019.
- Federal Highway Administration. 2012. *Hydraulic Design of Highway Culverts, Third Edition*. Hydraulic Design Series Number 5. Publication No. FHWA-HIF-12-026. April 2012.
- Federal Highway Administration. 2013. *Urban Drainage Design Manual*. Hydraulic Engineering Circular No. 22, Third Edition. Publication No. FHWA-NHI-10-009. September 2009. Revised August 2013.
- Kimley-Horn and Associates, Inc. 2005. *Sarasota County Watersheds Floodplain Model Methodology Report*. 2005.
- Natural Resources Conservation Service (NRCS). 1999. *Urban Hydrology for Small Watersheds. Technical Release 55*. June 1986. Updated January 1999.
- Sarasota County. 2006. *Stormwater Manual for Site, Development, Subdivision, and Capital Improvement Projects Review Submittals*. October 2006.
- Southwest Florida Water Management District (SWFWMD). 2018. *Environmental Resource Permit Applicant's Handbook Volume I*. June 2018.
- Southwest Florida Water Management District (SWFWMD). 2018. *Environmental Resource Permit Applicant's Handbook Volume II*. June 2018.
- Southwest Florida Water Management District (SWFWMD). 2011. *Environmental Resource Permit Information Manual*. December 2011.
- Streamline Technologies, Inc. 2018. *ICPR4 Technical Reference*. June 2018.

**Attachment 1**  
**Earthmoving Permit Application Form**

Attachment  
**APPLICATION SUBMITTAL REQUIREMENTS**

**GENERAL, MINOR, MAJOR, and all permit applications, except for Conceptual Permits,** should provide the following in accordance with Appendix I, Article XII, Sarasota County Code:

1.        **Original and one copy of the application,** pages 1 and 2, complete, signed and notarized.
2.        **Non-refundable application fees. See Attachment 3, for schedule of fees.** Amount of fee provided: \$ \_\_\_\_\_
3.        **For permit applications, complete Attachment 1, Bond Authorization,** and provide performance bond. (Check, Money Order or Letter or Credit) in accordance with Sections 54-350.
4.        **Vicinity map** showing relation of the site to be permitted to nearby roadways.
5.        **Aerial photograph** (scale: 1 inch== 200 feet or less), *three* copies of the most recent available with the parcel boundaries clearly identified.
6.        **Site plan,** original and three copies, showing the following:
  - a.        Boundaries of the site to be permitted;
  - b.        Map scale;
  - c.        North arrow;
  - d.        A site boundary and topographical survey clearly showing existing and proposed elevations, existing site features, easements, and rights-of ways;
  - e.        Proposed location(s) for excavation and/or disposition of fill;
  - f.        Cross-section of fill and stockpile areas;
  - g.        Location of wetlands and applicable buffers, if any, and other native habitats;
  - h.        Proposed method(s) to control erosion including stabilization of excavated side slopes, filled and stockpiled areas (complete Item 3e., page 1 of the Application);
  - i.        On-site and adjacent off-site stormwater flow patterns for existing and proposed conditions;
  - j.        Proposed culverts and dimensions (length, diameter, inverts);
  - k.        Area of land disturbance. (see No. 8., page 6 of Attachment 2)

***PROVIDE THE FOLLOWING ONLY IF APPLICABLE TO YOUR PROJECT:***

**FOR EXCAVATIONS:**

- l.        Proposed slopes (refer to Section 54-347(3) and complete Attachment 5, Cross Section of Excavation;
- m.        Proposed setbacks from abutting property lines (refer to Section 54-347(1));
- n.        Method of dewatering and on-site retention (complete Item 3d., page 1 of the Application);
- o.        Locations of underground storage tanks, septic tanks and drain fields;
- p.        Locations of wells on-site, including the number and specific type (e.g. public supply, domestic, agricultural, irrigation, monitoring)

**FOR PROPOSED ALLS WITHIN 100 VEAR FLOODPLAINS:**

- q.        A compensation plan (refer to the Subdivision Technical Manual of the County's Land Development Regulations);

**FOR PROPOSED EARTHMOVING INVOLVING WETLAND IMPACTS:**

- r.        A wetland mitigation, monitoring, and maintenance plan if wetland impacts are proposed (also refer to the Environmental Technical Manual of the County's Land Development Regulations);
- s.        A Date of the pre-application meeting with Environmental Permitting: \_\_\_\_\_

7.        A littoral zone plan if any proposed excavation is greater than one acre in size (also refer to Sections 54-347(7) and 54-347(8)).
8.        A hydroperiod maintenance plan if wetlands are on-site (also refer to the Environmental Technical Manual of the County's Land Development Regulations).

**FOR PROPOSED EARTHMOVING WHERE TREES EXIST ON SITE:** As an option, a combined tree removal and earthmoving permit may be requested. Please provide the following information in accordance with Chapter 54, Article XVIII, Sarasota County Code:

9.        Application for a Tree Removal & Protection Permit, complete and signed. See Attachment 6.
10.        A tree location survey, printed on the site plan.
11.        Application fee. See Attachment 3 for schedule of fees. Amount provided: \$ \_\_\_\_\_

**MAJOR permit applications** (more than 10,000 cubic yards of Type A fill or earthmoving involving Type B or C fill), should provide the following additional information in accordance with Appendix I, Sarasota County Code:

1. **Site plan** (scale: 1 inch = 200 feet or less) prepared, signed, and sealed by a Florida Registered Engineer. For Level III permit applications (more than 100,000 cubic yards of Type A fill or more than 50,000 cubic yards of Type B or C fill), a 8 1/2" x 11" reproducible copy (not to scale) is to be submitted for inclusion into the Board packets.
2. **Preliminary closure plan** and reclamation cost breakdown certified by a Florida Registered Engineer (refer to Sections 54-3346(1)(c),(d),(e); 54-350; 54-345(6)(b); 54-345(10); 54-347(3); 54-347(6); 54-347(7); 54-347(8); 54-347(9); 54-348(3); 54-348(1)(c); 54-343(3)(e); 54-348(a)(5); and 54-352(a)).
3. **Reclamation bond** in accordance with Sections 54-350 (obtain a separate Performance and Reclamation Surety bond form from the Environmental Permitting office).  
Amount of reclamation bond provided: \$ \_\_\_\_\_
4. **For Level III applications only**, a report demonstrating compliance with any master plan approved as part of a conceptual permit approval.

**FOR HAULING:**

5. Identification of a designated haul route.
6. Evidence of existing road conditions along a designated haul route including photographs or video tape.
7. Destination(s) of material to be transported.
8. **For Level III applications only** (more than 100,000 cubic yards of Type A fill or more than 50,000 cubic yards of Type B or C fill to be removed off-site):
  - a. Date of the pre-application meeting with the Land Development Services: .....
  - b. **A Roadway Performance Bond** in accordance with Sections 54-350(d) (**see Attachment 1: Bond Authorization**). Amount of roadway performance bond provided:  
\$ \_\_\_\_\_

**FOR EXCAVATION:**

9. Test borings (to a minimum depth of 20 feet) showing the seasonal high water table and type of materials to the depth of the proposed excavation.
10. Locations of all water wells within 500 feet of the edge of the proposed excavation.

**FOR EXCAVATIONS WHERE DEWATERING MAY OCCUR WITHIN 200 FEET OF A WETLAND FOR A PERIOD GREATER THAN 30 DAYS:**

11. Area of groundwater drawdown (refer to Section 54-347(1)(d)).

**CONCEPTUAL PERMIT APPLICATIONS** (more than 100,000 cubic yards of Type A fill or more than 50,000 cubic yards of Type B or C fill), please provide the following information in accordance with Appendix I, Article XII of the Sarasota County Code:

1. The original and four copies of the application, pages 1 and 2, complete, signed and notarized.
2. A vicinity map showing relation of the site to be permitted to nearby roadways.
3. Three copies of the most recent available aerial photograph (scale: 1 inch= 200 feet or less) with the parcel boundaries clearly identified.
4. The original and three copies of a master site plan showing the following:
  - a. Proposed location(s) for excavation and/or disposition of fill;
  - b. Location of wetlands, if any, and other native habitats.
5. Evidence of existing road conditions along a designated haul route, if applicable.
6. **For hauling more than 100,000 cubic yards of Type A fill or more than 50,000 cubic yards of Type B or C fill only:**
  - a. Date of the pre-application meeting with Land Development Services office \_\_\_\_\_
7. A non-refundable application fee. See Attachment 3, for schedule of fees.  
Amount of fee provided: \$ \_\_\_\_\_

**PUBLIC HEARING ITEMS.** For Conceptual Permit Applications and Major Permit Applications without prior Conceptual Permit Approval, and variances, please provide the following information in accordance with Section 54-345(4) of the Sarasota County Code.

1. \_\_\_\_\_ A list and corresponding graphical location of all property owners to be notified pursuant to Section 54-345(4)(a)(1) and 54-345(4)(a)(2), shall be provided at the time of application. The most recent data available at the Property Appraisers Office should be utilized to develop this list.
2. \_\_\_\_\_ Aerial photo showing the location of each property meeting the notification criteria of Section 54-345(4)(a)(1). This aerial photo should show the name of each property owner, the street address of each property, and the approximate boundaries of the properties. A list attached to the aerial photo with a key identifying and locating the properties will be accepted.

### **ADDITIONAL REQUIREMENTS**

1. **APPLICATION AND BONO FEES:** Make all checks or money orders payable to Sarasota Board of County Commissioners. Application and bond fees can be submitted in one or two separate checks.
2. **PERFORMANCE AND RECLAMATION BONDS** can be provided in cash, Surety Bonds or Letters of Credit in the official form approved by Environmental Permitting and the Sarasota County Office of the County Attorney (sample forms are available at the Environmental Permitting office).
3. **ADVERTISING AND MAILING FEES** will be billed to the applicant and must be paid prior to the public hearing.
4. For projects that occur in areas with known significant historic resources or in areas with a moderate to high probability for the presence of significant historic resources based upon review of the County's History Center Database or other information available, a site assessment survey may be required by the County's History Center, in accordance with Ordinance No. 95-050, Section 66, Article III, of the Sarasota County Code. For more information, please contact the History Center at (941) 861-1180.
5. For projects containing on-site wetlands or other protected native habitats, the applicant may need to hire an environmental consultant to delineate the boundaries of the protected habitat(s). These boundaries would then be field verified by the appropriate State or County regulatory agencies. For more information, please contact the Environmental Permitting office at (941) 861-5000.
6. For projects where protected listed species may be present, the applicant may need to hire an environmental consultants and/or coordinate with the appropriate wildlife agencies regarding protection of the species. For more information, contact the U.S. Fish & Wildlife Service and/or the Florida Fish and Wildlife Conservation Commission.
7. The Natural Resource Conservation Service may be contacted for technical advice on pond design, erosion and sedimentation control at (941) 316-1100.
8. Projects disturbing more than one acre of land, or less than 1 acre of land if part of a larger common plan of development, are required to obtain National Pollutant Discharge Elimination (NPDES) coverage under the state Generic Permit for Stormwater Discharge from large and Small Construction Activities. Specific information about the requirements can be found on the Florida department of Environmental Protection website at: <http://www.dep.state.fl.us/water/stormwater/npdes/construction1.htm>. Sarasota County Water Resources requires the submittal of a copy of the completed Notice of Intent (NOI), and a copy of the Stormwater Pollution Prevention Plan (SWPPP) as outlined in Rule 62-621.300(4)(a), F.A.C.
9. Please be aware that other information may be requested by staff to assist in their review of the project, in accordance with Appendix I, Sections (2) t and (5)k of the Sarasota County Code.

**For additional information contact:**

**Environmental Protection Division- ENVIRONMENTAL PERMITTING**

1001 Sarasota Center Blvd., Sarasota, FL 34240 \* Phone: (941) 861-5000 \* Fax (941) 861-6267



**CROSS SECTION OF EXCAVATION**  
**PLEASE FILL IN REQUIRED**  
**INFORMATION**

DRAWING NOT TO SCALE

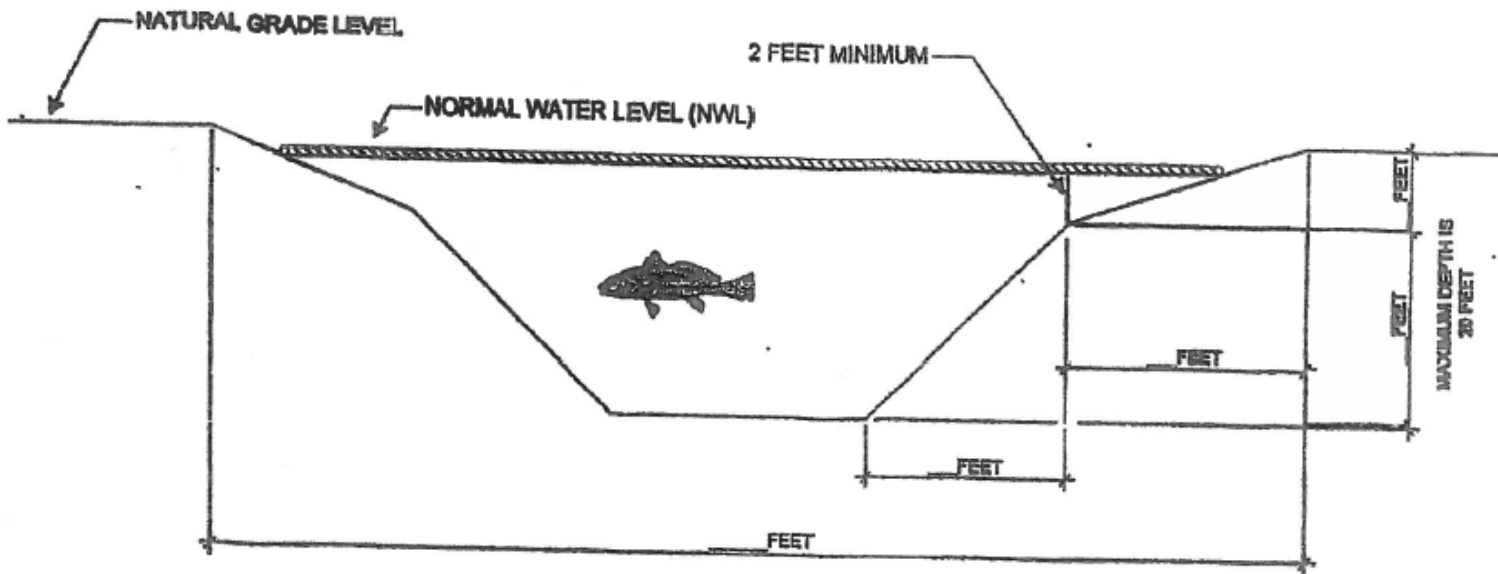

PLEASE INDICATE HOW NORMAL WATER LEVEL WAS DETERMINED:

\_\_\_\_\_

\_\_\_\_\_

\_\_\_\_\_

SLOPE FROM NORMAL GRADE TO 2 FEET BELOW NWL MUST BE NO GREATER THAN 4:1 (horizontal to vertical).  
 SLOPE FROM 2 FEET BELOW NWL TO BOTTOM MUST BE NO GREATER THAN 2:1 (horizontal to vertical).  
 PLEASE NOTE THAT SLOPES MAY BE MORE GRADUAL IF DESIRED.

ATTACHMENT 5

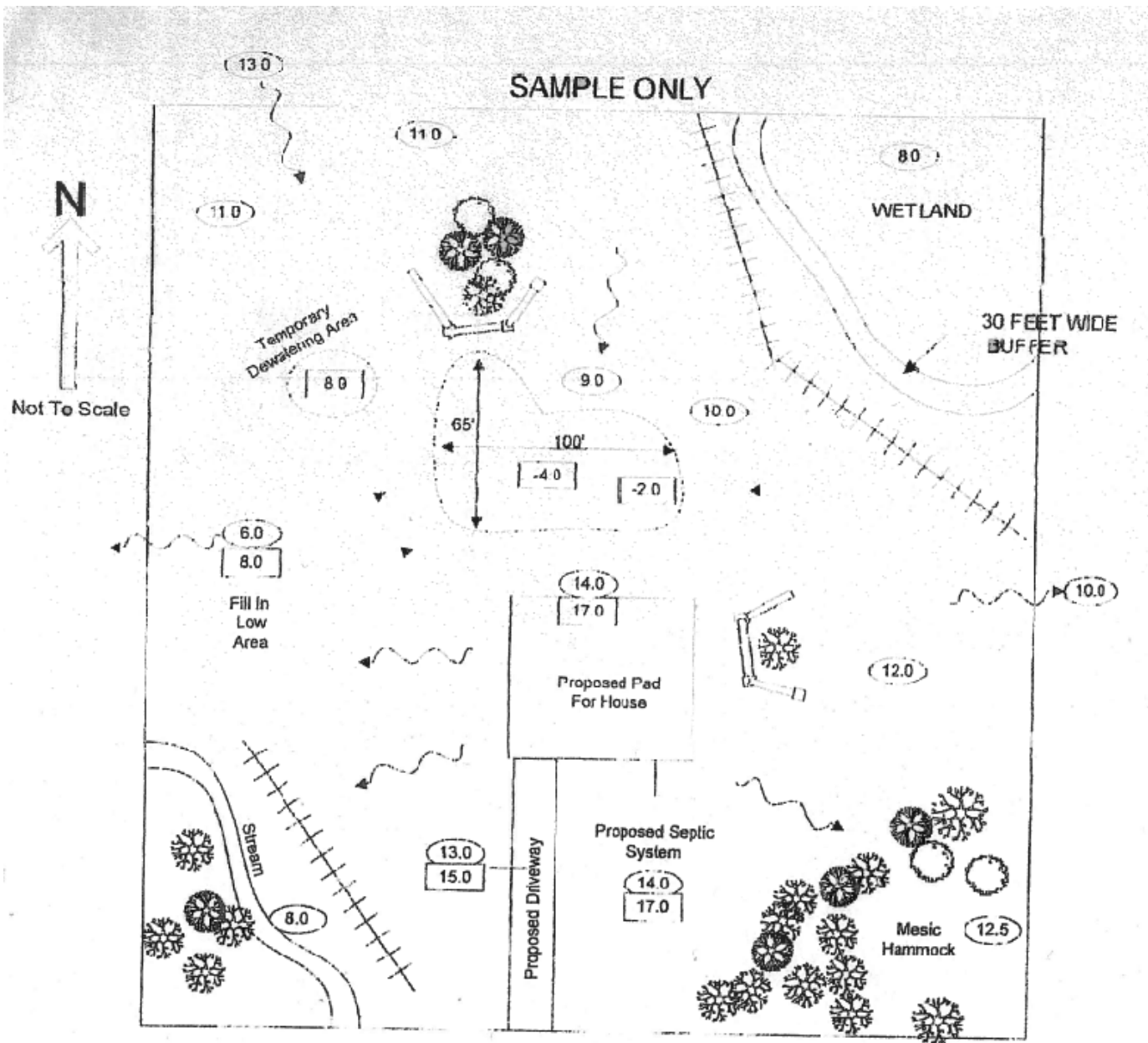

**LEGEND:**

Approximate Elevations (feet above sea level)	0.0 existing	General Flow Pattern	Existing	Proposed
	0.0 proposed	Silt screens		Tree Barricades
		Tree Line		

**CHECKLIST:**

- Activity is at least 30 feet from the jurisdictional boundary of wetland(s) and/or hardwood swamp(s).
- If wetland/hardwood swamp is surrounded by a mesic hammock, any activity is at least 50 feet from the jurisdictional boundary of wetland(s) and/or hardwood swamp(s).
- Excavation is a minimum of 50 feet from the property boundary.
- Septic tank is more than 100 feet from any wetland and/or excavation.

**Attachment 2**

**UDC Article 18 Appendices:  
Stormwater Review Checklists and  
Summary Forms**

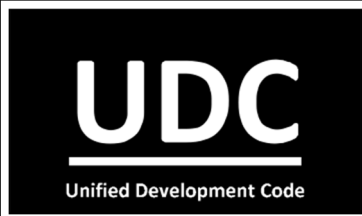

# SARASOTA COUNTY UNIFIED DEVELOPMENT CODE

ADOPTED BY ORDINANCE No. 2018-047 ON NOVEMBER 27, 2018 AS

CHAPTER 124 OF THE SARASOTA COUNTY CODE OF ORDINANCES

EFFECTIVE DATE JANUARY 1, 2019

## APPENDIX C24 -SUBDIVISION PLAT AND SITE DEVELOPMENT PLAN STORMWATER REVIEW CHECKLIST

PROJECT NAME:		
ITEM NO.	ITEM	CHECK ITEM IF PROVIDED
1	Site Area and Topographic Map/Total Area	
2	Show Offsite Drainage/Proposed Plan Route and Outfall Location	
3	Show Onsite Drainage and Easements/R.O.W., Drainage Basins and Critical Restrictions	
4	Provide Predeveloped Discharge Calculations/Critical Discharge Restrictions (i.e., Restrictions From Basin Master Drainage Plan)	
5	Provide Stormwater Treatment Volume Requirements	
6	Illustrate Proposed and Existing Offsite Easements	
7	Provide FEMA Floodplain Elevation/Delineation and Floodway Elevation/Delineation	
8	Seasonal High Water Elevation (SHWL)	
9	Conceptual Development Plan (show phasing)	

ALL ITEMS NOTED ABOVE MUST BE SUBMITTED FOR THE COUNTY TO ACCEPT THE SUBMITTAL.

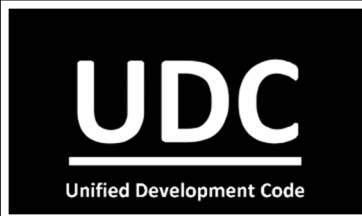

# SARASOTA COUNTY UNIFIED DEVELOPMENT CODE

ADOPTED BY ORDINANCE No. 2018-047 ON NOVEMBER 27, 2018 AS

CHAPTER 124 OF THE SARASOTA COUNTY CODE OF ORDINANCES

EFFECTIVE DATE JANUARY 1, 2019

## APPENDIX C25 – CONSTRUCTION PLAN STORMWATER REVIEW CHECKLIST

PROJECT NAME: _____		
ITEM NO.	ITEM	CHECK ITEM IF PROVIDED
1	Construction Plan Stormwater Design Summary Form Completed	
2	Detailed Design Calculations For Stormwater Management Systems	
3	Detailed Design Calculations For Site Stormwater Piping And Conveyance System	
4	Detailed Development Plans	
5	Final Easement (Onsite and Offsite)	
6	Ditch Cross Sections	
7	Lot Grading Plan And Cross Sections	
8	Finished Floor Elevations	
9	Illustrate Flood Encroachment And Compensation Areas	

ALL ITEMS ABOVE MUST BE SUBMITTED FOR THE COUNTY TO ACCEPT THE SUBMITTAL.

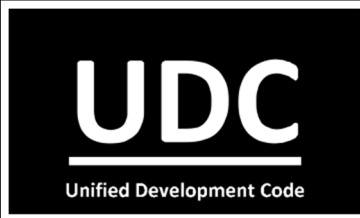

# SARASOTA COUNTY UNIFIED DEVELOPMENT CODE

ADOPTED BY ORDINANCE No. 2018-047 ON NOVEMBER 27, 2018 AS  
 CHAPTER 124 OF THE SARASOTA COUNTY CODE OF ORDINANCES  
 EFFECTIVE DATE JANUARY 1, 2019

## APPENDIX C26a. CONSTRUCTION PLAN STORMWATER DESIGN SUMMARY FORM

PROJECT NAME: \_\_\_\_\_

Engineer's Seal and Dated Signature

Section 124-252—DESIGN SUMMARY				
Total Site Area (Acres)				
Total Site Impervious (Acres)				
Survey Datum				
Stormwater Management System/Facility				
Drainage Basin Area (Acres)				
Drainage Basin Impervious (Acres)				
Seasonal High-Water Elevation				
Control Structure Control Elevation				
Method of Attenuation Calculation:	Rational:	<input type="checkbox"/>	Hydrograph Routing:	<input type="checkbox"/>
Rational or Hydrograph routing			No Adverse Impacts	<input type="checkbox"/>
Existing critical discharge requirements				
	10-YEAR	25-YEAR	100-YEAR	
Design High Water Elevation				
Storage Volume (Ac.-Ft)				
Pond Area (Acres)				
Pre-development Peak Discharge				
Post-development Peak Discharge				
Lowest Habitable Structure Elevation				
Treatment Volume Requirement				
Treatment Volume Provided				
Treatment Volume Type				
Attenuation Volume Drawdown Time (hrs)				
Treatment Volume Drawdown Time (hrs)				
1.5× Treatment Volume for discharge into in saltwater tidal systems	Yes: <input type="checkbox"/>	Not Applicable: <input type="checkbox"/>		
SWFWMD Permit Number and Expiration date	Number:	Expiration Date:		
NPDES (NOI) Application Form	Yes (provided):	Pending (to be applied for):	Not Applicable: <input type="checkbox"/>	

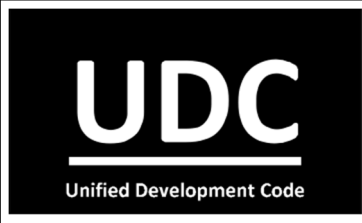

# SARASOTA COUNTY UNIFIED DEVELOPMENT CODE

ADOPTED BY ORDINANCE No. 2018-047 ON NOVEMBER 27, 2018 AS

CHAPTER 124 OF THE SARASOTA COUNTY CODE OF ORDINANCES

EFFECTIVE DATE JANUARY 1, 2019

Level of Service (LOS) Appendix C14 ROADWAYS	PROPOSED FLOODING VS. ALLOWABLE FLOODING					
	10-YEAR		25-YEAR		100-YEAR	
	Proposed	Allowable	Proposed	Allowable	Proposed	Allowable
Evacuation		0 inches		0 inches		0 inches
Arterial		0 inches		0 inches		6 inches
Collector		0 inches		6 inches		9 inches
Neighborhood		6 inches		9 inches		12 inches
Parking Area		9 inches		9 inches		12 inches

			FLOODPLAIN COMPENSATION	
Elevation		100-Year Floodplain Encroachment (cubic feet)	100-Year Floodplain Compensation (cubic feet)	
from	to			
Total				

TASK	PLAN FOR OPERATING AND MAINTAINING THE STORMWATER MANAGEMENT SYSTEM	
	FREQUENCY OF INSPECTION	FREQUENCY OF MAINTENANCE
1. Mowing and invasive plant species removal		
2. Stabilization of eroded bank areas		
3. Litter and debris removal		
4. Backflush underdrains (where applicable)		
5. Sediment removal and disposal		
6. Control Structure inspection and maintenance		
7. Permeability Testing		

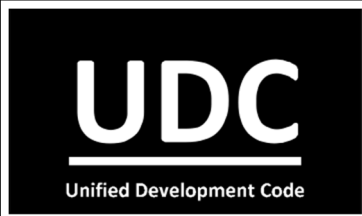

# SARASOTA COUNTY UNIFIED DEVELOPMENT CODE

ADOPTED BY ORDINANCE No. 2018-047 ON NOVEMBER 27, 2018 AS

CHAPTER 124 OF THE SARASOTA COUNTY CODE OF ORDINANCES

EFFECTIVE DATE JANUARY 1, 2019

## APPENDIX C26b - CONSTRUCTION PLAN STORMWATER DESIGN SUMMARY FORM FOR NET IMPROVEMENT

PROJECT NAME:	_____	Engineer's Seal and Dated Signature
WATERSHED/WATER BODY:	_____	
WBID:	_____	
IMPAIRED FOR:	_____	

Identify below the applicable assessed and reported watershed impairments or other pollutant source. Then demonstrate how this project will be providing additional water quality management by reducing the discharge of pollutants.

### NET IMPROVEMENT

TYPE	Pre-Development	Post-Development
<input type="checkbox"/> Chlorophyll-a		
<input type="checkbox"/> Copper		
<input type="checkbox"/> Fecal Coliform		
<input type="checkbox"/> Impervious Area		
<input type="checkbox"/> Iron		
<input type="checkbox"/> Mean Annual Runoff		
<input type="checkbox"/> Mercury		



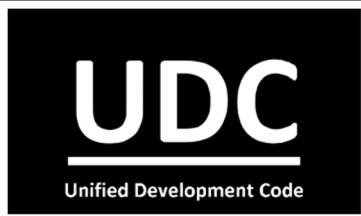

# SARASOTA COUNTY UNIFIED DEVELOPMENT CODE

ADOPTED BY ORDINANCE No. 2018-047 ON NOVEMBER 27, 2018 AS  
 CHAPTER 124 OF THE SARASOTA COUNTY CODE OF ORDINANCES  
 EFFECTIVE DATE JANUARY 1, 2019

<input type="checkbox"/> Nitrogen		
<input type="checkbox"/> Phosphorus		
Other:		
<input type="checkbox"/>		
<input type="checkbox"/>		
<input type="checkbox"/>		
<input type="checkbox"/>		
ADDITIONAL INFORMATION:		

**Attachment 3**

**UDC Article 18 Appendices:  
Stormwater Design Criteria**

### APPENDIX C13a -MINIMUM DESIGN STANDARDS FOR PONDS, LAKES AND WET/DRY RETENTION BASINS

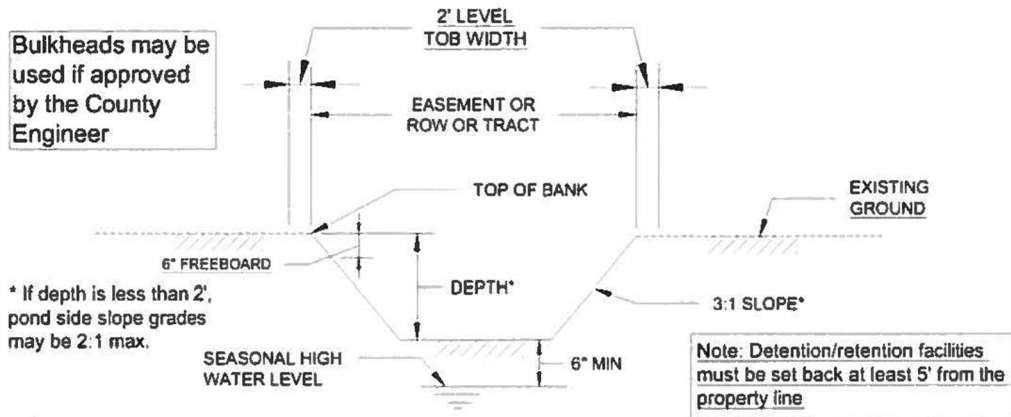

Note: Detention/retention facilities must be set back at least 5' from the property line

#### DRY RETENTION AREAS

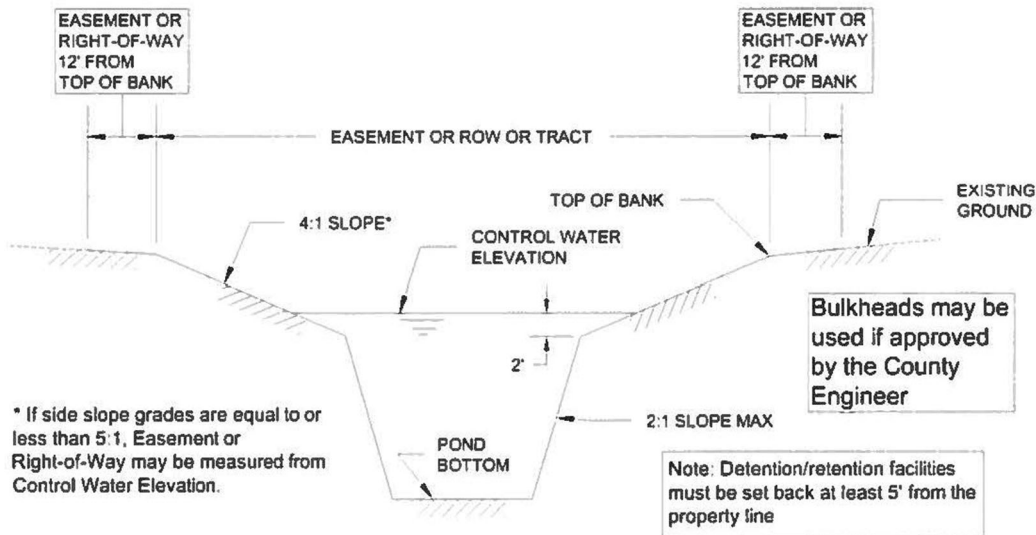

#### PONDS, LAKES AND WET RETENTION AREAS

### APPENDIX C13b -MINIMUM DESIGN STANDARDS FOR PONDS, DITCHES, CHANNELS AND SWALES

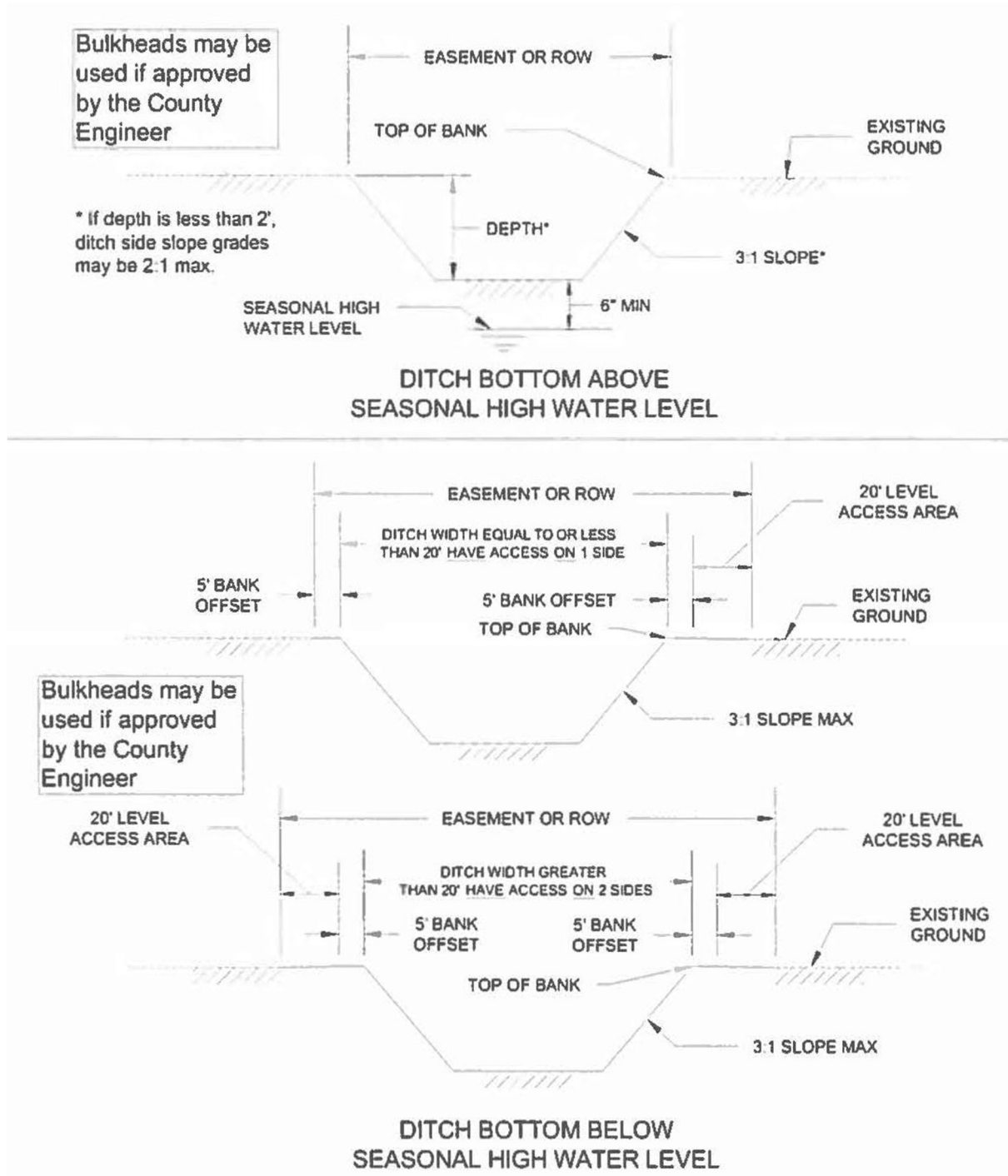

### APPENDIX C13c-MINIMUM DESIGN STANDARDS FOR SHALLOW BIORETENTION AND DETENTION WITH BIOFILTRATION

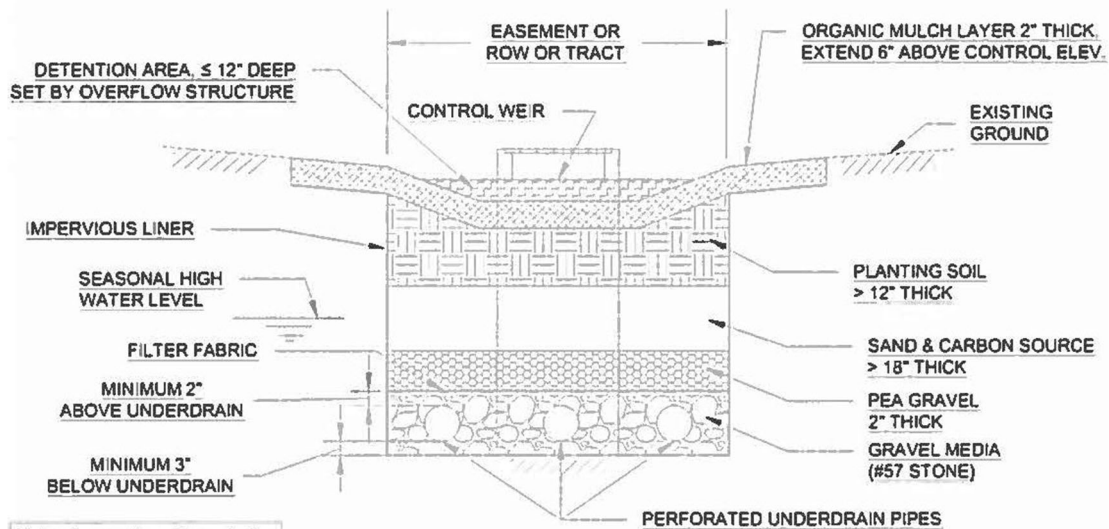
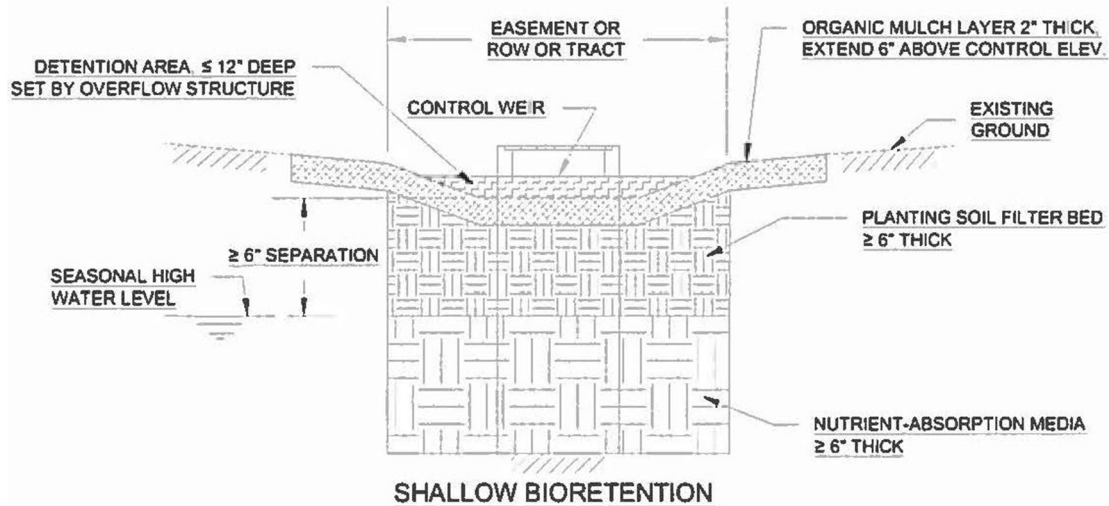

**Note:** Impervious liner shall have 6" of cover between it and the top of the organic mulch layer.

## APPENDIX C14 - STORMWATER QUANTITY LEVEL OF SERVICE AND DESIGN CRITERIA

	Flooding Reference (buildings, road and sites)	Level of Service (flood intervals are in years)
I.	Buildings: Pre-FIRM or Post-FIRM structures are at or above the flood water elevation.	
A.	Emergency shelters and essential services	> 100
B.	Habitable	100
C.	Employment/Service centers	100
II.	Road Access: Roads shall be possible during flooding. Roadway flooding < 6" depth at the outside edge of pavement is considered passable.	
A.	Evacuation	> 100
B.	Arterials	100
C.	Collectors	25
D.	Neighborhood	10
111.	Sites: Flooding refers to standing water in agricultural land, developed open or green space (yards and parking lots, etc.) and undeveloped lands designated for future development. This does not include areas incorporated into the stormwater or Basin Master Plan as flow ways, floodplain, or flood storage areas.	
A.	Urban (>1 unit/acre)	5
B.	Rural	2
IV.	The water quantity level of service can be adjusted to allow for greater amounts of flooding of roads and sites if the flooding is provided for in a Basin Master Plan or as part of a stormwater management system design and does not adversely impact public health and safety, natural resources or property. Attenuation Calculations will be based only upon the volume available in the detention/retention ponds or wetlands. The level of service for improvements to existing roadways may be adjusted based on existing conditions such as adjacent topography and economic impacts.	



# SARASOTA COUNTY UNIFIED DEVELOPMENT CODE

ADOPTED BY ORDINANCE No. 2018-047 ON NOVEMBER 27, 2018 AS  
 CHAPTER 124 OF THE SARASOTA COUNTY CODE OF ORDINANCES  
 EFFECTIVE DATE JANUARY 1, 2019

## ACCEPTABLE FLOODING CRITERIA

Roadways	5-year	10-year	25-year	100-year
A. Evacuation	None	None	None	None
B. Arterials	None	None	None	6inches
C. Collectors	None	None	6inches	9inches
D. Neighborhood	None	6inches	9 inches	12inches
Parking Areas	3 inches	9inches	9 inches	12inches
Open Space: Flooding of open space is acceptable if it does not compromise public health and safety.				

## APPENDIX C15 -ATTENUATION CALCULATIONS USING THE RATIONAL METHOD EQUATION FOR THE 100-VEAR STORM

When the first inch of rainfall is retained on site, the calculation for outflow may not commence until the first inch has accumulated in the retention area. See sketch below:

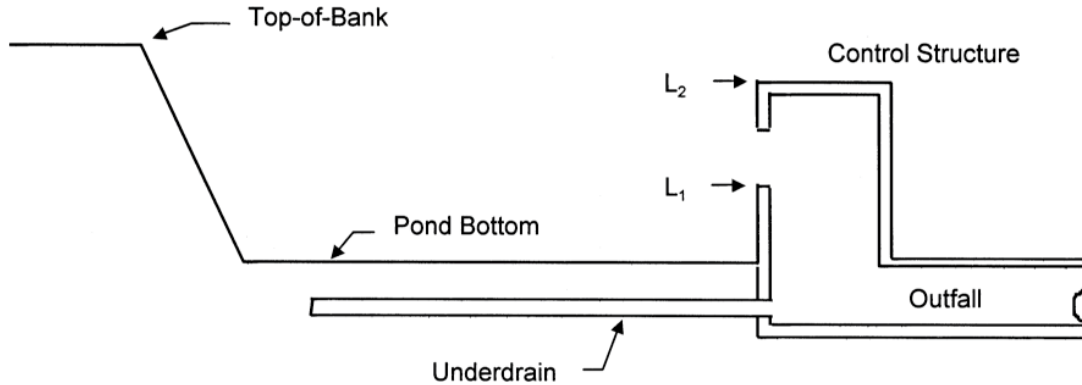

L<sub>1</sub> = level required for first inch of runoff

L<sub>2</sub> = level at which required storage volume is achieved

In the following example, if it took ten minutes for the water to reach L<sub>1</sub>, the required retention would be 14,817 ft<sup>3</sup>. [2.17 cfs x (50 min -10 min) x 60 sec/min]= 9,609 ft<sup>3</sup>.

Time, minutes	Proposed CxA	i factor	Inflow, ft <sup>3</sup>	Existing flow, cfs	Outflow, ft <sup>3</sup>	Required retention, ft <sup>3</sup>
10	0.9878	9.7	5,749	2.17	0	5,749
15	0.9878	8.5	7,557	2.17	651	6,906
20	0.9878	7.7	9,127	2.17	1,302	7,825
30	0.9878	6.5	11,557	2.17	2,604	8,953
40	0.9878	5.7	13,513	2.17	3,906	9,607
50	0.9878	5	14,817	2.17	5,208	9,609
60	0.9878	4.5	16,002	2.17	6,510	9,492
75	0.9878	<b>3.8</b>	16,891	2.17	8,463	<b>8,428</b>
90	0.9878	3.4	18,136	2.17	10,416	7,720

To compensate for the fact that 2.17 cfs does not begin to flow at time t = ten minutes, the critical volume of 9,609 ft<sup>3</sup> is increased by 20 percent. 9,609 ft<sup>3</sup> x 1.2 = 11,531 ft<sup>3</sup>. Therefore, in the example, the required storage volume below L<sub>2</sub> would be 11,531 ft<sup>3</sup>.



**APPENDIX C29 – EASEMENT MINIMUM DESIGN STANDARDS FOR PIPE SYSTEMS**

Note that the following easement width guidelines may vary by utility provider.

- A. Diameter less than 30" round or equivalent:

easement shall be 7.5 feet either side of the centerline of the pipe.

See diagram below.

- B. Diameter equal to 30" round or equivalent:

easement shall be 10 feet either side of the centerline of the pipe.

See diagram below.

- C. Diameter greater than 30" round or equivalent:

easement shall be 20 feet plus the outside diameter of the pipe in width (rounded up to the nearest 5' increment) and centered on the centerline of the pipe. See diagram below.

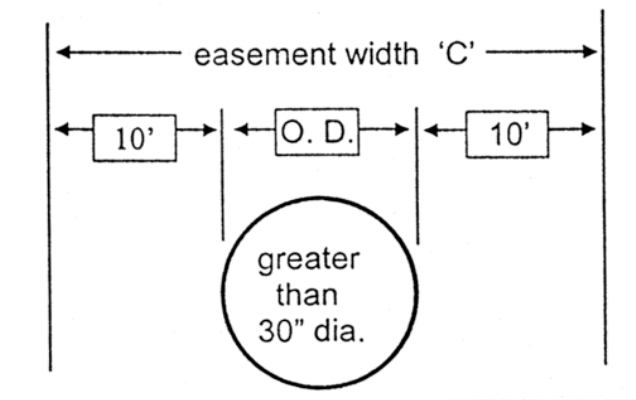
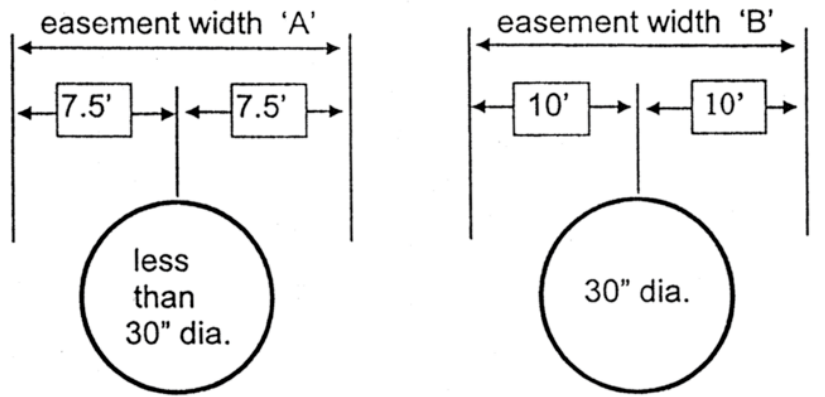

**Attachment 4**

**Cup-for-Cup Floodplain Compensation**

**Example Graphic**

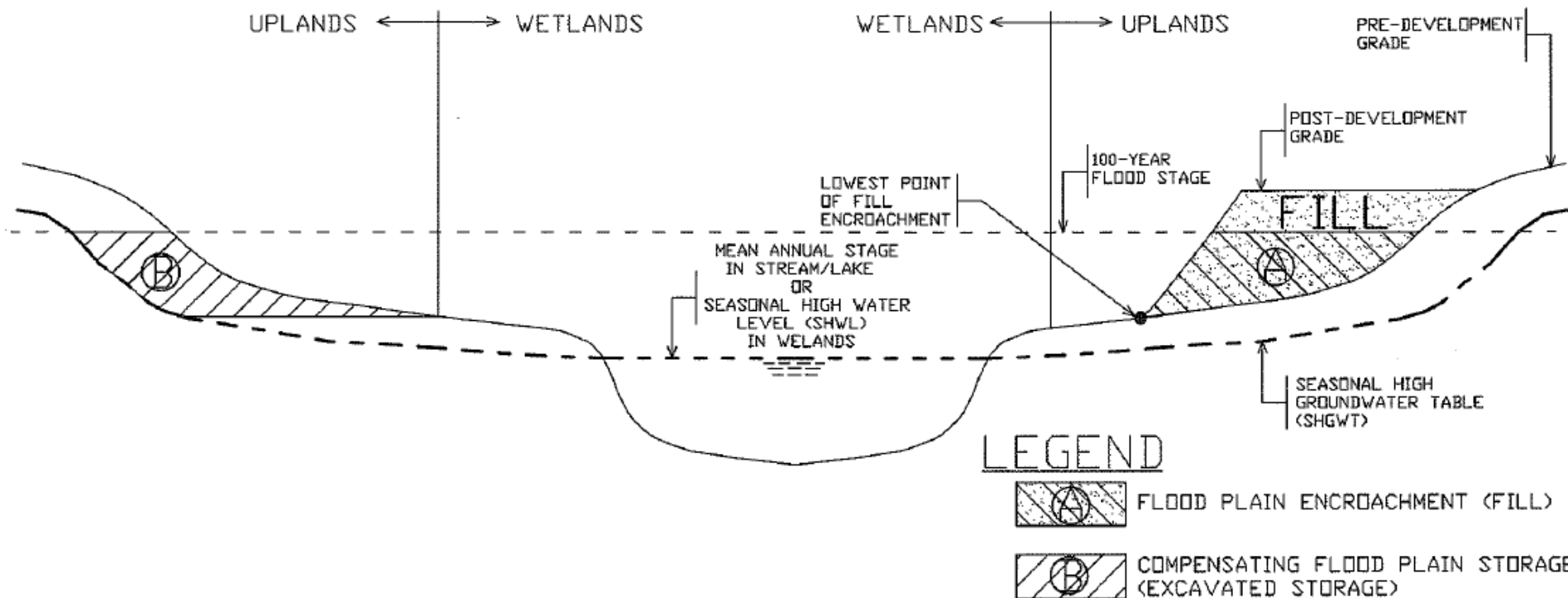

ENCROACHMENT/COMPENSATION  
IN UPLANDS  
("CUP FOR CUP")

# **Attachment 5**

## **Submittal Data Key Sheet**

Project Name:  
 Applicant:  
 Submittal Type:  
 Date:

Category	Item	Is Provided? (Yes or No)	File Name (e.g. DesignPlans.pdf, treatmentcalcs.xlsx, etc.)	Additional Info (e.g. Layer Name, Sheet, Page Number, etc.)
Checklist	Subdivision Plat and Site Development Plan Stormwater Review Checklist			
Checklist	Construction Plan Stormwater Review Checklist			
Summary Form	Construction Plan Stormwater Design Summary			
Summary Form	Construction Plan Stormwater Design Summary for Net Improvement			
Master Plan	Stormwater phasing description narrative			
Master Plan	Development phasing map including all phases			
Master Plan	Impervious area tracking spreadsheet			
Construction Plan Drawings	Project map and boundary			
Construction Plan Drawings	Stormwater management facilities and features			
Construction Plan Drawings	Design details for stormwater management system controls			
Construction Plan Drawings	Elevation information for flood storage areas, including SHWL, NWL, & DHWL			
Construction Plan Drawings	Site-specific survey			
Construction Plan Drawings	FEMA flood zone and floodway information			
Construction Plan Drawings	Floodplain encroachment and compensating storage			
Construction Plan Drawings	Structure finished floor elevations			
Construction Plan Drawings	Easements (existing and proposed)			
Construction Plan Drawings	Ditch cross-sections			
Construction Plan Drawings	Lot grading plan			
Construction Plan Drawings	Littoral zones			
Construction Plan Drawings	Wetland protection facilities			
Construction Plan Drawings	Sediment and erosion controls			
Stormwater Calculations	Narrative description of stormwater calculations and criteria			
Stormwater Calculations	Inlet level-of-service summary			
Stormwater Calculations	Pipe level-of-service summary			
Stormwater Calculations	Secondary conveyance (internal pipe) calculations			
Stormwater Calculations	Treatment volume calculations			
Stormwater Calculations	Treatment drawdown and recovery calculations			
Rational Method	Time of concentration calculations			
Rational Method	Inlet calculations			
Rational Method	Pipe calculations			
Rational Method	Pond volume calculations			
Rational Method	Pond outfall discharge calculations			
Rational Method	Floodplain compensation calculations			

Hydrograph Method	Existing conditions model
Hydrograph Method	Revised existing conditions
model Hydrograph Method	Proposed conditions model
Hydrograph Method	Summary table of model predicted peak stage
Hydrograph Method	Summary table of model predicted peak link flow
Hydrograph Method	Curve Number calculations
Hydrograph Method	Time of concentration calculations
Hydrograph Method	Modeled cross-sections
Hydrograph Method	Floodplain compensation calculations

Model Incorporated Method	Revised existing conditions model
Model Incorporated Method	Proposed conditions model
Model Incorporated Method	Summary table of model predicted peak stage
Model Incorporated Method	Summary table of model predicted peak link flow
Model Incorporated Method	Curve Number calculations
Model Incorporated Method	Time of concentration calculations
Model Incorporated Method	Modeled cross-sections

Supplemental Information	Map of existing conditions model schematic
Supplemental Information	Map of revised existing conditions model schematic
Supplemental Information	Map of proposed conditions model schematic
Supplemental Information	Map of time of concentration flow paths and basins
Supplemental Information	Map of channel flow areas for node storage calculations
Supplemental Information	Map of existing conditions floodplain
Supplemental Information	Map of revised existing condition floodplain
Supplemental Information	Map of proposed conditions floodplain
Supplemental Information	Results of ICPR4 Input Data Comparator
Supplemental Information	Results of ICPR4 Input Data QC Tool

Model Related Spatial Data	Existing Condition Basins
Model Related Spatial Data	Existing Condition Nodes
Model Related Spatial Data	Existing Condition Links
Model Related Spatial Data	Existing Condition Cross-sections
Model Related Spatial Data	Existing Condition Time of Concentration Flow Paths
Model Related Spatial Data	Existing Condition Channel Flow Area
Model Related Spatial Data	Existing Condition Floodplain
Model Related Spatial Data	Existing Condition Topographic Information Model
Related Spatial Data	Revised Existing Condition Basins
Model Related Spatial Data	Revised Existing Condition Nodes
Model Related Spatial Data	Revised Existing Condition Links
Model Related Spatial Data	Revised Existing Condition Cross-sections
Model Related Spatial Data	Revised Existing Condition Time of Concentration Flow Paths
Model Related Spatial Data	Revised Existing Condition Channel Flow Area
Model Related Spatial Data	Revised Existing Condition Floodplain
Model Related Spatial Data	Revised Existing Condition Topographic Information
Model Related Spatial Data	Proposed Condition Basins
Model Related Spatial Data	Proposed Condition Nodes

Model Related Spatial Data	Proposed Condition Links
Model Related Spatial Data	Proposed Condition Cross-sections
Model Related Spatial Data	Proposed Condition Time of Concentration Flow Paths
Model Related Spatial Data	Proposed Condition Channel Flow Area
Model Related Spatial Data	Proposed Condition Floodplain
Model Related Spatial Data	Proposed Condition Topographic Information



# **Attachment 6**

## **Time of Concentration Template**





**Attachment 7**

**FDOT Zone 6 IDF Curves and  
Development of County Regression  
Equation**

Drainage Manual  
IDF Curves

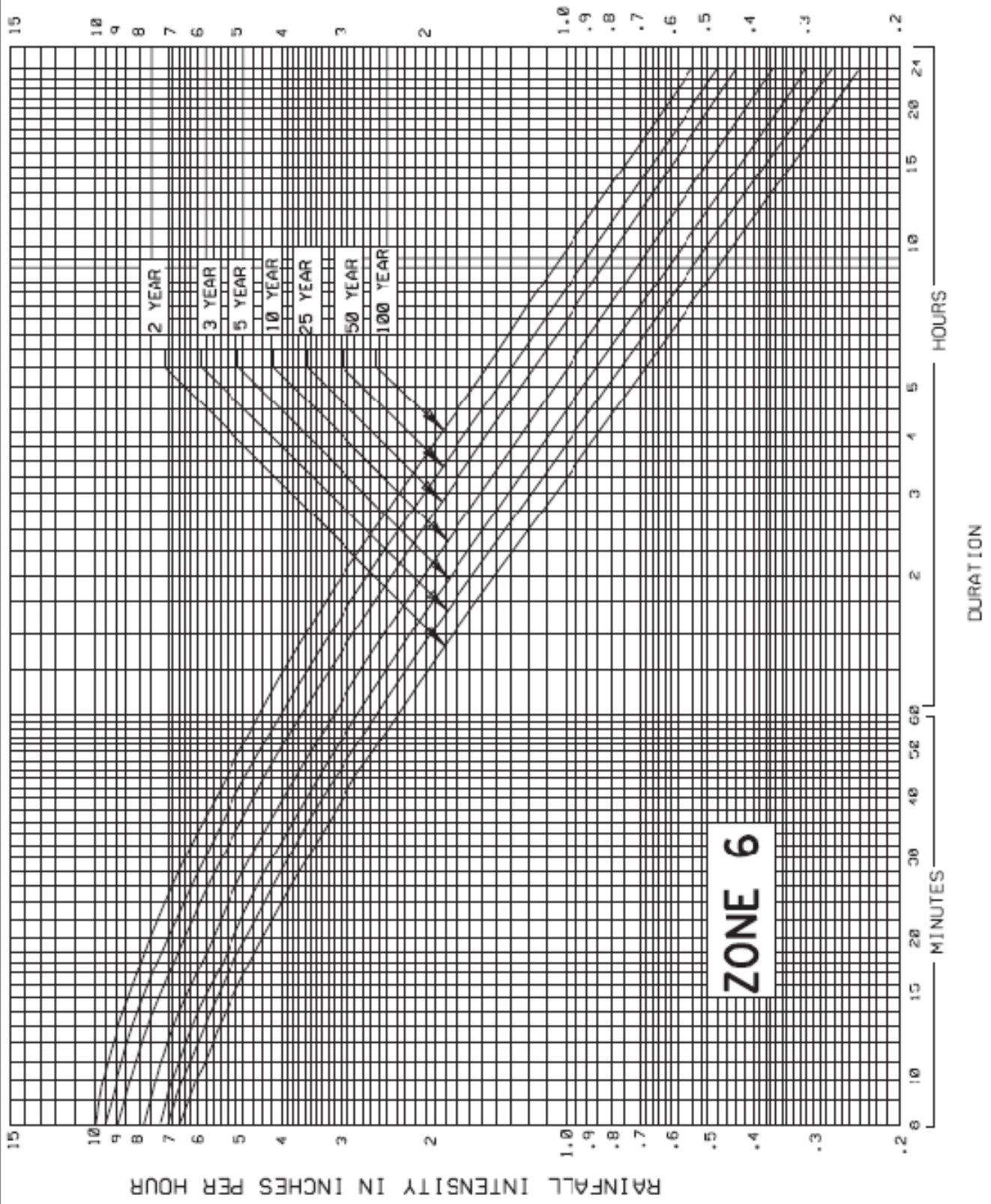

RAINFALL INTENSITY-DURATION-FREQUENCY CURVES  
ZONE 6

c	104.990		
d	17.240	R	0.999928
e	0.726	R2	0.999855 0.000145

$$I = c / (d+t)^e$$

MIN	HR	IN/HR	REG	LR	-0.11	0.03	68.45	68.56	458.75	458.05	459.48
					LSR	X	y	XY	X2	Y2	
8	0.133333	10.00	10.07		-0.07	0.01	10.00	10.07	100.7469	100	101.4995
10	0.166667	9.60	9.53		0.07	0.00	9.60	9.53	91.50812	92.16	90.86085
15	0.25	8.40	8.43		-0.03	0.00	8.40	8.43	70.84892	70.56	71.13903
20	0.333333	7.60	7.60		0.00	0.00	7.60	7.60	57.73103	57.76	57.70208
30	0.5	6.40	6.39		0.01	0.00	6.40	6.39	40.90532	40.96	40.8507
40	0.666667	5.50	5.56		-0.06	0.00	5.50	5.56	30.57888	30.25	30.91133
SO	0.833333	4.90	4.95		-0.05	0.00	4.90	4.95	24.23746	24.01	24.46708
60	1	4.50	4.47		0.03	0.00	4.50	4.47	20.1274	20.25	20.00555
120	2	3.00	2.95		0.05	0.00	3.00	2.95	8.840137	9	8.683114
180	3	2.25	2.26		-0.01	0.00	2.25	2.26	5.095243	5.0625	5.128198
240	4	1.85	1.87		-0.02	0.00	1.85	1.87	3.454735	3.4225	3.487273
300	5	1.55	1.60		-0.05	0.00	1.55	1.60	2.485838	2.4025	2.572067
600	10	0.98	0.99		-0.01	0.00	0.98	0.99	0.969405	0.9604	0.978494
900	15	0.75	0.74		0.01	0.00	0.75	0.74	0.556477	0.5625	0.550519
1200	20	0.63	0.60		0.03	0.00	0.63	0.60	0.380633	0.3969	0.365032
1440	24	0.54	0.53		0.01	0.00	0.54	0.53	0.286298	0.2916	0.281093

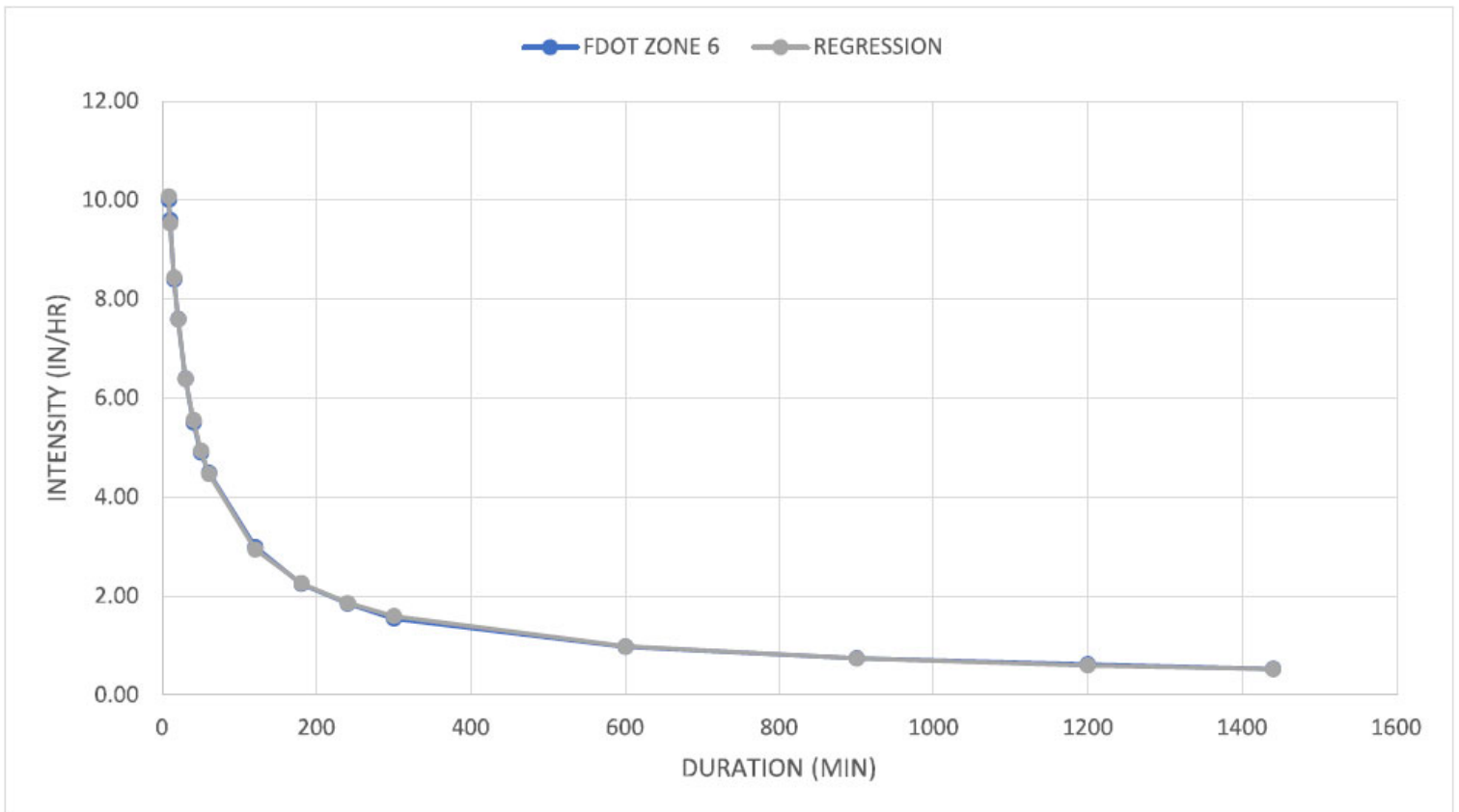

**Attachment 8**

**Example Level-of-Service Summary  
with Internal Pipe Calculations**



**Attachment 9**

**Pond Storage Volume Design Template  
for the Rational Method**

**IMPROVED MODIFIED RATIONAL METHOD (ITERATIVE)**

This spreadsheet model was developed by Jones Edmunds & Associates, Inc. for Sarasota County. The model is a tool developed to aid land development projects using the Rational Method for hydrologic design. The Engineer of Record for the land development project is responsible for ensuring all calculations are accurate and appropriate the project.

**INSTRUCTIONS**

1. Users should determine site area in acres for each development condition best represented by the runoff categories. The County has provided 5 standard categories and 1 flex category.
  2. Users should determine time of concentration in minutes for each development condition.
  3. Users should enter areas (acres) and times (minutes) under the USER INPUT section below.
  4. Only BOLD cells HIGHLIGHTED in blue may be modified in this spreadsheet.
  5. The spreadsheet will calculate by reference peak flow using the rational method and pond peak volume requirement using the modified rational method.
  6. The spreadsheet determined design pond volume is the peak volume requirement with a factor of safety increase of 20%.
- \*\*\*More discussion of the Rational Method and Modified Rational Method is provided in the County's Stormwater Manual.

**MODIFIED RATIONAL METHOD VOLUME CALCULATIONS**

c =	104.990	Vemax =	12,687 cf
d =	17.240	Vfs =	15,224 cf
e =	0.726	Design Pond Volume =	0.35 acft

Td (min)	i (in/hr)	Qi (cfs)	Vi (cf)	Vo (cf)	Ve (cf)
5	11.0	16.2	4,846	0	4,846
10	9.5	13.9	8,364	0	8,364
15	8.4	12.3	11,102	0	11,102
20	7.6	11.1	13,331	1,390	11,941
25	6.9	10.1	15,208	2,780	12,427
30	6.4	9.3	16,826	4,170	12,655
35	5.9	8.7	18,247	5,561	12,687
40	5.6	8.1	19,515	6,951	12,564
45	5.2	7.7	20,659	8,341	12,318
50	4.9	7.2	21,702	9,731	11,971
55	4.7	6.9	22,661	11,121	11,540
60	4.5	6.5	23,549	12,511	11,038
65	4.3	6.3	24,376	13,901	10,474
70	4.1	6.0	25,150	15,292	9,858
75	3.9	5.8	25,878	16,682	9,196
80	3.8	5.5	26,565	18,072	8,493
85	3.6	5.3	27,216	19,462	7,754
90	3.5	5.2	27,836	20,852	6,983
95	3.4	5.0	28,426	22,242	6,184
100	3.3	4.8	28,990	23,632	5,358
105	3.2	4.7	29,530	25,023	4,508
110	3.1	4.6	30,049	26,413	3,636
115	3.0	4.4	30,548	27,803	2,745
120	2.9	4.3	31,029	29,193	1,836
125	2.9	4.2	31,493	30,583	910
130	2.8	4.1	31,941	31,973	-32
135	2.7	4.0	32,375	33,363	-988
140	2.7	3.9	32,796	34,754	-1,958
145	2.6	3.8	33,204	36,144	-2,940
150	2.6	3.7	33,600	37,534	-3,934
155	2.5	3.7	33,986	38,924	-4,938
160	2.4	3.6	34,361	40,314	-5,954
165	2.4	3.5	34,726	41,704	-6,978
170	2.4	3.4	35,082	43,094	-8,012
175	2.3	3.4	35,429	44,485	-9,055
180	2.3	3.3	35,769	45,875	-10,106
185	2.2	3.3	36,100	47,265	-11,165
190	2.2	3.2	36,424	48,655	-12,231
195	2.1	3.1	36,741	50,045	-13,304
200	2.1	3.1	37,052	51,435	-14,384
205	2.1	3.0	37,356	52,825	-15,470
210	2.0	3.0	37,654	54,216	-16,562
215	2.0	2.9	37,946	55,606	-17,660
220	2.0	2.9	38,232	56,996	-18,763
225	2.0	2.9	38,514	58,386	-19,872
230	1.9	2.8	38,790	59,776	-20,986
235	1.9	2.8	39,061	61,166	-22,105
240	1.9	2.7	39,328	62,556	-23,228

**USER INPUTS**

	Rational C	Post-Development Area	Pre-Development Area
Water Features	1.00	<b>0.35</b>	<b>0.00</b>
Heavily Improved or Impervious	0.95	<b>1.00</b>	<b>0.50</b>
Moderately Improved	0.75	<b>0.15</b>	<b>0.00</b>
Lightly Improved	0.55	<b>0.00</b>	<b>0.00</b>
Sandy Pervious	0.20	<b>0.25</b>	<b>1.25</b>
Other Areas	<b>99.00</b>	<b>0.00</b>	<b>0.00</b>
<b>Total Area</b>		<b>1.75</b>	<b>1.75</b>
<b>Rational C Value</b>		<b>0.84</b>	<b>0.41</b>
<b>Time of Concentration</b>		<b>15</b>	<b>30</b>

**RATIONAL METHOD PEAK FLOW CALCULATIONS**

	Post-Development	Pre-Development	
Q	12.34	4.63	cfs
C	0.84	0.41	*
i	8.4	6.4	in/hr
A	1.75	1.75	acre
C X A	1.463	0.725	*



**Attachment 10**

**2005 Sarasota County Watersheds  
Floodplain Model Methodology Report**

■  
*Sarasota County Watersheds*

# Floodplain Model Methodology

© Kimley-Horn and Associates, Inc. 2005



Kimley-Horn  
and Associates, Inc.

## 1.0 FLOODPLAIN ANALYSIS METHODOLOGY

### 1.0.1 HYDROLOGY

The Natural Resources Conservation Service (NRCS), formerly known as the Soil Conservation Service (SCS) Curve Number and Unit Hydrograph Method contained within ICPR version 2.11 was used for the hydrologic portion of the modeling. The SCS unit hydrograph method requires certain information be provided to generate runoff hydrographs. This information typically includes (1) subbasin area, (2) rainfall, (3) runoff curve number, (4) time of concentration, and (5) peak rate factor.

Subbasin areas and rainfall information are measurable quantities are typically not subject to judgement. The runoff curve number is a parameter that determines the volume of runoff. It is typically an indicator of impervious coverage and/or water table depth. Therefore for a given land use and/or initial water table depth under design conditions, careful thought should minimize the subjectivity of selecting this parameter. Finally, the time of concentration and peak rate factor are unit hydrograph parameters. They dictate the magnitude and shape of the runoff hydrograph. Selection of these parameters has been extremely subjective to engineering judgement. In recent years there has been significant discussion on peak rate factors in Southwest Florida which has led to several conclusions that peak rate factors in the southern portion of Florida should be around 100, particularly for undeveloped or rural watersheds. Time of concentration parameters remain extremely subjective and are typically computed using empirical equations provided by numerous literature sources.

The procedures to be used for the Sarasota County watershed models are discussed below.

#### SUBBASIN AREA

Topographic maps and construction plans for the entire watershed were used to delineate subbasins. Subbasins were delineated in concert with the hydraulic network.

#### RAINFALL

This information is typically available as an actual storm event that has been measured or a design event that is recommended by an authoritative source. Design storms were simulated using rainfall volumes, distributions, and durations recommended by the Southwest Florida Water Management District (24-hour duration).

#### SELECTION OF DESIGN CURVE NUMBER

The runoff volume for each subbasin was computed as prescribed by the NRCS Runoff Curve Method with the exception that the area of directly connected impervious coverage was first determined and subtracted from the total area. This directly connected impervious area is that which is connected to the subbasin outfall by impervious surfaces such that no infiltration can take place.

The remaining area in the subbasin is comprised of non-directly connected impervious areas (impervious surfaces where runoff can flow over pervious surface before reaching the subbasin outfall) and pervious areas. A weighted Runoff Curve Number was computed for this remaining portion of each subbasin. Runoff Curve Numbers for non-directly connected impervious areas was taken as 98. Runoff Curve Numbers for pervious areas was taken as

78, for design conditions. Several references were consulted to support a design Runoff Curve Number of 78 for pervious surfaces and are discussed briefly below:

1. Sarasota County - Development Services

Sarasota County Development Services administers stormwater related ordinances and has typically required a Runoff Curve Number of 70 for undeveloped areas in determining allowable release rates from new development.

2. Southwest Florida Water Management District- Basis of Review Permit Manual

The Southwest Florida Water Management District (SWFWMD) guidelines recommend the use of the NRCS Method under antecedent moisture condition II (average) when determining design peak discharge rates. This would basically default to the method discussed below.

3. NRCS (fka SCS) -Technical Release No. 55 (2<sup>nd</sup> Edition)

The NRCS provides national guidelines for selecting Runoff Curve Numbers by hydrologic soil group. For open space, grassland, or pasture, the following Runoff Curve Numbers are presented:

**Table 1.0.1.1 - NRCS Curve Numbers for Open Space**

Open Space, Condition	Soil Group A	Soil Group B	Soil Group C	Soil GroupD
Poor Condition	68	79	86	89
Fair Condition	49	69	79	84
Good Condition	39	61	74	80

Most soils in Sarasota County are considered hydrologic soil group *BID*. Assuming open space in fair condition and a hydrologic soil group C as indicative of average wet season conditions yields a design Runoff Curve Number of 79.

4. Camp Dresser & McKee (CDM) - Sarasota County Stormwater Master Plan

In 1986, CDM prepared a Stormwater Master Plan for Sarasota County. This Plan included detailed hydrologic analyses for the Phillippi Creek and Alligator Creek basins using the Runoff Block from the SWMM computer model, as customized by CDM. To account for infiltration losses, CDM utilized Horton's equation. Unique to the CDM model, a maximum amount of soil storage is specified in the Runoff Block input file. The maximum amount of soil storage was determined by CDM for each NRCS Soil Group, as follows:

**Table 1.0.1.2 - Maximum Infiltration as a Function of Hydrologic Soils Group, COM (1986)**

Soil Group	Maximum fufiltration
A	3.8"
B	3.0"
C	2.2"
D	1.6"

Consistent with their Runoff Block input file, CDM indicates that for design purposes, an NRCS Soil Classification C was appropriate. In addition, 0.1" of depression storage was specified in the Runoff Block input file for the majority of subbasins in Phillippi Creek. These rainfall loss assumptions equate to a Runoff Curve Number of 81.

5. South Florida Water Management District- Basis of Review Permit Manual

With the understanding that hydrologic conditions in Sarasota County may be more indicative of those found within the limits of the South Florida Water Management District (SFWMD) than those in the Southwest Florida Water Management District, the formers' guidelines for determining runoff from pervious surfaces were consulted. These guidelines recommend using antecedent moisture conditions based upon average, wet-season water table elevations for design purposes. The SFWMD Permit Manual provides soil storage capacity for normal sandy soils found within the District in their natural state, as estimated by the NRCS. Specifically, Curve Numbers are a function of soil storage, which is a function of the depth to the water table as indicated below:

**Table 1.0.1.3-Available Storage as a Function of Depth to Water Table (NRCS), and Corresponding Runoff Curve Number**

Depth to Water Table	Available Storage	Runoff Curve Number
1'	0.6"	94
2'	2.5"	80
3'	6.6"	60
4'	10.9"	48

For design purposes, an assumed wet-season depth to water table of 2' to 2.5' yields a design Runoff Curve Number between 70 and 80.

6. University of Florida-Estimation of Runoff Peak Rates and Volumes from Flatwoods Watersheds

Supported by the South Florida Water Management District, this report included as an objective re-examining runoff volume estimating techniques using actual data collected by the South Florida Water Management District and the U.S. Geological Survey on five agricultural (improved and unimproved pasture) watersheds ranging from 20 to 3600 acres. The data base considered approximately 160 storms, all equal to or exceeding 0.70 inches and having reliable, concurrent runoff and water table data.

Of the seven different runoff estimating techniques considered, those that incorporated the antecedent water table conditions were found to provide the best results. The Agricultural Research Service (ARS) method was reported to consistently perform best on all event classes. The ARS method relates available soil storage to the depth to the water table. The relationship given by the ARS method between depth to water table, available soil storage, and Runoff Curve Number is summarized below:

**Table 1.0.1.4 -Available Storage as a Function of Depth to Water Table (ARS), and Corresponding Runoff Curve Number**

Depth to Water Table	Available Soil Storage	Runoff Curve Number
0.5'	0.25"	97.5
1.0'	0.81"	92.5
1.5'	1.44"	87
2.0'	2.19"	82
2.5'	2.94"	77
3.0'	3.69"	73
3.5'	4.44"	69
4.0'	5.19"	66

An average wet-season depth to water table between 2' and 2.5' would correspond to a design Runoff Curve Number between 77 and 82.

7. U.S. Geological Survey-Hydrological Data Collection in Sarasota County

The U.S. Geological Survey, through a cooperative funding agreement with Sarasota County gauged seven watersheds within Sarasota County between mid 1991 and mid 1993. Significant rainfall and runoff were recorded in the last 2 years of this period of record to the extent that the U.S.G.S. was able to develop stage discharge rating curves at all seven gauge locations. A digital copy of the incremental rainfall and runoff measurements was obtained from the U.S.G.S. Areas upstream of the gauge sites were also verified independently using SWFWMD 1-foot contour aerials, as opposed to USGS 5-foot contour aerials. Runoff curve numbers were independently calculated using the NRCS runoff equation:

$$Q = \frac{(P - I_a)^2}{(P - I_a) + S}$$

where

- Q = runoff (in),
- P = rainfall (in),
- S = potential maximum retention after runoff begins (in), and
- I<sub>a</sub> = initial abstraction (in).

If I<sub>a</sub> is approximated as 0.2S, then the runoff equation reduces to:

$$Q = \frac{(P - 0.2S)^2}{(P + 0.8S)}$$

The above form of the runoff equation can be used to solve for S, since Q and P are known. Curve number is related to S by the equation:

$$CN = \frac{1000}{S + 10}$$

The results of the reductions for the four rural and/or agricultural basins are provided in the following table:

**Table 1.0.1.5 - Computed Wet Season Runoff Curve Numbers in Sarasota County**

<b>South Creek</b>			
Date	Rainfall (inches)	Runoff (inches)	Curve Number
6/23/92	17.20"	4.30"	29.7
9/06/92	1.17"	0.13"	79.4
9/13/92	1.83"	0.39"	77.9
3/13/93	2.93"	0.69"	70.3
4/01/93	3.30"	1.27"	76.8
AverageCN			66.8
Average Wet Season CN			78.6
<b>Forked Creek</b>			
Date	Rainfall (inches)	Runoff (inches)	Curve Number
6/23/92	12.83"	7.00"	58.2
8/09/92	6.20"	1.94"	58.7
10/02/92	1.29"	0.45"	88.4
3/13/93	1.25"	0.07"	73.9
4/15/93	1.06"	0.08"	78.4
AverageCN			71.5
Average Wet Season CN			73.5
<b>Gottfried Creek</b>			
Date	Rainfall (inches)	Runoff (inches)	Curve Number
6/24/92	15.15"	8.41"	55.0
8/09/92	3.55"	1.09"	70.9
8/11/92	1.21"	0.37"	87.7
10/02/92	2.13"	0.74"	82.1
1/08/93	2.33"	0.13"	60.2
3/13/93	1.80"	0.09"	65.1
3/17/93	1.06"	0.07"	77.5
4/01/93	1.24"	0.09"	75.3
4/15/93	1.62"	0.10"	69.3
5/08/93	1.27"	0.06"	72.0
AverageCN			71.5
Average Wet Season CN			80.2
<b>Ainper Creek</b>			
Date	Rainfall (inches)	Runoff (inches)	Curve Number
6/23/92	16.11"	6.24"	40.5
9/25/92	1.33"	0.83"	94.6
10/02/92	2.31"	1.21"	87.8
10/11/92	1.20"	0.43"	89.3
7/14/93	1.70"	0.05"	63.4
AverageCN			75.1
Average Wet Season CN			83.8

Based upon the independent reduction of the USGS data, average runoff curve numbers in the four rural basins in Sarasota County range between 66.8 and 75.1. When considering the wet season (between June and October), the average runoff curve numbers range between 73.5 and 83.8. It should be noted that the largest storm recorded in late June of 1992 was not considered in the average wet season computation due to the fact that the antecedent moisture conditions preceding this event were extremely dry. In addition, rural areas typically do not produce runoff at the initiation of the wet season, as it can take several weeks to a month for groundwater and wetland water levels to be replenished following April and May.

### PEAK RATE FACTOR DETERMINATION

The National Resources Conservation Service (NRCS) hydrologic method utilizes a site specific unit hydrograph and a storm specific excess rainfall hyetograph to generate a storm specific runoff hydrograph. While the antecedent moisture conditions and rainfall distribution and volume vary from event to event, the dimensionless unit hydrograph is assumed to remain constant for a given subbasin.

The dimensionless unit hydrograph is defined by the watershed area and time of concentration, as well as a peak rate factor (PRF). Although a standard peak rate factor of 484 is recommended by the NRCS, peak rate factors have been found to deviate as a function of local topography. National Engineering Handbook No. 4 indicates that a value of 300 may be appropriate for 'flat swampy' areas, and a value of 284 has been developed for the Delaware/Maryland/Virginia (Delmarva) coastal area based upon analysis of seven (7) total storm events and four (4) watersheds with slopes between 2% and 5%. Subsequent research by the University of Florida on five (5) watersheds and approximately 80 storm events has indicated peak rate factors as low as 75 may be appropriate in southern Florida. Peak rate factors commonly used for design purposes in the Southwest Florida Water Management District include 256, 284 and 323.

The accurate estimation of peak rate factors for the southern portion of Florida, which includes Sarasota County, has received much attention in recent years. Standard de-convolution is one technique which is prescribed for determining unit hydrographs from observed data and requires both rainfall and runoff measurements. However, this technique is very tedious and since it is extremely sensitive to the rainfall distribution, it is frequently not successful.

#### 1. Description of Study Areas

The five study areas are situated in Sarasota County, Florida. These study areas are nearly level and contain various degrees of both urbanization and stormwater management facilities. A brief overview of each of the study areas is provided below:

Walker Creek The Walker Creek study area contains approximately 2,939 acres and is located in the northwest portion of Sarasota County. This coastal basin generally drains from east to west to Whitaker Bayou and Sarasota Bay. It is essentially 100% developed with mixed urban land uses. Although it contains a well-defined network of drainage ditches, minimal stormwater management facilities are located in the study area. Underlying soils consist primarily of poorly drained Eauggallie and Myakka Fine Sand.

Clower Creek The Clower Creek study area contains a reported 227 acres and is located in west central Sarasota County. Land uses in this developed coastal basin include a regional



mall, strip shopping centers, a mobile home park, residential areas, and major roadway corridors. An estimated 70% of this basin is serviced by stormwater management facilities. However many of these systems have been in existence for 20 years or more and may therefore not meet current flood control design standards. This small coastal basin ultimately empties into Little Sarasota Bay. Drainage is primarily from east to west and is serviced by a man-made ditch, a significant portion of which has been enclosed by a large, storm sewer system. Primary underlying soils include poorly drained Eaugallie and Myakk:a Fine Sand and Pineda Fine Sand.

Catfish Creek The Catfish Creek study area contains an estimated 3,180 acres and is located in the west central portion of Sarasota County. This coastal basin generally drains north to south and eventually empties into Little Sarasota Bay. At the time of the data collection, this basin was approximately 70% developed, primarily with residential land uses, although some industrial type land uses are located within its headwaters. With the exception of these older industrial areas, the developed portions of this study area are serviced by state of the art stormwater management facilities. A well-defined canal, known as the Catfish Creek Main and three lateral ditches provide drainage for the study area. Primarily soils are poorly drained Eaugallie and Myakk:a Fine Sand and Pineda Fine Sand.

South Creek The South Creek study area contains 294 acres located at the headwaters of the 20 square mile South Creek watershed. This study area is located in central Sarasota County and eventually discharges into Drymond Bay. Although the land use characteristics of this study area are primarily rural in nature, an on-going institutional development associated with a medical complex is located in its upper portion. Drainage is serviced by a man-made ditch, which conducts stormwater from north to south along the westerly boundary of the study area. Canals with large water control structures provide drainage for the institutional area. Primary soils are poorly drained Eaugallie and Myakk:a Fine Sand and Ona Fine Sand.

Gottfried Creek The Gottfried Creek study area contains an estimated 1,065 acres and is located in southwest Sarasota County. This coastal basin ultimately discharges into Lemon Bay. Although a large portion of this study area is undeveloped ( $\pm 60\%$ ), some residential development with minimal stormwater management facilities are scattered throughout. Drainage in this study area is serviced by a man-made ditch, which was excavated through the center of an elongated wetland slough. Stormwater is conveyed northwest and then northeast through this study area. Primary soils include poorly drained Eaugallie and Myakk:a Fine Sand.

## 2. Data Collection and Analysis

Continuous rainfall and water level recorders for all study areas except the South Creek study area were placed and operated by the U.S.G.S., in cooperation with Sarasota County between October of 1991 and 1993. The South Creek study area is gauged with continuous rainfall and water level recorders, which have been in place since late 1992 and are operated by the Palmer Ranch.

Although the initial monitoring period between October 1991 and June 1992 produced few rainfall/runoff events, approximately 15 to 18 inches of rainfall fell in a three day period resulting in extensive and severe flooding throughout much of Sarasota County in late June of 1992. The 1992 summer rainy season, as well as those in 1993 and 1994 produced many rainfall events exceeding 1 inch and runoff events exceeding  $\frac{1}{2}$  inch which allowed numerous discharge measurements and the development of reliable rating curves at all monitoring sites.

Continuous rainfall and discharge measurements were obtained from the U.S.G.S. for all sites except South Creek. Continuous rainfall and water level strip charts for the South Creek site were obtained from the Palmer Ranch. Discharge measurements and rating curve information for the South Creek site were developed by CCI Environmental Services, Incorporated.

This information was reviewed and reduced for each of the study areas. Specifically, rainfall hyetographs and distributions, as well as direct runoff hydrographs were ascertained from the data. Although base flow appeared to be negligible for these small coastal study areas, it was determined that the runoff hydrographs consist of both water released by the surficial water table as well as surface runoff. Although the surficial groundwater component may be significant, no inherent separation method was obvious. Direct runoff hydrographs (DRH) were determined using the straight-line approach. Initial rainfall and runoff times were noted to determine the time of the runoff hydrograph peaks. Rainfall/runoff events which were reduced are summarized in Table 2.2.1.6 and include 17 events for Walker Creek, 14 events for Catfish Creek, 9 events for Clower Creek, 5 events for South Creek, and 12 events for Gottfried Creek.

**Table 1.0.1.6 - Summary of Rainfall/Runoff Events**

	<b>Walker</b>	<b>Creek</b>	
Date	Rainfall	Runoff	Peak Discharge
06/24/92	5.31"	1.24"	399 cfs
07/23/92	2.56"	1.25"	427 cfs
08/07/92	1.79"	1.05"	388 cfs
08/11/92	0.98"	0.48"	149 cfs
09/04/92	2.39"	0.09"	328 cfs
09/05/92	2.03"	0.59"	246 cfs
09/26/92	1.46"	0.97"	270 cfs
02/26/93	1.18"	0.23"	98 cfs
03/12/93	1.26"	0.43"	122 cfs
04/01/93	3.05"	1.20"	316 cfs
04/05/93	1.08"	0.37"	128 cfs
04/15/93	1.65"	0.40"	113 cfs
05/30/93	1.42"	0.12"	85 cfs
05/31/93	0.74"	0.06"	40 cfs
07/01/93	2.54"	0.49"	236 cfs
07/07/93	0.73"	0.14"	36 cfs
07/14/93	0.92"	0.10"	47 cfs
	<b>Clower</b>	<b>Creek</b>	
Date	Rainfall	Runoff	Peak Discharge
03/30/92	0.86"	0.38"	21 cfs
07/12/92	1.53"	0.86"	36 cfs
07/22/92	1.28"	0.89"	43 cfs
08/14/92	0.79"	0.11"	19 cfs
09/02/92	1.67"	1.09"	64 cfs
09/04/92	1.15"	0.61"	38 cfs

09/13/92	3.10"	2.49"	108 cfs
01/14/93	1.80"	0.89"	41 cfs
01/15/93	1.28"	0.63"	35 cfs
	<b>Catfish</b>	<b>Creek</b>	
Date	Rainfall	Runoff	Peak Discharge
01/08/93	1.68"	0.05"	11 cfs
01/14/93	3.25"	0.69"	68 cfs
01/25/93	1.48"	0.43"	41 cfs
02/22/93	0.08"	0.06"	9 cfs
02/26/93	1.02"	0.18"	29 cfs
03/03/93	0.52"	0.06"	6 cfs
03/13/93	2.54"	0.64"	133 cfs
04/01/93	4.49"	2.06"	301 cfs
04/05/93	1.25"	0.31"	61 cfs
04/15/93	1.73"	0.49"	83 cfs
07/31/93	0.76"	0.06"	21 cfs
08/16/93	1.13"	0.15"	31 cfs
08/30/93	1.60"	0.34"	44 cfs
09/13/93	0.88"	0.49"	62 cfs
	<b>South</b>	<b>Creek</b>	
Date	Rainfall	Runoff	Peak Discharge
03/12/93	2.70"	1.40"	7 cfs
04/01/93	4.70"	3.33"	19.cfs
04/15/93	1.70"	1.22"	7 cfs
03/01/94	2.70"	0.74"	5 cfs
10/13/94	1.80"	1.34"	9 cfs
	<b>Gottfried</b>	<b>Creek</b>	
Date	Rainfall	Runoff	Peak Discharge
06/24/92	15.15"	8.41"	118 cfs
08/09/92	3.55"	1.09"	20 cfs
08/11/92	1.21"	0.37"	15 cfs
10/02/92	2.13"	0.74"	17 cfs
01/08/93	2.33"	0.13"	2 cfs
03/13/93	1.80"	0.09"	4 cfs
03/17/93	1.06"	0.07"	2 cfs
04/01/93	1.24"	0.09"	2 cfs
04/15/93	1.62"	0.10"	3 cfs
08/31/93	not avail.	0.07"	5 cfs
09/15/93	not avail.	0.08"	4 cfs
10/02/91	not avail.	0.63"	22 cfs

In addition, some general trends were noted from the review of the observed data:

- All basins appear to respond relatively quickly to the initiation of rainfall.
- Runoff hydrographs for all basins appear to have relatively long recession limbs. ( A significant portion of the runoff volume is contained in the recession limb of the hydrograph.)
- All basins responded only to rainfall and contained no discernable base flow.
- Although a significant portion of the runoff hydrograph volume is attributable to surficial groundwater, it was not possible to dissect it from the surface water component.
- The time to the peak runoff discharge appears inversely related to the degree of urbanization and drainage. Accordingly, the urban study areas produced more discrete runoff events than the rural study areas.
- A possible linear relationship between runoff volumes and peak discharges seemed generally apparent for all study areas.

### 3. NRCS Unit Hydrograph

The NRCS unit hydrograph method (1985) has been developed and extensively used and is based upon the following equation:

$$qp = \frac{KAQ}{Tp} \quad (1)$$

where, qp = peak discharge, in cfs; K = peak rate factor; A = drainage area, in square miles; Q = runoff volume, in inches; Tp = time to peak, in hours.

Unit hydrographs are computed by the NRCS computer model through specification of a peak rate factor, drainage area, and time of concentration. By definition, the runoff volume for the NRCS unit hydrograph is equal to 1 inch. A user specified rainfall distribution is then used to compute the resulting runoff hydrograph through standard convolution techniques.

Conversely, if continuous rainfall and discharge measurements are available, event specific unit hydrographs may be determined through de-convolution techniques. However, this de-convolution procedure is tedious and its success is very dependent upon the uniformity of the rainfall distribution. Although this de-convolution was employed, it had limited success and yielded very event specific unit hydrographs.

An alternative procedure was utilized to develop generic unit hydrographs for each of the study areas based upon the previously observed trend that a linear relationship between runoff volume and peak discharges may exist. As such, peak discharge rates were plotted against runoff volumes for each study area. A linear regression analysis was performed for each study area, which allowed the determination of the peak discharge rate corresponding to one inch of runoff. Standard errors were added to provide a bias toward single, high intensity events. From this analysis, K/Tp ratios were computed using equation 1. The results of the linear regression analyses are presented in TABLE 2.2.1.7.

**Table 1.0.1.7 - Results of Peak Discharge vs. Runoff Volume Linear Regression Analysis**

Location	Area	Constant	Std. Error	r2	No.of Obs.	X Coeff.	Std. Error	qp R = 1"	K/Tp	qp/Area
<b>Walker</b>	2,939 acres	<b>23.32</b>	37.55	<b>0.93</b>	<b>17</b>	<b>302.55</b>	<b>22.10</b>	385.5 cfs	<b>83.9</b>	<b>0.13</b>
Clower	227 acres	<b>10.27</b>	6.08	0.96	9	<b>143.39</b>	<b>3.19</b>	59.9 cfs	<b>166.0</b>	<b>0.26</b>
Catfish	3,180 acres	<b>2.81</b>	17.6	0.95	<b>14</b>	<b>39.32</b>	<b>9.41</b>	173.2 cfs	<b>34.9</b>	0.05
South	292 acres	0.95	0.99	<b>0.97</b>	5	<b>5.27</b>	0.50	7.7 cfs	<b>16.8</b>	<b>0.03</b>
Gottfried	1,065 acres	<b>4.41</b>	4.18	0.98	<b>12</b>	13.63	<b>0.53</b>	22.8 cfs	<b>13.7</b>	<b>0.02</b>

The constant K/Tp ratios for each basin enabled the development of Tp estimates for a range of peak rate factors. The following five (5) peak rate factors were considered.

<u>PEAK RATE FACTOR</u>	<u>SOURCE</u>
75	University of Florida
256	Commonly used in Florida
284	Delmarva Unit Hydrograph
323	Commonly used in Florida
484	Standard NRCS Unit Hydrograph

Each combination of K and Tp were simulated for each storm and for each study area. Dimensionless coordinates available from others (1989) were used to define unit hydrographs with shape factors of 256, 323, and 484. Curvilinear dimensionless unit hydrographs with peak rate factors of 75 (1986) and 284 were prepared using the procedures outlined in the Neidrauer paper (Undated). Storm specific runoff curve numbers were computed using rainfall and runoff volumes for each event. For estimation purposes, the basin lag time was assumed approximately equal to the unit hydrograph time to peak. Therefore, the time of concentration was estimated by the following NRCS equation:

$$T_c = \text{Lag}(\sim T_p)/0.6 \quad (2)$$

#### 4. Results and Conclusions

Tables 2.2.1.8 through 2.2.1.12 on the following pages compare observed and computed peak discharges and their associated times for the NRCS unit hydrograph analyses. These comparisons indicate that all combinations of peak rate factors and times of concentration simulate the observed flows with reasonable accuracy for all storms and for all watersheds. However, the combination of the lowest peak rate factor and time of concentration consistently performed the best in simulating the observed time to peak of the hydrograph for all watersheds.

- All K/Tp ratios resulted in runoff hydrograph peak discharges which are consistent and in reasonably good agreement with those measured.
- Overall, runoff hydrographs computed using Tp's associated with a K of 75 provided the closest agreement between observed and simulated runoff hydrograph times to peak.

Table 1.0.1.8a - Comparison of Observed and Computed Peak Discharges -Walker Creek

Storm	Obs. Flow	Series 1 K=75 Tc=89 min	Series 2 K=256 Tc=305 min	Series 3 K=284 Tc=338 min	Series 4 K=323 Tc=385 min	Series 5 K=484 Tc=577min
06/24/92	399 cfs	325 cfs	309 cfs	349 cfs	319 cfs	355 cfs
07/23/92	427 cfs	422 cfs	424 cfs	429 cfs	429 cfs	430 cfs
08/07/92	388 cfs	350 cfs	353 cfs	358 cfs	357 cfs	360 cfs
08/11/92	149 cfs	164 cfs	163 cfs	164 cfs	165 cfs	165 cfs
09/04/92	328 cfs	298 cfs	304 cfs	307 cfs	309 cfs	309 cfs
09/05/92	246 cfs	192 cfs	201 cfs	204 cfs	204 cfs	205 cfs
09/26/92	270 cfs	329 cfs	332 cfs	334 cfs	334 cfs	335 cfs
02/96/93	98 cfs	79 cfs	80 cfs	82 cfs	82 cfs	82 cfs
03/12/93	122 cfs	137 cfs	138 cfs	143 cfs	142 cfs	145 cfs
04/01/93	316 cfs	332 cfs	310 cfs	357 cfs	320 cfs	363 cfs
04/05/93	128 cfs	123 cfs	124 cfs	126 cfs	125 cfs	126 cfs
04/15/93	113 cfs	125 cfs	126 cfs	134 cfs	130 cfs	135 cfs
05/30/93	85 cfs	40 cfs	40 cfs	40 cfs	40 cfs	40 cfs
05/31/93	40 cfs	21 cfs	22 cfs	22 cfs	22 cfs	22 cfs
07/01/93	236 cfs	164 cfs	164 cfs	167 cfs	166 cfs	167 cfs
07/07/93	36 cfs	49 cfs	50 cfs	50 cfs	50 cfs	50 cfs
07/14/93	47 cfs	31 cfs	32 cfs	33 cfs	33 cfs	33 cfs

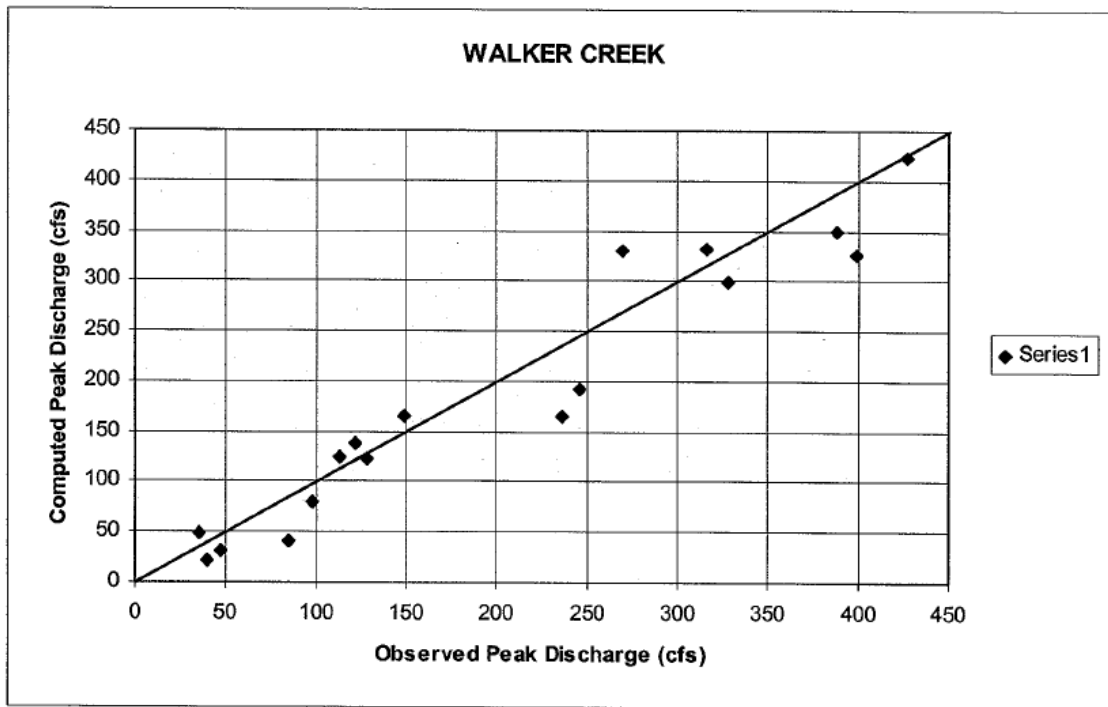

Table 1.0.1.8b - Comparison of Observed and Computed Peak Discharge Times -Walker Creek

Storm	Obs. TP	Series 1 K=75 Tc=89 min	Series 2 K=256 Tc=305 min	Series 3 K=284 Tc=338 min	Series 4 K=323 Tc=385 min	Series 5 K=484 Tc=577 min
06/24/92	7.75 hrs	12.26 hrs	14.00 hrs	13.75 hrs	14.50 hrs	16.00 hrs
07/23/92	1.50 hrs	1.78 hrs	4.00 hrs	4.25 hrs	4.75 hrs	6.75 hrs
08/07/92	2.00 hrs	1.58 hrs	4.00 hrs	4.25 hrs	5.00 hrs	7.00 hrs
08/11/92	1.25 hrs	1.19 hrs	3.50 hrs	3.75 hrs	4.50 hrs	6.50 hrs
09/04/92	1.50 hrs	1.78 hrs	4.25 hrs	4.50 hrs	5.00 hrs	7.00 hrs
09/05/92	1.25 hrs	1.78 hrs	4.25 hrs	4.25 hrs	5.00 hrs	7.00 hrs
09/26/92	3.00 hrs	2.77 hrs	5.00 hrs	5.50 hrs	6.00 hrs	8.00 hrs
02/26/93	2.50 hrs	3.56 hrs	5.75 hrs	5.75 hrs	6.50 hrs	8.50 hrs
03/12/93	5.75 hrs	3.16 hrs	5.00 hrs	5.25 hrs	5.75 hrs	7.75 hrs
04/01/93	2.50 hrs	5.54 hrs	7.50 hrs	6.75 hrs	8.00 hrs	9.25 hrs
04/01/93	2.50 hrs	3.76 hrs	5.75 hrs	6.00 hrs	6.75 hrs	8.75 hrs
04/15/93	2.75 hrs	5.74 hrs	7.25 hrs	7.25 hrs	8.00 hrs	9.75 hrs
05/30/93	1.25 hrs	1.58 hrs	4.00 hrs	4.25 hrs	4.75 hrs	7.00 hrs
05/31/93	1.75 hrs	2.97 hrs	5.25 hrs	5.75 hrs	6.25 hrs	8.25 hrs
07/01/93	4.75 hrs	4.94 hrs	7.25 hrs	7.50 hrs	8.00 hrs	10.00 hrs
07/07/93	1.50 hrs	1.58 hrs	4.00 hrs	4.25 hrs	4.75 hrs	6.75 hrs
07/14/93	1.75 hrs	2.57 hrs	4.75 hrs	4.75 hrs	5.50 hrs	7.75 hrs

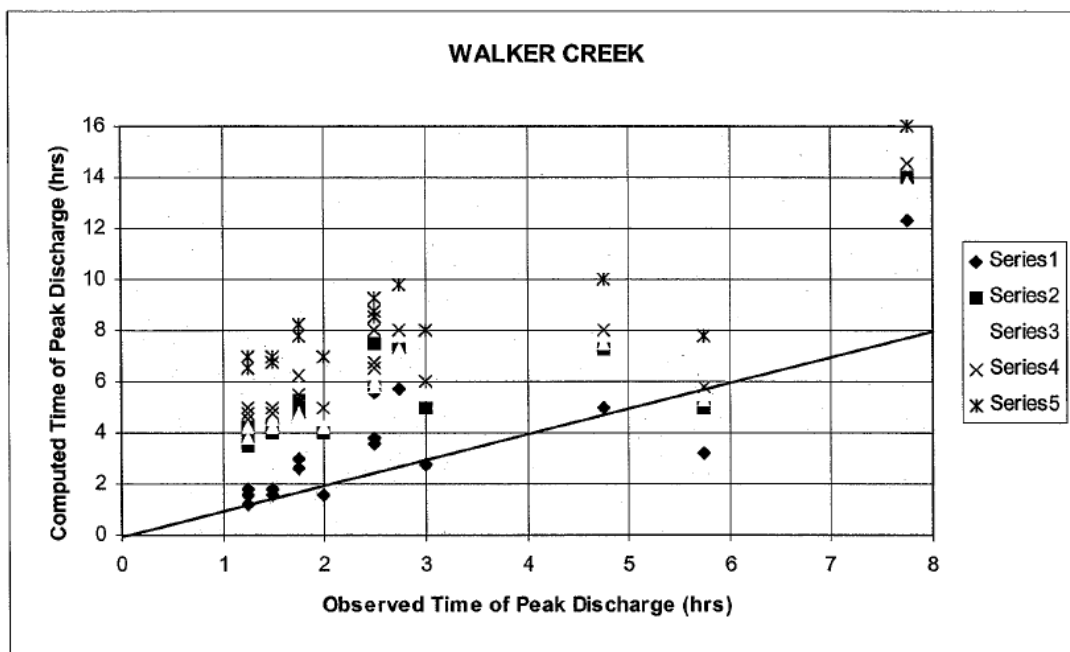

Table 2.2.1.9a - Comparison of Observed and Computed Peak Discharges - Clower Creek

Storm	Obs. Flow	Series 1 K=75 Tc=45 min	Series 2 K=256 Tc= 154 min	Series 3 K=284 Tc= 171 min	Series 4 K=323 Tc= 194 min	Series 5 K=484 Tc=291 min
03/30/92	20.8 cfs	9.9 cfs	9.7 cfs	11.3 cfs	10.2 cfs	11.6 cfs
07/12/92	36.3 cfs	41.3 cfs	41.3 cfs	42.0 cfs	42.0 cfs	43.1 cfs
07/22/92	43.2 cfs	43.8 cfs	44.0 cfs	44.9 cfs	45.0 cfs	45.7 cfs
08/14/92	19.1 cfs	10.4 cfs	5.7 cfs	5.7 cfs	5.7 cfs	5.8 cfs
09/02/92	64.0 cfs	54.2 cfs	54.8 cfs	56.0 cfs	56.0 cfs	56.7 cfs
09/04/92	38.4 cfs	31.8 cfs	31.7 cfs	31.8 cfs	32.1 cfs	32.2 cfs
09/13/92	108.2 cfs	122.1 cfs	121.7 cfs	125.7 cfs	125.1 cfs	127.9 cfs
01/14/93	40.7 cfs	40.2 cfs	39.5 cfs	43.6 cfs	41.5 cfs	44.3 cfs
01/15/93	34.7 cfs	22.2 cfs	22.4 cfs	24.3 cfs	23.0 cfs	25.4 cfs

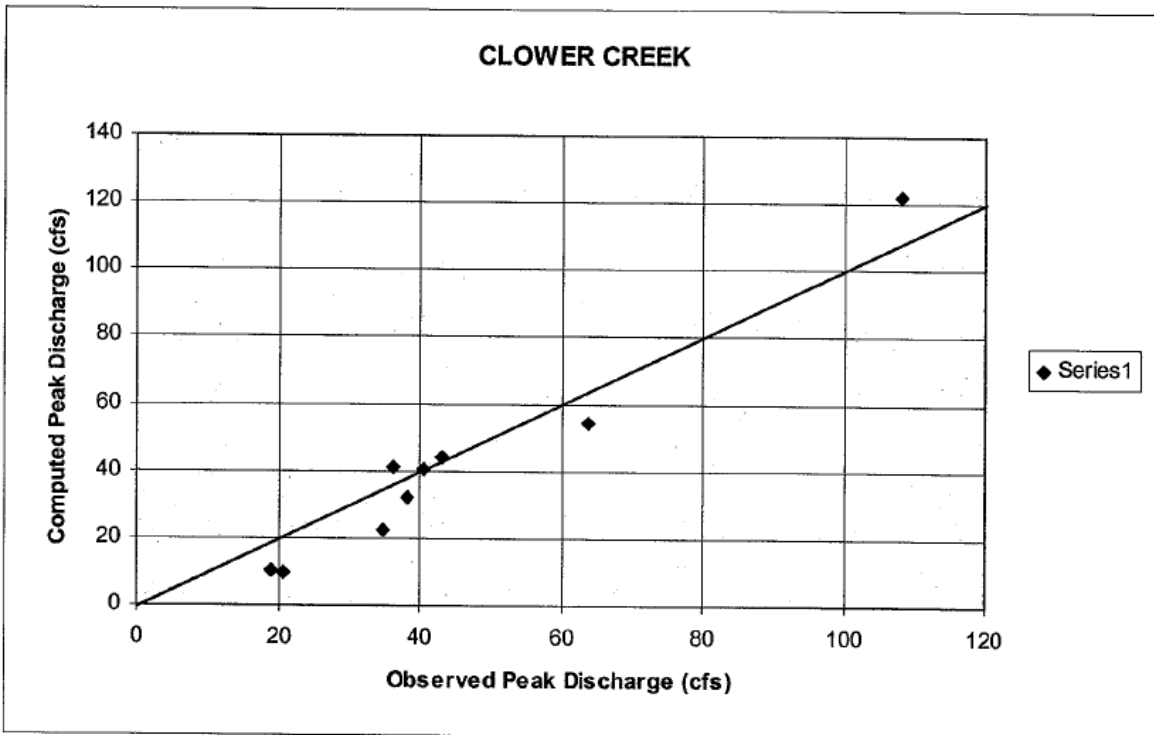



Table 1.0.1.9b - Comparison of Observed and Computed Peak Discharge Times - Clower Creek

Storm	Obs. TP	Series 1 K=75 Tc=45min	Series 2 K=256 Tc= 154min	Series 3 K=284 Tc= 171 min	Series 4 K=323 Tc= 194min	Series 5 K=484 Tc= 291 min
03/30/92	1.08 hrs	5.40 hrs	6.00 hrs	6.00 hrs	6.00 hrs	6.75 hrs
07/12/92	1.75 hrs	2.20 hrs	3.25 hrs	3.50 hrs	3.50 hrs	4.75 hrs
07/22/92	0.92 hrs	1.90 hrs	2.75 hrs	3.00 hrs	3.25 hrs	4.25 hrs
08/14/92	0.33 hrs	1.20 hrs	2.00 hrs	2.25 hrs	2.50 hrs	3.50 hrs
09/02/92	0.83 hrs	1.50 hrs	2.50 hrs	2.50 hrs	2.75 hrs	3.75 hrs
09/04/92	0.83 hrs	1.40 hrs	2.50 hrs	2.75 hrs	2.75 hrs	3.75 hrs
09/13/92	1.33 hrs	1.90 hrs	2.75 hrs	3.00 hrs	3.25 hrs	4.25 hrs
01/14/93	18.30 hrs	3.10 hrs	3.75 hrs	3.75 hrs	4.00 hrs	5.00 hrs
01/15/93	1.50 hrs	1.90 hrs	2.75 hrs	4.00 hrs	3.50 hrs	4.75 hrs

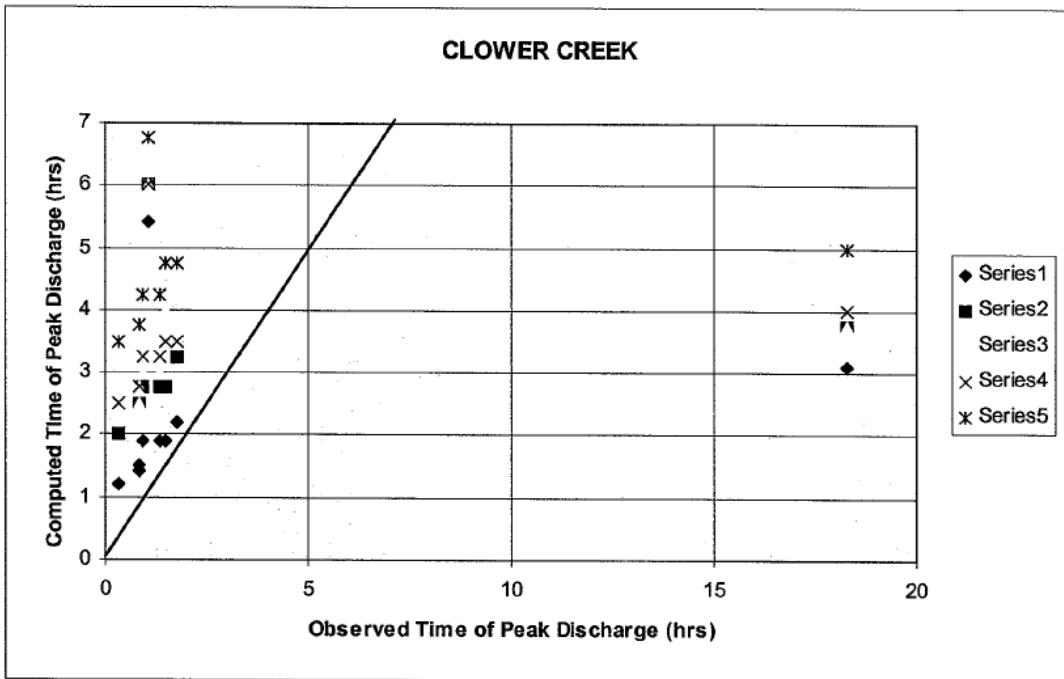

Table 1.0.1.10a - Comparison of Observed and Computed Peak Discharges - Catfish Creek

Storm	Obs. Flow	Series 1 K=75 Tc= 215 min	Series 2 K=256 Tc= 734 min	Series 3 K=284 Tc= 815 min	Series 4 K=323 Tc=927 min	Series 5 K=484 Tc= 1388 min
01/08/93	11 cfs	6 cfs	6 cfs	7 cfs	7 cfs	7 cfs
01/14/93	68 cfs	77 cfs	78 cfs	79 cfs	80 cfs	81 cfs
01/25/93	41 cfs	59 cfs	57 cfs	60 cfs	58 cfs	61 cfs
02/22/93	9 cfs	8 cfs	8 cfs	9 cfs	8 cfs	9 cfs
02/26/93	29 cfs	27 cfs	27 cfs	27 cfs	27 cfs	27 cfs
03/03/93	5 cfs	9 cfs	9 cfs	9 cfs	9 cfs	9 cfs
03/13/93	133 cfs	94 cfs	95 cfs	97 cfs	97 cfs	98 cfs
04/01/93	301 cfs	306 cfs	305 cfs	313 cfs	313 cfs	317 cfs
04/05/93	61 cfs	49 cfs	49 cfs	49 cfs	49 cfs	49 cfs
04/15/93	83 cfs	74 cfs	75 cfs	76 cfs	76 cfs	76 cfs
07/31/93	21 cfs	9 cfs	9 cfs	9 cfs	9 cfs	9 cfs
08/16/93	31 cfs	24 cfs	24 cfs	24 cfs	24 cfs	24 cfs
08/30/93	44 cfs	49 cfs	48 cfs	48 cfs	48 cfs	48 cfs
09/13/93	62 cfs	74 cfs	74 cfs	75 cfs	75 cfs	75 cfs

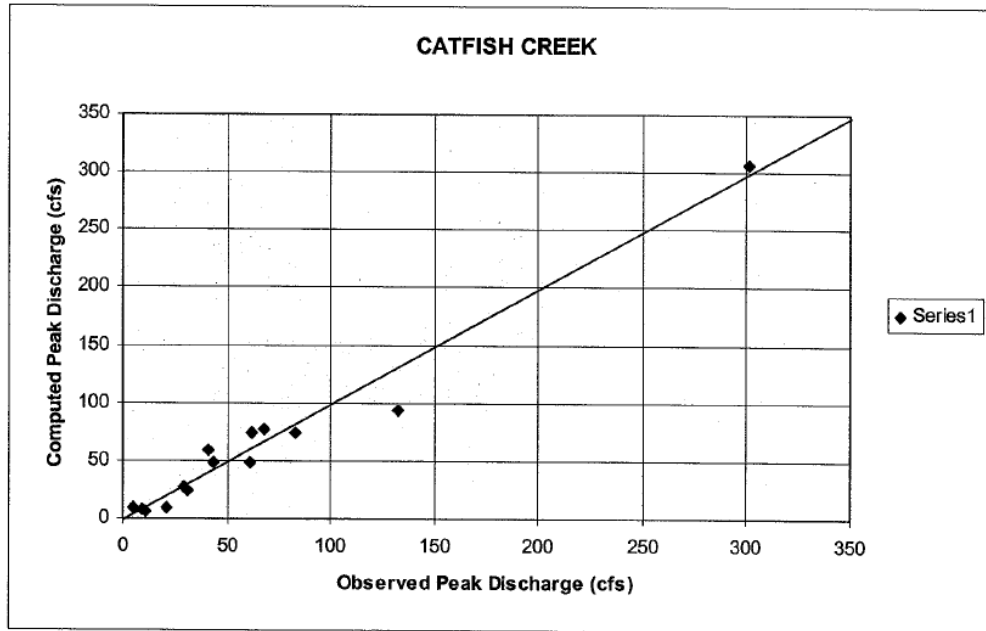

Table 1.0.1.10b - Comparison of Observed and Computed Peak Discharge Times - Catfish Creek

Storm	Obs. TP	Series 1 K=75 Tc= 215 min	Series 2 K=256 Tc=734 min	Series 3 K=284 Tc= 815 min	Series 4 K=323 Tc=927 min	Series 5 K=484 Tc= 1388 min
01/08/93	7.00 hrs	13.50 hrs	15.25 hrs	16.25 hrs	17.00 hrs	21.75 hrs
01/14/93	34.00 hrs	35.00 hrs	39.50 hrs	39.50 hrs	41.50 hrs	47.00 hrs
01/25/93	23.00 hrs	21.50 hrs	26.50 hrs	26.50 hrs	28.00 hrs	32.25 hrs
02/22/93	4.50 hrs	7.00 hrs	11.50 hrs	11.75hrs	13.00 hrs	17.50 hrs
02/26/93	5.25 hrs	4.50 hrs	10.25 hrs	11.00 hrs	12.25 hrs	17.50 hrs
03/03/93	6.00 hrs	3.50 hrs	9.25 hrs	10.00 hrs	11.25 hrs	16.25 hrs
03/13/93	4.75 hrs	4.00 hrs	9.75 hrs	10.50 hrs	12.00 hrs	17.25 hrs
04/01/93	3.75 hrs	6.25 hrs	11.25 hrs	11.50 hrs	13.25 hrs	18.00 hrs
04/05/93	5.50 hrs	4.50 hrs	10.25 hrs	11.00 hrs	12.25 hrs	17.25 hrs
04/15/93	13.25 hrs	7.00 hrs	12.00 hrs	12.50 hrs	14.00 hrs	19.00 hrs
07/31/93	7.25 hrs	3.25 hrs	9.00 hrs	9.75 hrs	11.00 hrs	16.25 hrs
08/16/93	4.25 hrs	3.00 hrs	8.75 hrs	9.75 hrs	11.00 hrs	16.00 hrs
08/30/93	23.00 hrs	17.75 hrs	23.75 hrs	24.50 hrs	25.50 hrs	29.75 hrs
09/13/93	5.75 hrs	4.75 hrs	9.50 hrs	10.25 hrs	11.75 hrs	16.75 hrs

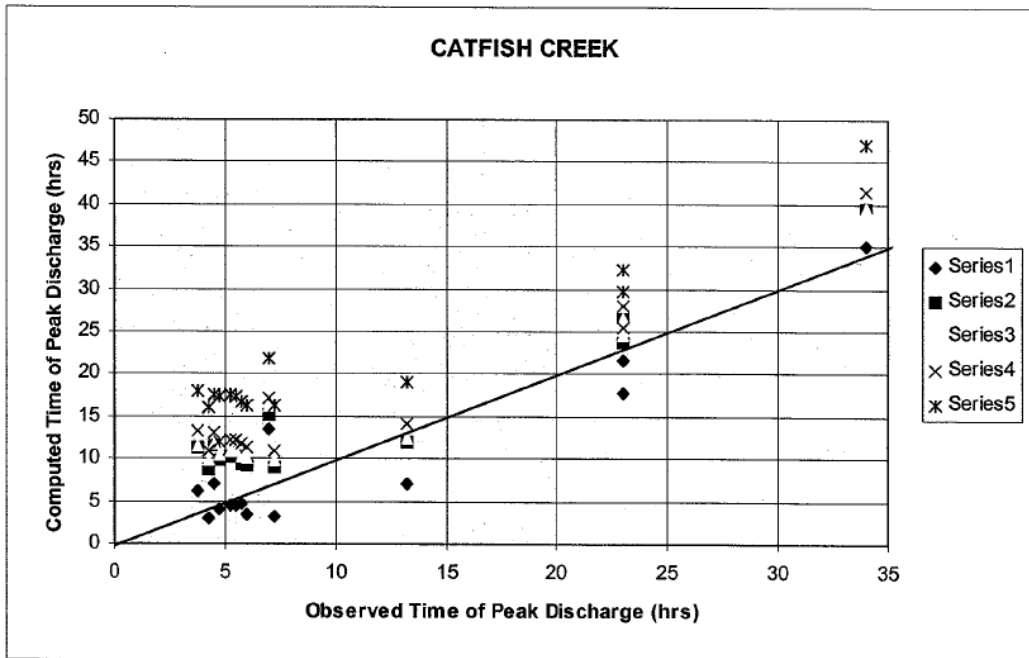

Table 1.0.1.1la - Comparison of Observed and Computed Peak Discharges - South Creek

Storm	Obs. Flow	Series 1 K=75 Tc=447 min	Series 2 K=256 Tc= 1527 min	Series 3 K=284 Tc= 1694 min	Series 4 K=323 Tc= 1927 min	Series 5 K=484 Tc= 2887 min
03/12/93	7.3 cfs	9.3 cfs	9.1 cfs	9.4 cfs	9.3 cfs	9.5 cfs
04/01/93	18.6 cfs	22.8 cfs	22.7 cfs	22.8 cfs	22.9 cfs	22.9 cfs
04/15/93	6.8 cfs	8.4 cfs	8.3 cfs	8.4 cfs	8.4 cfs	8.4 cfs
03/01/94	5.2 cfs	5.1 cfs	5.1 cfs	5.1 cfs	5.1 cfs	5.1 cfs
10/13/94	9.2 cfs	9.3 cfs	9.2 cfs	9.3 cfs	9.3 cfs	9.3 cfs

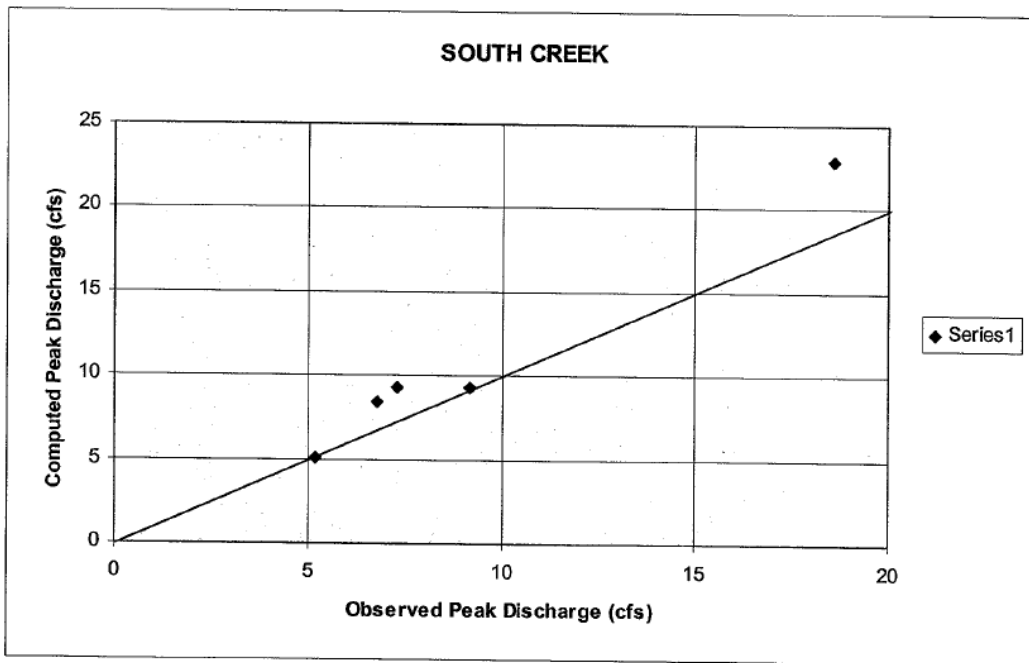

Table 1.0.1.11b - Comparison of Observed and Computed Peak Discharge Times - South Creek

Storm	Obs. TP	Series 1 K=75 Tc=447 min	Series 2 K=256 Tc= 1527 min	Series 3 K=284 Tc= 1694 min	Series 4 K=323 Tc= 1927 min	Series 5 K=484 Tc=2887 min
03/12/93	13 hrs	16.25 hrs	28.0 hrs	29.50 hrs	31.75 hrs	42.25 hrs
04/01/93	8 hrs	11.75 hrs	23.5 hrs	25.25 hrs	27.75 hrs	38.25 hrs
04/15/93	13 hrs	9.25 hrs	21.5 hrs	23.00 hrs	25.00 hrs	35.75 hrs
03/01/94	11 hrs	16.50 hrs	28.5 hrs	30.25 hrs	32.75 hrs	43.50 hrs
10/13/94	16 hrs	8.50 hrs	20.5 hrs	22.25 hrs	24.75 hrs	35.50 hrs

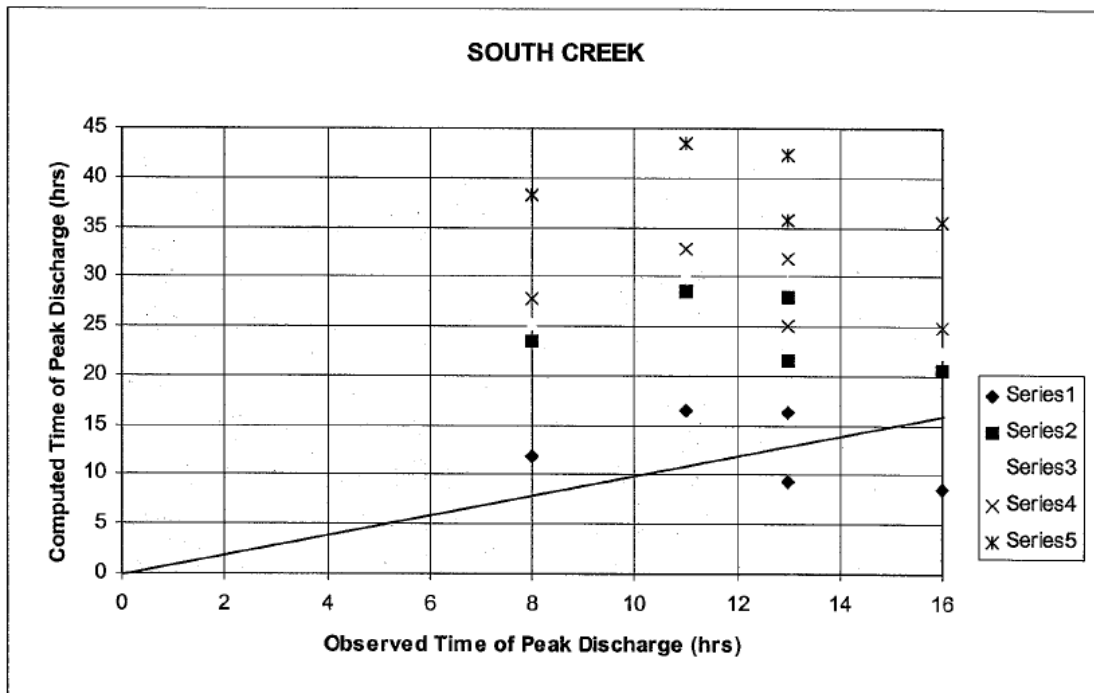

Table 1.0.1.12a - Comparison of Observed and Computed Peak Discharges - Gottfried Creek

Storm	Obs. Flow	Series 1 K=75 Tc =548 min	Series 2 K=256 Tc= 1872 min	Series 3 K=284 Tc=2076min	Series 4 K=323 Tc=2362 min	Series 5 K=484 Tc=3539 min
06/24/92	118 cfs	122 cfs	120 cfs	135 cfs	124 cfs	134 cfs
08/09/92	20 cfs	19 cfs	18 cfs	19 cfs	18 cfs	19 cfs
08/11/92	17 cfs	14 cfs	14 cfs	15 cfs	15 cfs	15 cfs
10/02/92	2 cfs	3 cfs	3 cfs	3 cfs	3 cfs	3 cfs
01/08/93	4 cfs	2 cfs	2 cfs	2 cfs	2 cfs	2 cfs
03/13/93	2 cfs	1 cfs	1 cfs	1 cfs	1 cfs	1 cfs
03/17/93	2 cfs	2 cfs	2 cfs	2 cfs	2 cfs	2 cfs
04/01/93	3 cfs	2 cfs	2 cfs	2 cfs	2 cfs	2 cfs
04/15/93	1 cfs	1 cfs	1 cfs	1 cfs	1 cfs	1 cfs

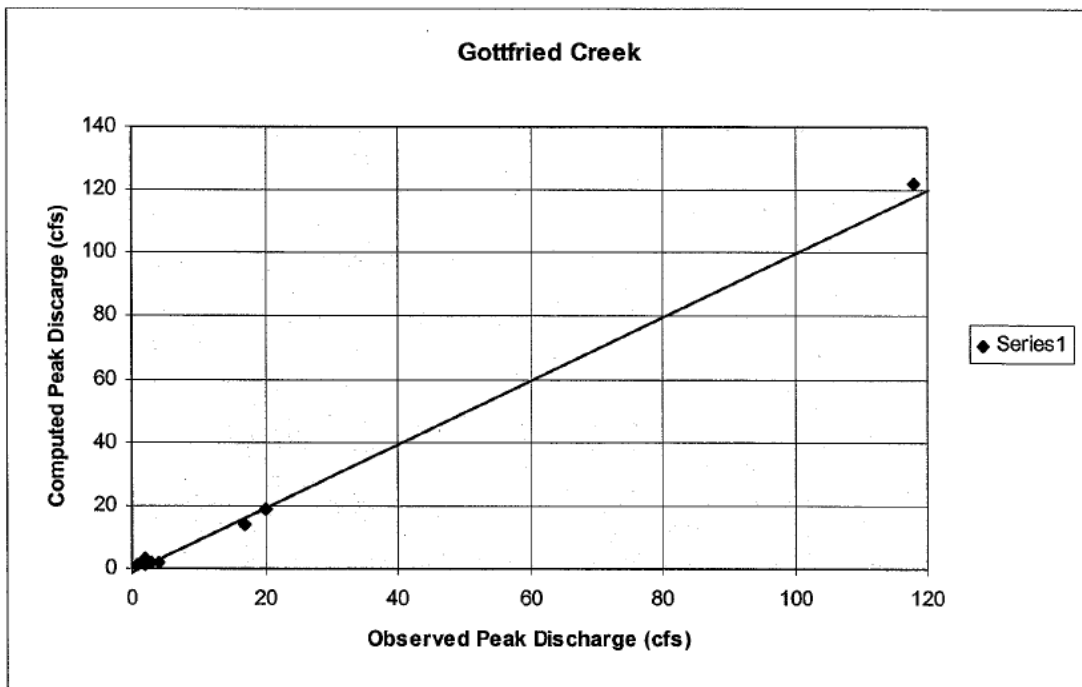
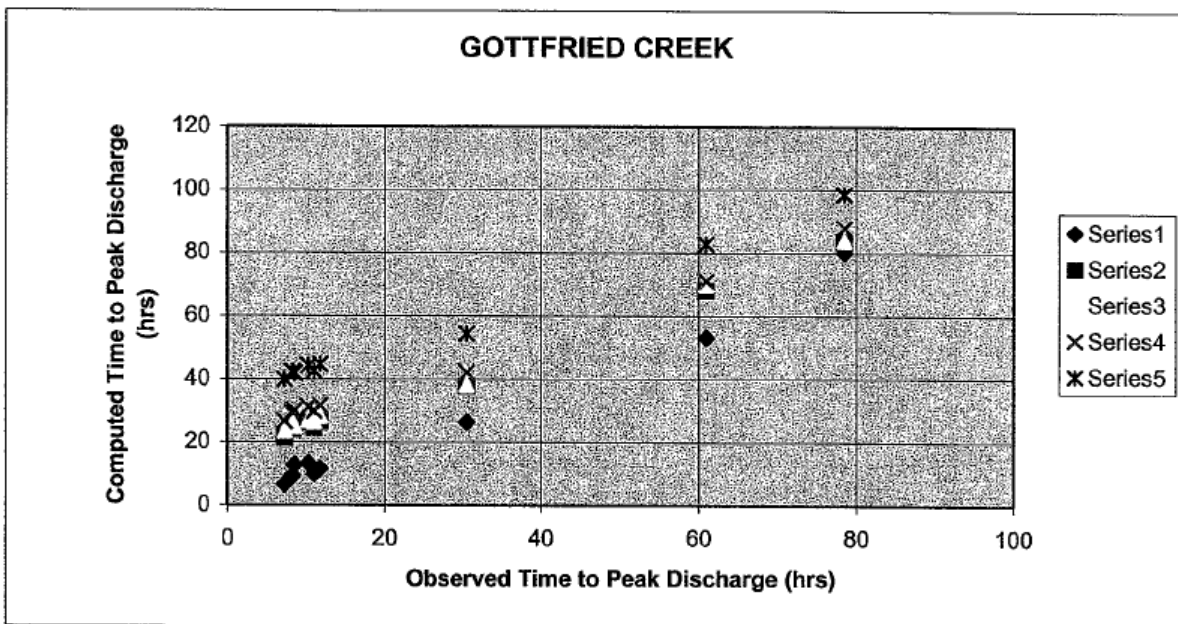

Table 1.0.1.12b - Comparison of Observed and Computed Peak Discharge Times - Gottfried Creek

Storm	Obs. TP	Series 1 <b>K=75</b> Tc=548 min	Series 2 <b>K=256</b> Tc= 1872 min	Series 3 <b>K=284</b> Tc=2076 min	Series 4 <b>K=323</b> Tc=2362 min	Series 5 <b>K=484</b> Tc=3539 min
06/24/92	78.50 hrs	80.00 hrs	83.50 hrs	84.00 hrs	87.75 hrs	98.50 hrs
08/09/92	61.00 hrs	53.00 hrs	68.00 hrs	70.00 hrs	71.00 hrs	82.75 hrs
08/11/92	30.50 hrs	26.25 hrs	37.75 hrs	38.25 hrs	42.00 hrs	54.25 hrs
10/02/92	10.25 hrs	13.25 hrs	26.25 hrs	27.00 hrs	31.00 hrs	44.25 hrs
01/08/93	8.50 hrs	12.75 hrs	25.00 hrs	25.00 hrs	30.00 hrs	41.75hrs
03/13/93	11.75 hrs	11.50 hrs	26.50 hrs	28.25 hrs	31.50 hrs	44.50 hrs
03/17/93	8.25 hrs	9.25 hrs	24.00 hrs	26.00 hrs	29.25 hrs	42.25 hrs
04/01/93	11.00 hrs	9.75 hrs	24.50 hrs	26.50 hrs	29.75 hrs	42.50 hrs
04/15/93	7.25 hrs	6.50 hrs	21.25 hrs	23.50 hrs	26.50 hrs	39.75 hrs



Other observations that are not necessarily evident from the previous tables are noted below:

- The finding that a K of 75 consistently provided the closest match of observed runoff hydrographs for all the study areas indicates that peak rate factors may be more related to regional hydrologic response characteristics (i.e. topographic relief, depression storage) and not land use or drainage characteristics.
- Land use and drainage characteristics are likely responsible for significant reductions in the time of concentration and therefore, more responsive runoff hydrographs.
- Overall, runoff hydrographs computed using a K of 75 provided the closest generalized shape when compared to the observed hydrographs.
- In general, the NRCS unit hydrograph did not perform well for storms which produced low runoff volumes.

Based on the work of Capece and others (1986), the South Florida Water Management District (SFWMD) recommends using a peak rate factor of 100 for subbasins with slopes less than about 5 feet per mile (0.1 percent). The majority of the rural subbasins in Phillippi Creek fall into this category. For subbasins with slopes greater than 5 feet per mile, SFWMD recommends using 256.

#### TIME OF CONCENTRATION

The time of concentration (TC) for each subbasin was computed using the Manning's kinematic solution as outlined in SCS Technical Release 55. In this approach, the TC is computed by summing the travel times for the sheet flow, shallow concentrated flow, and open channel flow components of the drainage system from the hydraulically most distant point to the receiving node.

For sheet flow of less than 300 feet, the following form of Manning's kinematic solution was used:

$$T_t = \frac{0.007 (nL)^{0.8}}{(P_2)^{0.5} s^{0.4}}$$

where

- $T_t$  = travel time (hr),
- $n$  = Manning's roughness coefficient
- $L$  = Flow length (ft)
- $P_2$  = 2-year, 24-hour rainfall (in), and
- $s$  = slope of hydraulic grade line (land slope, ft/ft)

The following formulas from SCS TR-55 were used to compute the velocity, (V in feet per second) of shallow concentrated flow:

Unpaved:	$V = 16.1345(s)^{0.5}$
Paved:	$V = 20.3282(s)^{0.5}$



## 2.2.1 HYDRAULICS

The unsteady flow routing model contained within ICPR version 2.11 was utilized for the simulation. This model is accepted by FEMA and is well suited for use in low-relief watersheds such as those found in coastal Florida. A full description of the computational procedures can be found within the ICPR User's Manual (Singhofen and Eaglin, 1995). It should be noted that due to the large number of nodes and reaches, the authors of the software have compiled a special version of the software to be able to accommodate the large array sizes necessary to run the model and view the results. Streamline Technologies, Inc. has stated that the 5,000-node large array version will soon be available free of charge to licensed "unlimited node" ICPR users.

### MANNING'S "N"

Field reconnaissance was conducted of every significant open channel reach in the model. In order to document channel conditions and vegetative growth towards the end of the growing season (which naturally coincides with the rainy season), color photographs will be taken at crossings and other locations during the wet season. These photographs will be kept on file in a binder at the County Stormwater Division.

To aid in determination of Manning's  $n$ , Cowan's equation was consulted (Arcement and Schneider, 1984):

$$n=(n_b + n_1 + n_2 + n_3 + n_4) m$$

where:  $n_b$  = a base value of  $n$  for a straight uniform, smooth channel in natural materials;

$n_1$  = a value added to correct for the effect of surface irregularities;

$n_2$  = a value for variations in shape and size of the channel cross section;

$n_3$  = a value for obstructions;

$n_4$  = a value for vegetation and flow conditions;

and  $m$  = a correction factor for meandering of the channel.

Other references consulted on Manning's  $n$  determination are fully documented in the bibliography at the end of this report and include Chow (1959), and Barnes (1967).

### BRIDGES

The bridge modeling routines in ICPR directly incorporate the code from the one-dimensional, steady-flow model WSPRO (Shearman et. al., 1986). Prior to execution of the ICPR simulation, ICPR uses the bridge input data to create a series of WSPRO input files with several user-specified combinations of tailwater and flow rate, to cover the anticipated range of flows and stages. ICPR then executes the WSPRO routines to generate a family of headwater-discharge rating curves for each user-specified tailwater elevation. It is this family of rating curves that is used in the dynamic ICPR simulation, with a double-linear interpolation performed between curves and data points on the curves.

# **Attachment 11**

## **Unit Hydrographs**

## NON-DIMENSIONAL UNIT HYDROGRAPHS

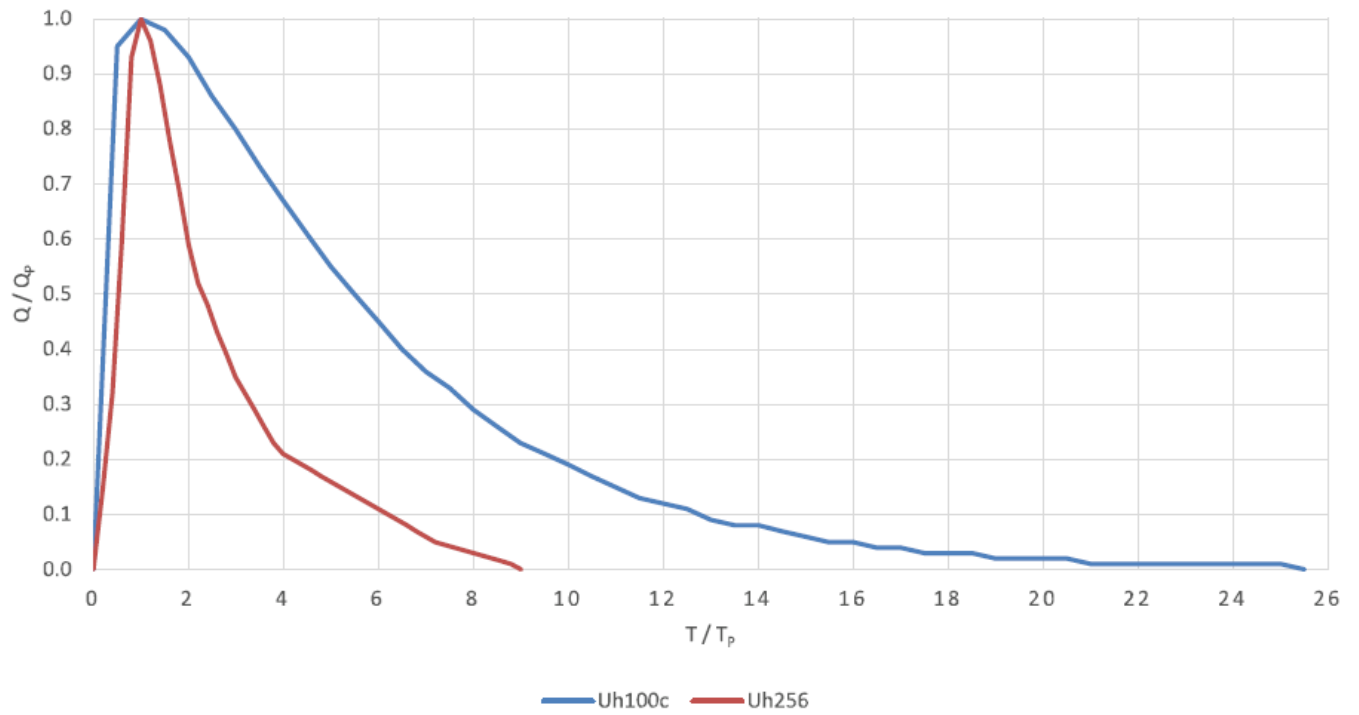

UH100C				UH256			
T/Tp	Q/Qp	T/Tp	Q/Qp	T/Tp	Q/Qp	T/Tp	Q/Qp
0.000	0.000	12.500	0.110	0.000	0.000	5.000	0.160
0.500	0.950	13.000	0.090	0.200	0.150	5.200	0.150
1.000	1.000	13.500	0.080	0.400	0.320	5.400	0.140
1.500	0.980	14.000	0.080	0.600	0.600	5.600	0.130
2.000	0.930	14.500	0.070	0.800	0.930	5.800	0.120
2.500	0.860	15.000	0.060	1.000	1.000	6.000	0.110
3.000	0.800	15.500	0.050	1.200	0.960	6.200	0.100
3.500	0.730	16.000	0.050	1.400	0.880	6.400	0.090
4.000	0.670	16.500	0.040	1.600	0.780	6.600	0.080
4.500	0.610	17.000	0.040	1.800	0.690	6.800	0.070
5.000	0.550	17.500	0.030	2.000	0.590	7.000	0.060
5.500	0.500	18.000	0.030	2.200	0.520	7.200	0.050
6.000	0.450	18.500	0.030	2.400	0.480	7.400	0.045
6.500	0.400	19.000	0.020	2.600	0.430	7.600	0.040
7.000	0.360	19.500	0.020	2.800	0.390	7.800	0.035
7.500	0.330	20.000	0.020	3.000	0.350	8.000	0.030
8.000	0.290	20.500	0.020	3.200	0.320	8.200	0.025
8.500	0.260	21.000	0.010	3.400	0.290	8.400	0.020
9.000	0.230	21.500	0.010	3.600	0.260	8.600	0.015
9.500	0.210	22.000	0.010	3.800	0.230	8.800	0.010
10.000	0.190	22.500	0.010	4.000	0.210	9.000	0.000
10.500	0.170	23.000	0.010	4.200	0.200		
11.000	0.150	23.500	0.010	4.400	0.190		
11.500	0.130	24.000	0.010	4.600	0.180		
12.000	0.120	24.500	0.010	4.800	0.170		
		25.000	0.010				
		25.500	0.000				

**Attachment 12**  
**ICPR4 Input Data**  
**Comparator Documentation**

## Updates to Watershed Models, Stormwater Manual, and Software Model Review Tools

**TO:** Robert Laura, PE (Sarasota County)

**FROM:** Khan Boupha, PE; Jason Icerman, PE; Brett Cunningham, PE

**DATE:** July 11, 2022

**SUBJECT:** Documentation and User Guide for Interconnected Channel and Pond Routing  
Version 4 (ICPR4) Model Comparison Tool  
Jones Edmunds Project No. 19006-066-01

---

### 1 PURPOSE

Sarasota County requested that Jones Edmunds develop an *ICPR4 Model Comparison Tool*. The Tool is similar to the ICPR3 Model Comparison Tool Jones Edmunds developed for Sarasota County that was commonly referred to simply as a *Comparator*. The ICPR4 Comparator operates against ICPR4 comma-separated values (CSV) files developed for use with SWFWMD's GWIS database schema and compares model input data between two sets of CSV files representing two ICPR4 models. The ICPR4 Comparator does not check model results.

The ICPR4 Comparator was developed specifically to aid the County in identifying changes to model data between existing conditions, revised existing conditions, and proposed conditions such as is necessary during the County's Stormwater Review of proposed land development. The ICPR4 Comparator identifies differences in the CSV files and reports these differences as either an Addition, Modification, or Deletion. The Addition, Modification, Deletion terminology is based on the model element name whereas elements with different data, but the same name are referred to as Modifications and model elements with different names are referred to as Additions and Deletions.

### 2 INSTRUCTIONS

The ICPR4 Comparator has been developed to be simple and houses results within a Microsoft Excel file. The ICPR4 Comparator is installed via a standalone executable file named *ICPR4CompareSetup.exe*, which can be installed without administrative rights for individual Windows 10 user accounts. However, users should have Microsoft Excel installed and most users will also need to install the Microsoft Access Database Engine 2010 Redistributable, which can be downloaded from Microsoft and does require administrative rights for installation. As of October 2020, the Microsoft Access Database Engine 2010 Redistributable was available for download at the following link: <https://www.microsoft.com/en-us/download/details.aspx?id=13255>.

As with all third-party stand-alone executables, users should take standard precautions when copying files between machines, first time runs on a machine, etc. The ICPR4 Comparator has been successfully tested by Jones Edmunds on multiple machines using the Windows 10 operating system and Microsoft Office 365.

Following installation users can access the ICPR4 Comparator either by a shortcut created on the desktop or within the start menu *ICPR4Compare* and following the steps below:

1. Double-click or Right-click “Run” the ICPR4Compare.
2. Navigate and select the directory containing ICPR4 CSV files for the models you would like to compare via the Browse buttons (Figure 1).
3. Click Compare Now. You will be prompted to identify a file location to save the excel file which houses the results of the ICPR4 Comparator. If you receive an error at this step after first installation, you likely need to install the Microsoft Access Database Engine 2010 Redistributable.
4. When the ICPR4 Comparator is complete, the excel file will automatically open to review the results.

**Figure 1 The ICPR4 Comparator After Loading Model Data**

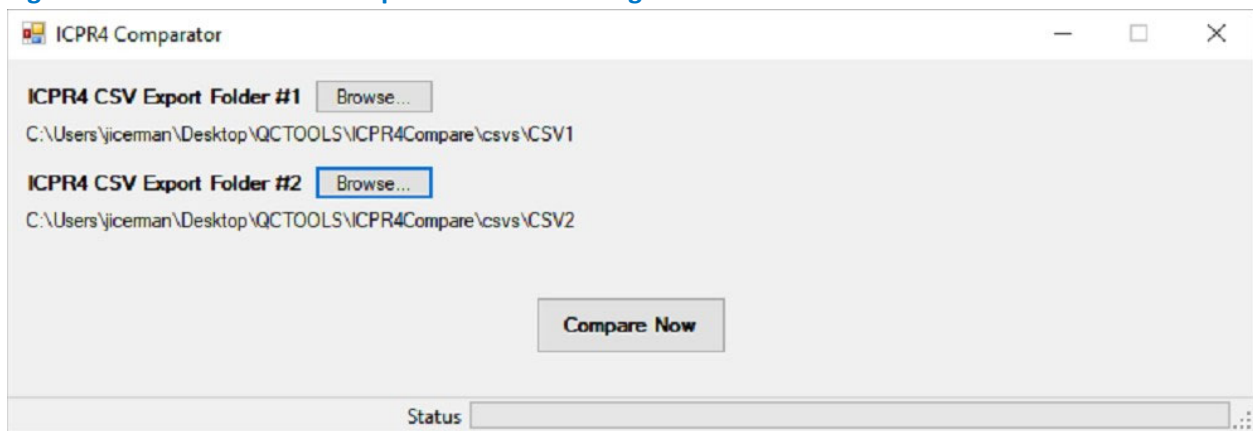

ICPR4 CSV files must be generated for use with SWFWMD’s GWIS database schema. These CSV files can be generated from a GWIS database or ICPR4. Figure 2 shows ICPR4 (version 4.07.04) where the GWIS CSV export is available under File→Export→GWIS.

**Figure 2 The ICPR4 GUI Showing GWIS Export and CSV Location Selection**

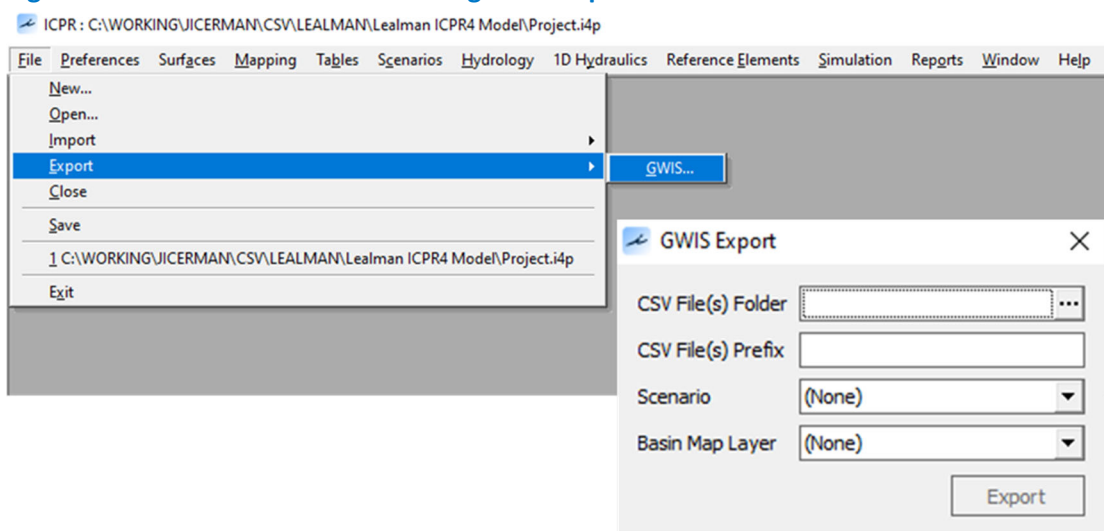

### 3 MODEL COMPARISON EXCEL OUTPUT

The ICPR4 Comparator output is housed in an Excel Workbook which includes 10 model element sheets and 3 summary sheets as listed below. Figure 3 displays an example Basin Modification and generally represents a model element sheet. Figure 4 displays an example Basin Summary and generally represent a summary sheet. The figures are provided as examples to represent all comparison sheets, which will have a similar visual appearance.

#### Model Element Sheets

- Basins
- Nodes
- Pipes
- Drop Structures
- Channels
- Channel Cross-sections
- Weirs
- Weir Cross-sections
- Rating Curves
- Operating Tables

#### Summary Sheets

- Basin Summary
- Node Summary
- Link Summary

**Figure 3 Example Model Element Comparison Sheet**

		EXISTING	REVISED
		Name 80805	Name 80805
		Node 80805	Node 80805
		Hydrograph Method 0	Hydrograph Method 0
		Infiltration Method 0	Infiltration Method 0
		Time-of-Concentration (hrs) 10	Time-of-Concentration (hrs) 10
		Max Allowable Q (cfs) 999999	Max Allowable Q (cfs) 999999
		Time Shift (hrs) 0	Time Shift (hrs) 0
		Unit Hydrograph UH256	Unit Hydrograph UH256
		Peaking Factor 256	Peaking Factor 256
		Area (ac) 0.41	Area (ac) 0.41
		Curve Number 80.2	Curve Number 85
		Pct Impervious (%) 16.3	Pct Impervious (%) 16.3
		Pct DCIA (%) 16.3	Pct DCIA (%) 16.3
		Pct Direct (%) 0	Pct Direct (%) 0
		Rainfall Name 79946	Rainfall Name 79946
		Comment	Comment

**Figure 4**      **Example Summary Sheet**

BasinName	Added	Deleted	Modified
80805			X
80813		X	
80814	X		
80833			X
80834			X
80837			X
80840			X
80854			X
80855			X
80888			X

## 4 SUMMARY

The *ICPR4 Model Comparison Tool* was developed to aid users in reviewing ICPR4 model data by comparing model input data for two models based on GWIS-schema CSV files. The Tool has been developed to be simple to use and produce results in a similar format to the County’s ICPR3 Model Comparison Tool. The Tool does not check model results. At the time of development, the most recent version of ICPR4 was version 4.07.08, released in February 2021.



**Attachment 13**  
**ICPR4 Input Data**  
**QC Tool Documentation**

## Updates to Watershed Models, Stormwater Manual, and Software Model Review Tools

**TO:** Robert Laura, PE (Sarasota County)

**FROM:** Khan Boupcha, PE; Jason Icerman, PE; Brett Cunningham, PE

**DATE:** July 14, 2021

**SUBJECT:** Documentation and User Guide for Interconnected Channel and Pond Routing Version 4 (ICPR4) Data Input Quality Control Checks Tool  
Jones Edmunds Project No. 19006-066-01

---

### 1 PURPOSE

Sarasota County requested that Jones Edmunds develop an *ICPR4 Data Input Quality Control Checks Tool*. The Tool is to aid users in reviewing ICPR4 model inputs by performing checks of model input data. When using this tool, model input data are checked for reasonableness against typical parameter ranges and against other input data within the model. The Tool was developed for hydrologic inputs known in ICPR4 as Simple Basins and does not check Manual Basin inputs.

The Tool is not a substitute for other quality control measures that may be employed during model development. Accordingly, reported results should be viewed as targeting model input data for further investigation, not as a binary right-versus-wrong determination. Tool users, such as model developers or reviewers, should make any final determinations of data acceptance for model input data as reported by the Tool. Similarly, not all potential errors in input data will be reported by the Tool. In practice, users should expect well-developed models to have some, but few, records reported by the Tool.

The Tool does not check model results.

### 2 INSTRUCTIONS

The Tool has been developed to be simple. The Tool is installed via a standalone executable file named *ICPR4QCSetup.exe*, which can be installed without administrative rights for individual Windows 10 user accounts. However, most users will also need to install the Microsoft Access Database Engine 2010 Redistributable, which can be downloaded from Microsoft and does require administrative rights for installation. As of October 2020, the Microsoft Access Database Engine 2010 Redistributable was available for download at the link below.

<https://www.microsoft.com/en-us/download/details.aspx?id=13255>

As with all third-party stand-alone executables, users should take standard precautions when copying files between machines, first time runs on a machine, etc. The Tool has been successfully tested by Jones Edmunds on multiple machines using the Windows 10 operating system.

Following installation users can access the Tool either by a shortcut created on the desktop or within the start menu *ICPR4QC* and following the steps below:

1. Double-click or Right-click “Run” the ICPR4QC.
2. Via the File dropdown menu, navigate and select the directory containing ICPR4 comma-separated values (CSV) files for the model you would like to review. If you receive an error at this step after first installation, you likely need to install the Microsoft Access Database Engine 2010 Redistributable.
3. Select the report of interest from the drop-down menu OR navigate through all reports using the arrow keys OR export all the results to an excel file using the *Export to Excel* button.

## 2.1 TOOL GRAPHICAL USER INTERFACE (GUI) EXAMPLES

**Figure 1** The Tool GUI When Selecting the CSV Directory Location

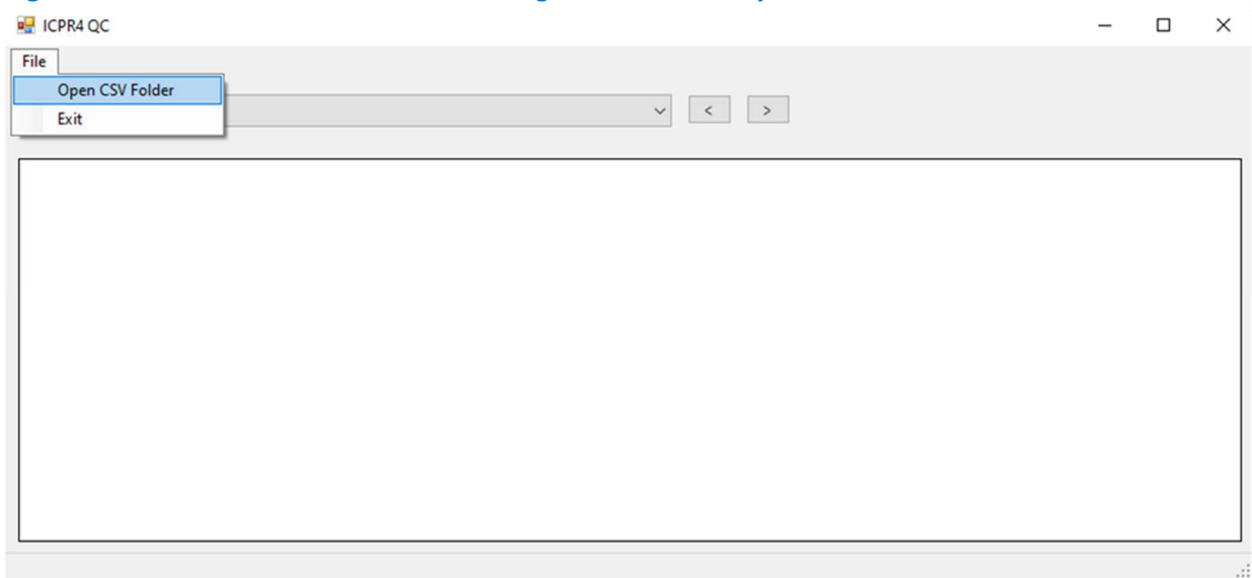

**Figure 2** The Tool GUI Showing Results of Quality Report #2

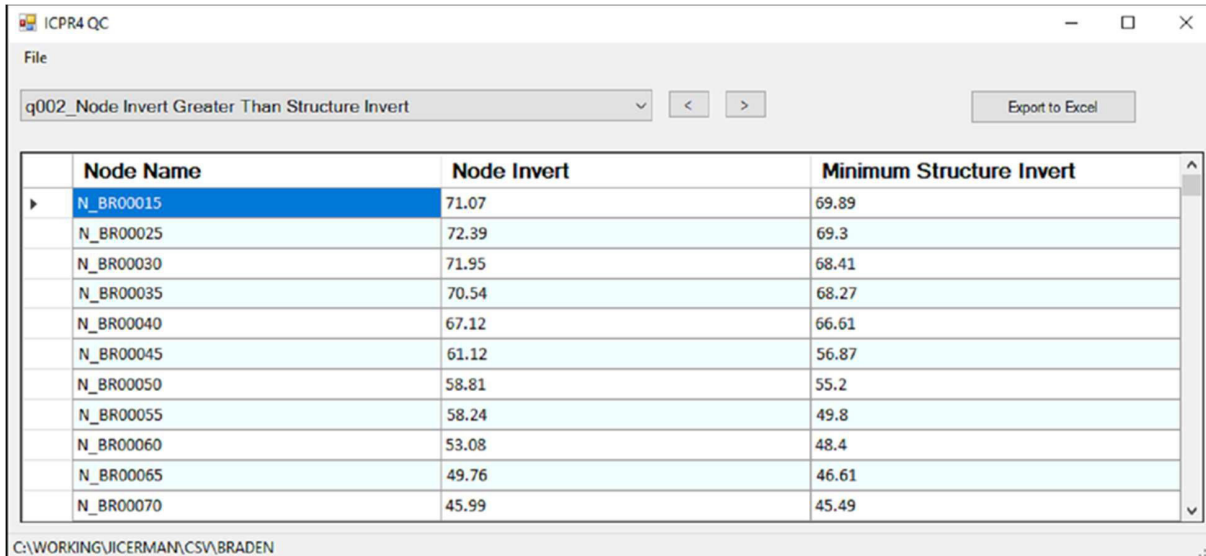

## 2.2 GENERATE ICPR4 CSVs

ICPR4 CSV files must be generated for use with SWFWMD's GWIS database schema. These CSV files can be generated from a GWIS database or ICPR4. Figure 3 shows ICPR4 (version 4.07.04) where the GWIS CSV export is available under File→Export→GWIS.

**Figure 3 The ICPR4 GUI Showing GWIS Export and CSV Location Selection**

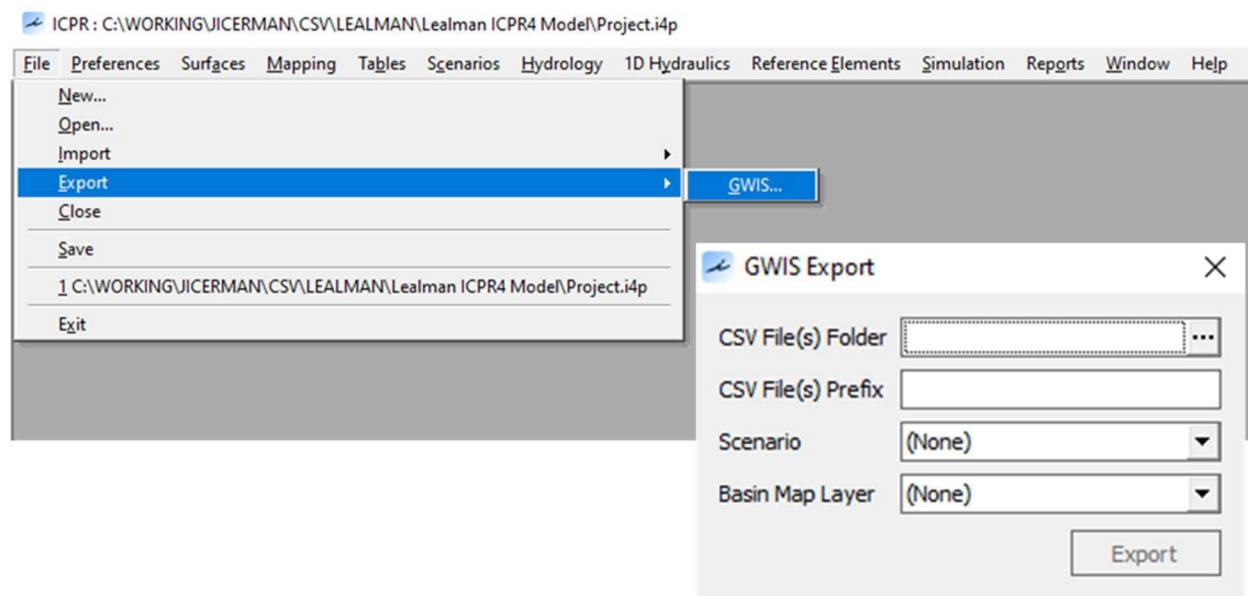

## 3 INPUT DATA REPORTS AND CHECKS

The Tool generates 13 Quality Reports. Some reports include more than one Quality Check. Table 1 describes the purpose of each report, input data checks performed, input data reported, and recommendations for assessing the input data reported.

## 4 SUMMARY

The *ICPR4 Data Input Quality Control Checks Tool* was developed to aid users in reviewing ICPR4 model data by performing checks of model input data based on GWIS-schema CSV files generated by ICPR4. At the time of development, the most recent version of ICPR4 was version 4.07.08, released in February 2021. The Tool does not check Manual Basin input data nor model results.

The Tool has been developed to be simple. Generally, the Tool performs the checks below, which should be performed before each new model simulation:

- Node State-Area Relationships versus Basin Area and Link Inverts.
- Potential Link Flows at Simulation Start (Initial Flows).
- Potential Link Flows versus Adjacent Connectivity (Weir Flow versus Pipe and Drop Structure Flow).
- Link Parameters versus Typical Value Ranges.

The Tool is not a substitute for other quality control measures that should be employed during model development. Reported results should be viewed as targeting model input data for further investigation, not as a binary right-versus-wrong determination.

**Table 1** Tool Quality Reports and Quality Checks

Report Number	Report Title	Purpose	Input Data Check(s) Performed	Reported Model Data	Recommended Action(s)
1	Node Storage Area Greater Than Basin Area	Review modeled node storage. Nodes with potential excess surface storage are reported.	Maximum Area from Node Stage-Area Relationship > Basin Area  <i>For Nodes Type Stage/Area with assigned Basin Hydrology Only.</i>	Node Name Basin Area Maximum Node Storage Area Percent Difference <sup>1</sup>	Reported nodes should be reviewed. Node areas only slightly larger than basin areas may be acceptable.
2	Node Invert Greater Than Structure Invert	Review modeled node storage. Nodes with potential lack of storage near hydraulic structure inverts are reported.	Lowest Stage from Node Stage-Area Relationship > Lowest Link Invert at Node  <i>For Nodes Type Stage/Area Only. All Links.</i>	Node Name Node Invert Minimum Structure Invert at Node	Reported nodes should be updated. Node inverts should be at or below structure inverts for optimum model stability.
3	Initial Stage Less Than Node Invert	Review model initial stage. Nodes with initial stage set below node storage values are reported.	Node Initial Stage < Lowest Stage from Node Stage-Area Relationship  <i>For Nodes Type Stage/Area Only.</i>	Node Name Initial Stage Node Invert	Reported nodes should be updated. Node initial stages should be at or above node inverts for optimum model stability.
4	Initial Flow in Pipes	Review initial flow in pipe links. Pipe links with potential initial flows are reported.	Upstream Node Initial Stage > Link Upstream Invert Downstream Node Initial Stage > Link Downstream Invert  <i>For Pipe Links Only &amp; Upstream Node Initial Stage <math>\neq</math> Downstream Node Initial Stage.</i>	Pipe Link Name Upstream Invert Upstream Initial Stage Downstream Invert Downstream Initial Stage	Reported links should be reviewed. Typically, stormwater models should be initialized with no flow at time zero. Minor initial flows may be acceptable.
5	Initial Flow over Weirs	Review initial flow in weir links. Weir links with potential initial flows are reported.	Upstream Node Initial Stage > Link Upstream Invert Downstream Node Initial Stage > Link Downstream Invert  <i>For Weir Links Only &amp; Upstream Node Initial Stage <math>\neq</math> Downstream Node Initial Stage.</i>	Weir Link Name  To Node Weir Invert Upstream Initial Stage Downstream Initial Stage	Reported links should be reviewed. Typically, stormwater models should be initialized with no flow at time zero. Minor initial flows may be acceptable.
6	Overland Weirs Bypassing Pipes	Review potential inappropriate connectivity. Overland weir links that initiate flow before full pipe flow are reported.	Weir Link Invert < (Pipe Link Invert + Height of Pipe)  <i>For Weir and Pipe Links that share node connectivity &amp; Weir Discharge Coefficient &lt; 3.</i>	Weir Link Name Weir Invert Weir Discharge Coefficient Pipe Link Name Top of Pipe Elevation <sup>2</sup>	Reported links should be reviewed and will likely warrant updates. Typically, pipe crown elevations are below overland flow elevations. This is particularly true in highly urbanized areas. Pipe crown elevations may be below overland flow elevations in less developed areas, but this scenario is rare. More likely, modeled pipe crown elevations above overland flow elevations are an artifact of inaccurate parameterization and/or connectivity.
7	Overland Weirs Bypassing Drop Structures	Review potential inappropriate connectivity. Overland weir links that initiate flow before full drop structure flow are reported.	Weir Link Invert < Drop Structure Weir Invert  <i>For Weir and Drop Structure Links that share node connectivity &amp; Weir Discharge Coefficient &lt; 3.</i>	Weir Link Name Weir Invert Weir Discharge Coefficient  Drop Structure Link Name Drop Structure Weir Name Drop Structure Weir Invert	Reported links should be reviewed and will likely warrant updates. Modeled drop structure weir invert elevations above overland flow elevations are likely an artifact of inaccurate parameterization and/or connectivity.

Report Number	Report Title	Purpose	Input Data Check(s) Performed	Reported Model Data	Recommended Action(s)
8	Suspicious Pipes	Review potential inappropriate parameterization. Pipe links that are assigned parameter values outside typical ranges are reported.	<p>Entrance Loss &gt; 1  Exit Loss &gt; 1  Upstream Manning's n &gt; 0.025  Downstream Manning's n &gt; 0.025  Upstream Depth &gt; 20 feet  Downstream Depth &gt; 20 feet  Upstream Width &gt; 20 feet  Downstream Width &gt; 20 feet  Upstream Manning's n <math>\neq</math> Downstream Manning's n  Upstream Depth <math>\neq</math> Downstream Depth  Upstream Width <math>\neq</math> Downstream Width</p> <p><i>For Pipe Links Only.</i></p>	<p>Pipe Link Name  Entrance Loss Coefficient  Exit Loss Coefficient  Upstream Manning's n  Downstream Manning's n  Upstream Depth  Upstream Width  Downstream Depth  Downstream Width</p>	Reported links should be reviewed. Pipe parameters outside typical ranges will likely warrant revision or further documentation.
9	Pipes with Large Slope	Review potential inappropriate parameterization. Pipe links with significant grade change are reported.	<p>Pipe Slope &gt; 5%</p> <p><i>For Pipe Links Only.</i></p>	<p>Pipe Link Name  Length  Upstream Invert  Downstream Invert <i>Percent Slope</i><sup>3</sup></p>	Reported links should be reviewed.
10	Suspicious Drop Structure Pipes	Review potential inappropriate parameterization. Drop Structure links that are assigned parameter values outside typical ranges for the pipe element are reported.	<p>Entrance Loss &gt; 1  Exit Loss &gt; 1  Upstream Manning's n &gt; 0.025  Downstream Manning's n &gt; 0.025  Upstream Depth &gt; 20 feet  Downstream Depth &gt; 20 feet  Upstream Width &gt; 20 feet  Downstream Width &gt; 20 feet  Upstream Manning's n <math>\neq</math> Downstream Manning's n  Upstream Depth <math>\neq</math> Downstream Depth  Upstream Width <math>\neq</math> Downstream Width  <i>Solution method other than interval halving (i.e., Solution = Combined and Increments = 0)</i></p> <p><i>For Drop Structure Links Only.</i></p>	<p>Drop Structure Link Name  Entrance Loss Coefficient  Exit Loss Coefficient  Upstream Manning's n  Downstream Manning's n  Upstream Depth  Upstream Width  Downstream Depth  Downstream Width  Solution  Increments</p>	Reported links should be reviewed. Pipe parameters outside typical ranges will likely warrant revision or further documentation.

11	Suspicious Drop Structure Weirs	Review potential inappropriate parameterization. Drop Structure links that are assigned parameter values outside typical ranges for the weir element(s) are reported.	Weir Type = Board Crested, Gravel, Paved Vertical Weir Geometry $\neq$ Circular, Horizontal or Vertical Ellipse, Arch, Arch Structural Plate, Rectangular, V-Notch Up Weir Depth > 20 feet Weir Width > 20 feet Weir Discharge Coefficient < 3 Weir Orifice Discharge Coefficient > 0.6	Drop Structure Link Name Drop Structure Weir Name Type Geometry Rise Span Weir Discharge Coefficient Orifice Discharge Coefficient	Reported links should be reviewed. Weir parameters outside typical ranges will likely warrant revision or further documentation.
			<i>For Drop Structure Links Only.</i>		

Report Number	Report Title	Purpose	Input Data Check(s) Performed	Reported Model Data	Recommended Action(s)
12	Drop Weir Invert Low Compared to Pipe Invert	Review potential inappropriate parameterization. Drop Structure links that may induce submerged weir flow are reported.	Drop Structure Weir Invert < (Drop Structure Pipe Invert + Height of Pipe)  <i>For Drop Structure Links Only.</i>	Drop Structure Link Name Drop Structure Weir Name Weir Invert Pipe Invert Pipe Rise <i>Top of Pipe Elevation<sup>2</sup></i>	Reported links should be reviewed. Control structures are typically designed such that flow conveyed through structure openings is realized as unsubmerged weir flow. Some designs such as a low-profile wall in front of the pipe entrance are appropriately modeled as a drop structure link with weir invert(s) below crown of pipe.
13	Suspicious Structural Weirs	Review potential inappropriate parameterization. Weir links that are assigned parameter values outside typical ranges are reported.	Weir Width > 25 feet and Weir Discharge Coefficient > 3 Weir Discharge Coeff > 3 and Weir Orifice Discharge Coefficient < 0.6  <i>For Weir Links Only. All Types.</i>  Weir Discharge Coefficient > 3  <i>For Weir Links Type Board Crested, Gravel, and Paved Vertical Weir Only.</i>	Weir Link Name Span Weir Discharge Coefficient Orifice Discharge Coefficient	Reported links should be reviewed. Weir parameters outside typical ranges will likely warrant revision or further documentation.

- Notes:
1. Percent Difference is calculated by the Tool but is a direct product of model input data. The values are calculated as (Max Node Area – Basin Area) / Max Node Area.
  2. Top of Pipe Elevation is calculated by the Tool but is a direct product of model input data. The values are calculated as Pipe Invert + Pipe Rise.
  3. Percent Slope is calculated by the Tool but is a direct product of model input data. The values are calculated as (Upstream Invert – Downstream Invert) / Length \* 100.



**Attachment 14**

**Outline of Sarasota County ICPR3 to  
ICPR4 Conversion Requirements**



## **Sarasota County ICPR Version 3 to ICPR Version 4 Model Conversion Process**

October 1, 2019

### ***Task 1 – ICPR Version 4 Model Conversion***

Convert the County model and database from the County FTP site from ICPR Version 3 to ICPR Version 4. The Engineer will convert the database to the SWFWMD GWIS v2.1 which is the latest GWIS database compatible with ICPR Version 4 data. This includes the conversion and review of significant number of bridges within the model as version 4 does not allow bridges explicitly in the model. This model will be used to simulate the 100-year storm event. Differences between the Version 3 model and Version 4 model will be documented along with a description of how the differences are reconciled in a summary report. Quality assurance and quality control will be conducted. Engineer will review and document variations of the modeling data and will meet with the County to discuss the variations, as needed. Peak stages and flows, mass balance and model stability will be reviewed between the current model and the converted model. All discrepancies shall be provided to the County, both in tabular format as well as in a GIS shapefile; Engineer will work with the County to develop agreed upon changes (if any) to the peak stages and flows.

### ***Task 2 – Model Verification***

The Engineer will verify the ICPR Version 4 model by reviewing the model results, stability and other available data within the model update areas. The model should be verified to one historic storm as further justification that changes in model results due to conversion still provide a valid model. Quality assurance and quality control will be conducted. The calibration will involve an iterative process of comparing simulated stages, flows and/or volumes with observed data for recent and significant storm events. Engineer will use ARMS data to create storm specific hydrographs and compare the results with ARMS stage data and/or County surveyed high water marks. Up to three (3) storm events will be modeled within the watershed. Additionally, the Engineer will review past meteorological data to determine whether the watersheds were experiencing unusually wet or dry conditions prior to the specific events. If necessary, Engineer will provide suggested modifications to input parameters such as CN, which will have a direct effect on the runoff amounts and peak stages. If the model results do not reasonably resemble the inundation experienced from the calibration event, some of the more sensitive model input parameters shall be revisited, such as:

- Bridge Modeling
- Additional model refinement (additional nodes, links, cross sections, etc.)
- DCIA/UCIA
- SHWT elevation
- Initial conditions and/or Control elevations along major conveyance systems

***Task 3 – Model Verification Summary Report***

The Engineer will prepare a report summarizing work in tasks 1 and 2. A draft report and model will be submitted to the COUNTY for review. County review comments will be incorporated into a final report and final model.

Deliverables:

- ICPR Version 4 model
- GWIS Database consistent with model
- Draft Verification Report
- Final Verification Report
- Quality assurance and quality control documentation
- Model Certification

