

PLAN

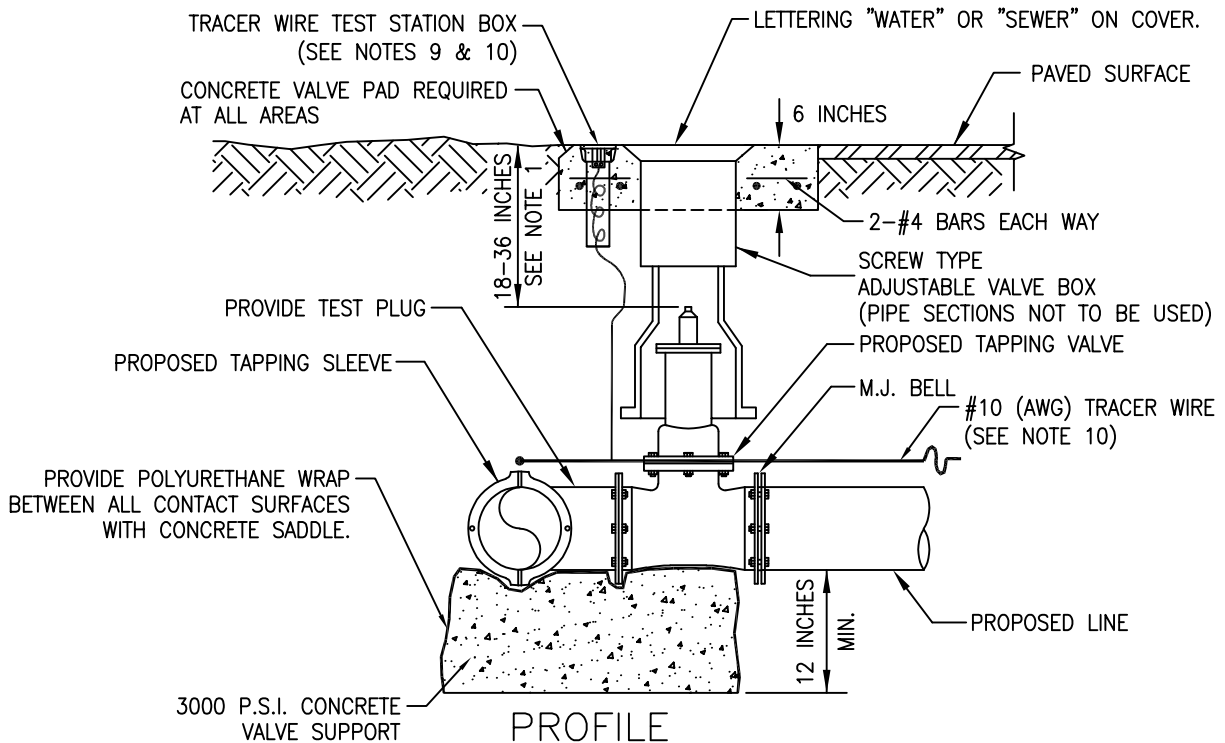

PROFILE

NOTES:

1. VALVE BOX RISER SHALL BE SUPPLIED BY VALVE BOX MANUFACTURER. P.V.C. RISER SHALL NOT BE ALLOWED.
2. NO TAP SHALL BE MADE BEFORE A TEST OF 150 P.S.I. FOR 30 MINUTES IS PERFORMED ON THE VALVE AND SLEEVE ASSEMBLY WITH ZERO LOSS, WITH THE VALVE IN THE OPEN POSITION AND PLUGGED OR CAPPED.
3. PROVIDE CONCRETE VALVE PAD PER GEN. DWG. NO. 1.
4. "W" OR "S" TO BE IMPRESSED INTO THE NEWLY-POURED CONCRETE CURB.
5. ALL EXISTING AND PROPOSED VALVE BOXES SHALL BE ADJUSTED TO FINISHED GRADES AS DETERMINED IN THE FIELD.
6. ALL VALVES SHALL NOT BE PLACED IN HANDICAPPED RAMPS, SIDEWALK, OR CURBS.
7. PRECAST CONCRETE PADS & THRUST BLOCKS SHALL NOT BE USED.
8. ALL EXPOSED EDGE OF CONCRETE SHALL BE CHAMFERED 1 INCH IN UNPAVED AREAS.
9. BINGHAM & TAYLOR P200NFG FOR NORMAL YARD SERVICE. WHERE VALVE WILL BE IN STREET OR PARKING UNDER VEHICLE TRAFFIC, USE P525RD CENTERED IN SEPARATE CONCRETE PAD SIMILAR TO STANDARD VALVE BOX PAD.
10. TRACER WIRE TEST STATION BOX IS NOT REQUIRED IN VALVE BOX PAD IF THE GATE VALVE IS LOCATED WITHIN 200 FEET OF A WATER SERVICE, BLOW-OFF, OR FIRE HYDRANT THAT HAS A TRACER WIRE BOX.
  - a. ALL PIPE SHALL REQUIRE AN INSULATED #10 GAUGE COPPER CLAD STEEL CORE LOCATING WIRE (COPPERHEAD OR APPROVED EQUAL).
  - b. LOCATING WIRES TO TERMINATE 4 INCHES ABOVE CONCRETE VALVE PAD AND FOLDED BACK INSIDE 3 INCH TRACER WIRE STATION BOX.
  - c. LOCATING WIRES SHALL BE CAPABLE OF DETECTION BY A CABLE LOCATOR AND PASS A FIELD CONDUCTIVITY TEST THAT IS WITNESSED BY THE COUNTY FROM END TO END OF WIRES.
  - d. SPLICES SHALL BE CAPABLE OF COMPLETE SUBMERSION. SPLICES SHALL USE DRYCONN OR EQUIVALENT.
  - e. NO MORE THAN ONE SPLICE BETWEEN VALVES IS ALLOWED.

N.T.S.

GENERAL\_DWG\_NO-3.DWG 12/2020



ISSUED NOV. 2023

Revision By Appd. YY.MM.DD

TAPPING SLEEVE & VALVE

GENERAL DWG NO. 3