

ITEM TO BE SUPPLIED BY SARASOTA COUNTY

(AT DEVELOPER'S EXPENSE)

- (A) 2 INCH FLANGED RECLAIM METER LAYING LENGTH = 17 INCHES (WITHOUT GASKETS)
TOTAL LAY LENGTH = 17-1/4 INCHES (WITH GASKETS)

ITEMS TO BE SUPPLIED BY CONTRACTOR

- (B) 2 INCH METER SPUDS
- (C) 2 INCH FLANGED COUPLER ADAPTER KIT
- (D) CONCRETE PAD 4 INCH THICK, MINIMUM 44 INCH x 14 INCH NO REINFORCEMENT WIRE REQUIRED
- (E) 2-1/2 INCH MIP x 2 INCH FIP BUSHING
- (F) 2 INCH x 2 INCH C x FIP ADAPTER
- (G) APPROVED RESILIENT SEAT LOCKABLE BALL VALVE
- (H) HARD COPPER ASSEMBLY
- (J) 6 INCH PHOENIX VALVE BOX (WATER)
- (K) 6 INCH DIA. P.V.C. PIPE
- (L) PVC OR BUTYL INSULATION BETWEEN COPPER PIPE AND CONCRETE PAD
- (M) 4 INCH DIA. BOLLARDS

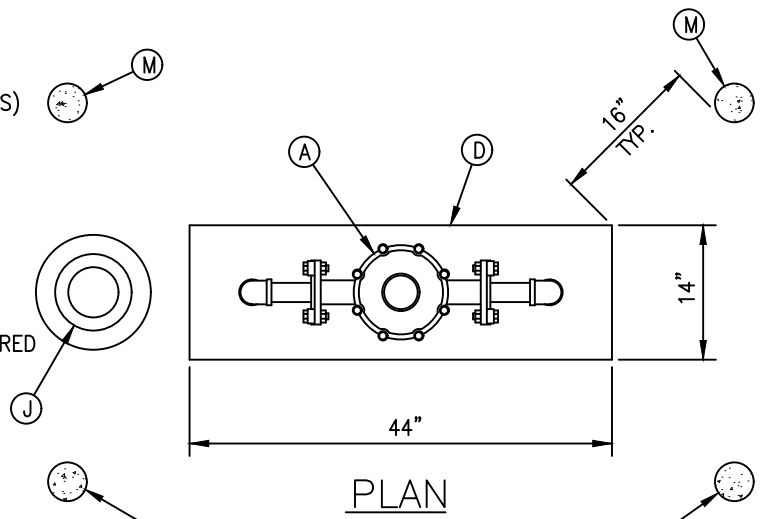

PLAN

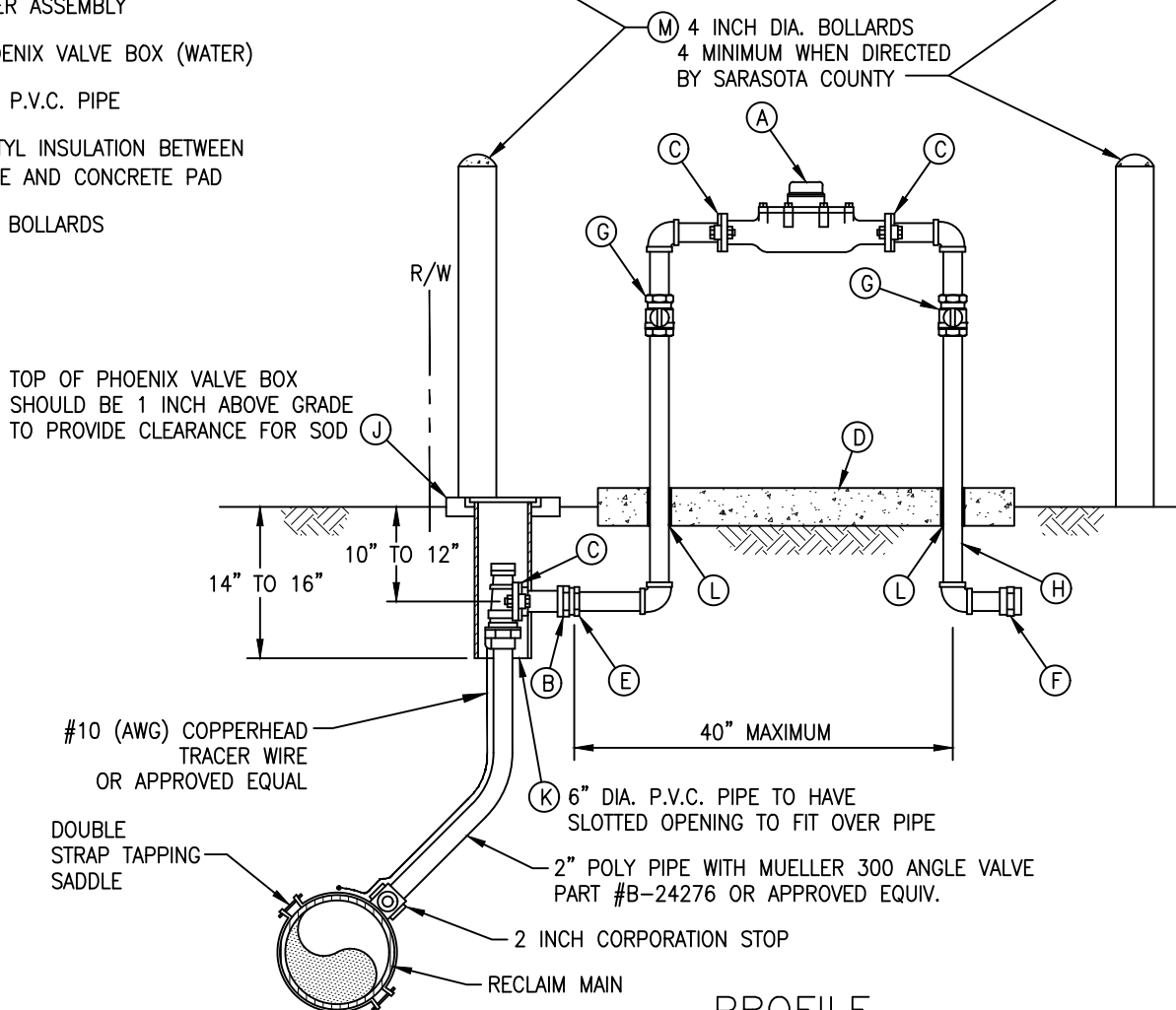

PROFILE

NOTES:

1. PRIMER COAT WITH 2 COATS OF EPOXY FOR ALL ABOVE GROUND APPURTENANCES ABOVE 3 INCHES; FIRE HYDRANTS, METER ASSEMBLIES, VALVES, FORCE MAIN ABOVE GROUND ASSEMBLIES, RECLAIM ASSEMBLIES AND BRIDGE PIPE CROSSINGS.

N.T.S.

RECLAIM_DWG_NO-3.DWG 03/2020