

DOUBLE SWING GATE DETAIL

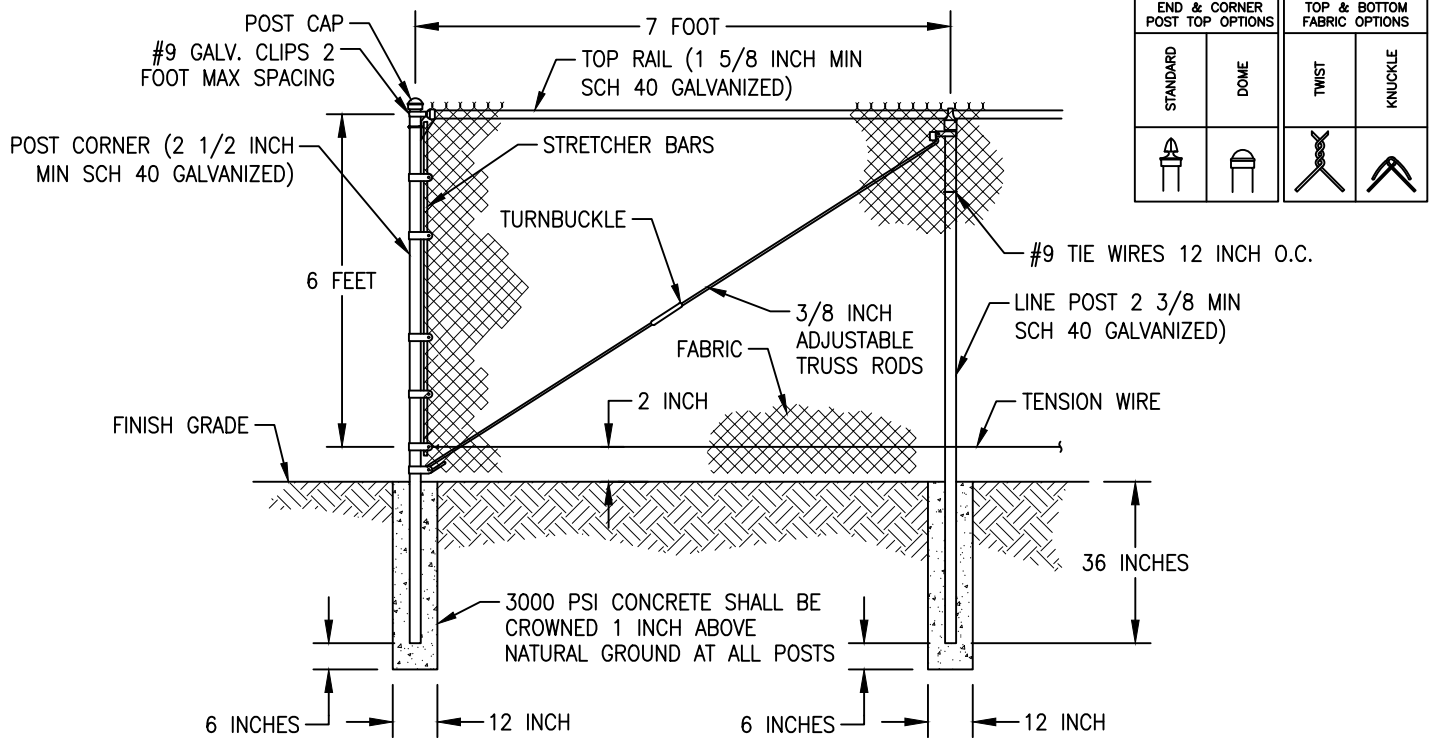

END & CORNER POST TOP OPTIONS		TOP & BOTTOM FABRIC OPTIONS	
STANDARD	DOME	TWIST	KNUCKLE

NOTES:

CHAIN LINK FENCE DETAIL

- FENCING SHALL BE CONCRETE AGGREGATE, STUCCO, BRICK, STONE, SPLIT FACE CONCRETE MASONRY, OR CHAIN LINK.
- CHAIN LINK FENCING SHALL BE #9 GAUGE, GALVANIZED STEEL WITH VINYL COATING.
- TRUSS BARS ON CHAIN LINK FENCES ARE REQUIRED FOR THE FIRST SPAN ON EACH SIDE OF THE CORNER POST AND FOR EACH GATE SECTION.
- LANDSCAPE SCREENING SHALL BE LOCATED ON THE EXTERIOR OF LIFT STATION FENCING.
- SWING GATES SHALL BE CAPABLE OF SWINGING BOTH INWARDS AND OUTWARDS. CANTILEVER SLIDE GATES AND ROLL SLIDE GATES MEETING FDOT DESIGN STANDARDS MAY BE USED AS AN OPTION TO SWING GATES.
- GATE POSTS AND TRACK LINE POSTS SHALL BE 4 INCH SCHEDULE 40 FOR CANTILEVER SLIDE GATES AND ROLL SLIDE GATES.
- GATE TO BE SECURED WITH DROP BAR WITH PADLOCK AND HASP. DROP BAR TO FIT 1 INCH SCH 40 GSP IN 12 INCH DIAMETER x 18 INCH DEEP CONCRETE FOOTING. GATE TO BE SECURED BOTH OPEN AND CLOSED BY TWO GATE STOPS SET IN CONCRETE.
- FENCE SHALL BE DESIGNED TO WITHSTAND 130 MPH WIND LOAD.
- LATCH HARDWARE SHALL BE AMERISTAR STYLE OR EQUAL.
- CONTRACTOR TO HAND DIG IF UTILITIES ARE OR MAY BE IN CONFLICT WITH POSTS.

N.T.S.