

WET WELL

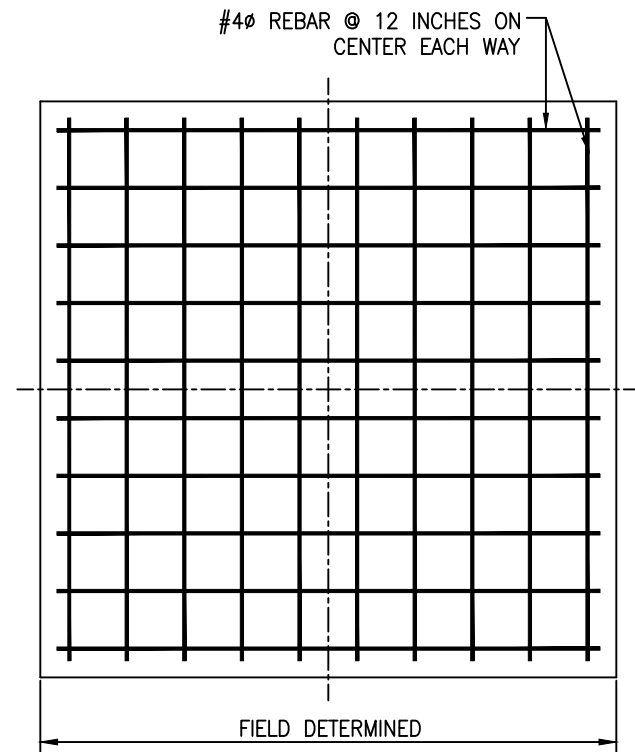

VALVE PAD

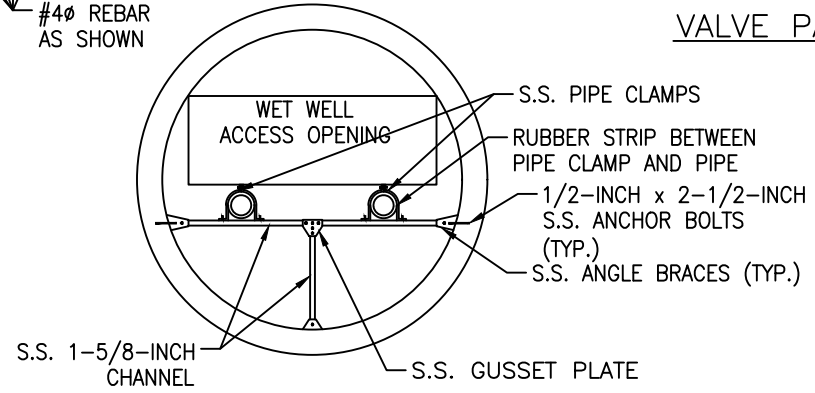

WET WELL PIPE BRACING DETAIL

NOTES:

1. ALL STEEL 3-INCH CLEAR OF ANY EXPOSED SURFACE.
2. 1-INCH CHAMFER ON ALL EXPOSED EDGES.
3. HATCH COVER TO BE CENTERED OVER THE PUMPS AS RECOMMENDED BY PUMP MANUFACTURER.
4. CONTRACTOR TO SET PUMPS AND ACCESS COVER TO ENSURE ACCURATE ALIGNMENT OF GUIDE RAILS AND TO ENSURE PUMP REMOVAL.
5. LIFT STATION WET WELL SHALL BE MANUFACTURED WITH AN APPROVED LINER (SEE ITEM 1 ON SEWER DWG NO. 14).

N.T.S.

SEWER\_DWG\_NO-16.DWG 02/10/2020